

RESOLUTION NO. 2011-546

Adopted by the Sacramento City Council

October 4, 2011

AUTHORIZING A CONSTRUCTION CONTRACT FOR 2011 SPEED HUMP PROJECT (S15101200)

BACKGROUND

- A. The City Speed Hump Program identifies the locations for new speed humps, speed lumps, and speed tables to be constructed throughout the City. The 2011 Speed Hump Project will construct speed lumps and speed tables on the streets shown in Exhibit A.
- B. The project was advertised, bids were received and opened on August 17, 2011. RML Paving is the lowest responsive and responsible bidder at \$167,632 and they have an ESBE participation rate of 100%.
- C. The engineer's estimated construction cost was \$178,891.

BASED ON THE FACTS SET FORTH IN THE BACKGROUND, THE CITY COUNCIL RESOLVES AS FOLLOWS:

- Section 1. The contract specifications for 2011 Speed Hump Project (S15101200) are approved.
- Section 2. The contract for the 2011 Speed Hump Project and for speed lumps on the following Neighborhood Traffic Management Program (S15071100, S15101100) projects: Camellia NTMP, Willow Ranch NTMP, Vista NTMP, Village Park NTMP, Ben Ali NTMP, and Meadows NTMP is awarded to RML Paving for an amount not to exceed \$167,632.
- Section 3. The City Manager is authorized to execute the contract with RML Paving in the amount of \$167,632 for the 2011 Speed Hump Project and for speed lumps on the following Neighborhood Traffic Management Program (S15071100, S15101100) projects: Camellia NTMP, Willow Ranch NTMP, Vista NTMP, Village Park NTMP, Ben Ali NTMP, and Meadows NTMP.
- Section 4. Exhibit A is incorporated into and made part of this Resolution.

Table of Contents:

Exhibit A: Location List of 2011 Speed Hump Project (S15101200)

Adopted by the City of Sacramento City Council on October 4, 2011 by the following vote:

Ayes: Councilmembers D Fong, R Fong, Pannell, Schenirer, Sheedy.

Noes: None.

Abstain: None.

Absent: Councilmembers Ashby, Cohn, McCarty and Mayor Johnson.

Bonnie Pannell, Vice-Mayor

Attest:



Shirley Concolino, City Clerk

EXHIBIT A

Location	Between These Streets	Lumps	Width
17th Street	Wakefield Wy/65th Av	2	35
19th Street	Matson Dr/Kirk Wy	2	25
21st Street	Matson Dr/Meadowview Rd	3	35
36th Street	Y St/2nd Av	2	39
53rd Avenue	City-County Line/Briggs Dr	2	42
53rd Avenue	City-County Line/Briggs Dr	1	34
Addison Way	Casa Linda Dr/Meadowview Rd	2	26
Airport Road	Tanzanite Av/San Juan Rd	2	22
Albatross Way	Marconi Cir/Iris Av	2	21
Albatross Way	Iris Av/Helena Av	1	19
Arcade Boulevard	Fairfield St/Altos Av	2	26
Banfield Drive	Burberry Wy/Club Center Dr	2	35
Burberry Way	Mabry Dr/Birk Wy	2	25
Burberry Way	Dunlay Dr/Banfield Dr	2	25
Casa Linda Drive	Addison Wy/24th St	1	33
Collingwood Street	Matson Dr/Meadowview Rd	3	36
Cromwell Way	Wakefield Wy/West elbow	1	25
Crosby Way	Helena Av/Glenrose Av	1	21
Crosby Way	Glenrose Av/Frienza Av	1	20
Dunlay Drive	Northborough Dr/Mabry Dr	3	25
Dunlay Drive	Mabry Dr/Burberry Wy	2	25
Dunlay Drive	Burberry Wy/Club Center Dr	2	25
Florin Frontage Road	Amherst St/17th St	2	18
Florin Frontage Road	17th St/Cromwell Wy	2	18
Florin Frontage Road	Cromwell Wy/21 St	2	18
Flowerwood Way	N. Elbow/Windbridge Dr	3	25
Frienza Avenue	Van Ness St/Princeton St	1	26
Glenrose Avenue	Auburn Bl/Crosby Wy	2	21
Glenrose Avenue	Crosby Wy/Plover St	1	21
Greg Thatch Circle	Papasas Wy/Tres Peizas Dr	2	35
Helena Avenue	Auburn Bl/Plover St	1	21
Helena Avenue	Auburn Bl/Plover St	1	32
Helena Avenue	Plover St/Albatross Wy	1	21
Iris Avenue	Plover St/Albatross Wy	1	25
Juliesse Avenue	Albatross Wy/Connie Dr	1	19
Kenmar Road	Barros Dr/Sotnip Rd	5	21
Kirk Way	21st St/Collingwood Wy	2	25
Kirk Way	Collingwood Wy/Tamoshanter Wy	2	25
Lejano Way	Osuna Wy/Azevedo Dr	2	25
Mabry Drive	Northborough Dr/Dunlay Dr	2	41
Mabry Drive	Dunlay Dr/Natomas Bl	3	41
Matson Drive	Tamoshanter Wy/24th St	3	35
Milford Street	Wakefield Wy/65th Av	1	25
Mill Oak Way	Truxel Rd/NE curve	2	25

Mill Oak Way	NE Curve/Pebblewood Dr	2	25
Morell Street	W. El Camino Av/Azusa St	2	25.5
Morell Street	W. El Camino Av/Azusa St	1	30
Muirfield Way	Matson Dr/Tamoshanter Wy	4	35
Northborough Drive	Dunlay Dr/Macon Dr	3	43
Oakhurst Way	Amherst St/63rd Av	1	25
Pebblestone Way	Truxel Rd/Stonecreek Dr	2	25
Plover Street	Auburn Bl/Helena Av	1	21
Plover Street	Auburn Bl/Helena Av	1	29
Plover Street	Helena Av/Glenrose Av	1	21
Princeton Street	Glenrose Av/Frienza Av	1	26
Princeton Street	Frienza Av/El Camino Av	1	26
Shining Star Drive	Crownwest Wy/Mandy Dr	3	35
Shining Star Drive	Crownwest Wy/Meadowview Rd	2	35
Skylake Way	West end/Havenside Dr	2	35
Standrich Street	Gunnison Av/Bell Av	2	35
Vinci Avenue	Acme Av/Dry Creek Rd	3	17
Wakefield Way	Tiverton Av/South elbow	1	25
Wakefield Way	17th-St/Cromwell Wy	2	25
Wakefield Way	Cromwell Wy/East elbow	2	25
Western Avenue	Ford Rd/Olmstead Dr	5	36
Wiese Way	Mendal Wy/Erin Dr	2	25
Wilson Avenue	Northglen St/Northgate Bl	2	26

Location	Between These Streets	Tables	Width
Innovator Drive	Prosper Rd/Endeavor Wy	3	40



DEPARTMENT OF
TRANSPORTATION

CITY OF SACRAMENTO
CALIFORNIA

915 I ST
RM 2000
SACRAMENTO, CA
95814-2702

ENGINEERING SERVICES
DIVISION

PH 916-808-8300
FAX 916-808-8281

**CONTRACT SPECIFICATIONS
FOR**

2011 Speed Humps Project

(PN: S15101200)

Non-Refundable Fee
\$ 25.00

Separate Plans

For Pre-Bid Information Call:
Josh Werner, Project Manager
(916) 808-8158

No Pre-bid Meeting scheduled

Bids to be received before
2:00 P.M. August 17, 2011 at:
City Clerk's Office
Historic City Hall
915 I Street, Suite 116
Sacramento, CA 95814

ESBE PROGRAM

For information on meeting the City of Sacramento's Small Business Enterprise (SBE) and Emerging Business Enterprise (EBE) project goals, please contact Noreen James at (916) 808-5470, or visit the City of Sacramento's small business web site at:
http://dev.cityofsacramento.org/econdev/business-open/Sub_small-business-certification.cfm

Estimated Construction Cost: **\$178,891.00** Construction Time: 60 Working Days



DEPARTMENT OF
TRANSPORTATION

CITY OF SACRAMENTO
CALIFORNIA

915 I ST, RM 2000

SACRAMENTO, CA
95814-2702

ENGINEERING SERVICES
DIVISION

PH 916-808-8300
FAX 916-808-8281

July 20, 2011

RE: City of Sacramento Construction Contracting Opportunities

The City of Sacramento is currently soliciting bids **2011 SPEED HUMPS PROJECT (PN: S15101200)** The project will consist of constructing asphaltic concrete speed lumps or speed tables over existing pavement. New signs, sign posts, bollards and striping shall be furnished and installed by the City.

Bids to be received Wednesday, August 17, 2011 at 2:00 p.m. The plans may be reviewed at the following locations:

1. Construction Data & News,
1791 Tribute Rd. Suite D, Sacramento, CA 95815
2. Greater Sacramento Small Business Development Center
1410 Ethan Way, Sacramento, CA 95815
3. Sacramento Builders Exchange
1331 T Street, Sacramento, CA 95814
4. Sacramento Builders Exchange, Roseville Office
1 Sierragate, Suite 290-C, Roseville, CA 95678
5. El Dorado Builders Exchange
3430 Robin Lane, Suite 7, Cameron Park, CA 95682
6. Placer County Builders' Exchange
10656 Industrial Ave, Roseville, CA 95678
7. Construction Market Data
1540 River Park Drive, Suite 117, Sacramento, CA 95815
8. Nevada County Contractors Association
111-A New Mohawk Rd, Nevada City, CA 95959
9. Shasta Builder's Exchange
2990 Innsbruck Dr, Redding, CA 96003
10. San Francisco Builders Exchange
850 South Van Ness Ave, San Francisco, CA 94110-1911
11. Builders Exchange of Santa Clara
400 Reed Street, Santa Clara, CA 95050
12. Sacramento Hispanic Chamber of Commerce
1491 River Park Drive, Ste #101, Sacramento, CA 95815
13. Fresno Builders Exchange
1244 Mariposa Street, Fresno, CA 93707-0111
14. Peninsula Builders Exchange
735 Industrial Rd, Ste #100, San Carlos, CA 94070
15. California Small Business Entrepreneurs, Inc (CalSBE)
3023 East Myrtle Street, Stockton, CA 95205

CONTENTS OF PROJECT MANUAL

	Pages
Invitation to Bid	1 - 4
ESBE Requirements	1 - 3
Apprenticeship Standards	1 - 6
Bid Proposal Form	1 - 3
Bid Proposal Guarantee	1 only
Drug Free Work Place	1 only
Subcontractor Form	1 only
Minimum Qualifications Questionnaire	1 - 6
Non-Discrimination in Employee Benefits Ordinance Certification	1 - 9
Green Contracting Survey	1 - 3
Title VI Language	1 only
City of Sacramento Arizona Policy	1 only
Agreement	1 - 15
Performance Bond	1 only
Payment Bond	1 only
Worker's Compensation Certification	1 only
Construction & Demolition Debris Recycling Requirements	1-6
Pay Request Application	1 only
Schedule of Values	1 only
Guarantee	1 only
Special Provisions	1 - 192

Sealed Proposals will be received by the City Clerk of the City of Sacramento at the office of the City Clerk, Historic City Hall, Ste 116, located at 915 I Street between 9th and 10th Streets, up to the hour of 2:00 PM on **August 17, 2011** and will be opened as soon thereafter as business allows, in the Planning Commission Conference Room, Historic City Hall for:

2011 Speed Humps Project

(PN: S15101200)

as set forth in the Contract Documents.

Proposals received and work performed thereunder shall comply with the requirements of Title 3 of the Sacramento City Code. Each Bid Proposal shall be accompanied by bid security of at least 10% of the sum of the Bid Proposal which conforms to the requirements of Section 7.0 of the Instructions to Bidders. The right to reject Proposals or to waive any error or omission in any Bid Proposal received is reserved by the City. Signed proposals shall be submitted on the printed forms contained in the Project Manual and enclosed in an envelope marked: Sealed Bid Proposal for:

2011 Speed Humps Project

(PN: S15101200)

Copies of the Contract Documents are available at

SIGNATURE REPROGRAPHICS
620 SUNBEAM AVE
SACRAMENTO, CA 95814
916-454-0800

A non-refundable fee of **\$25.00** will be charged.

Subcontractors shall comply with the rates of wages currently established by the Director of Industrial Relations under provisions of Sections 1773 of the Labor Code of the State of California, a copy of which is on file in the office of the City Clerk. In accordance with Sacramento City Code Section 3.60.180 and Section 1771.5 of the California Labor Code, the payment of the general prevailing rate of per diem wages or the general prevailing rate of per diem wages for holiday and overtime is not required for any Public Construction project of \$25,000 or less, or Public Maintenance project of \$15,000 or less. The City of Sacramento has an approved Labor Compliance Program. **Electronic Web submittal of Labor Compliance Reports is effective May 1, 2007.** Each contractor and every lower-tier subcontractor is required to submit certified payrolls and labor compliance documentation electronically at the discretion of and in the manner specified by the City of Sacramento.

Electronic submittal will be a web-based system, accessed on the World Wide Web by a web browser. Each contractor and subcontractor will be given a Log On identification and password to access the City of Sacramento reporting system.

Use of the system may entail additional data entry of weekly payroll information including; employee identification, labor classification, total hours worked and hours worked on this project, wage and benefit rates paid, etc. The contractor's payroll and accounting software might be capable of generating a 'comma delimited file' that will interface with the software.

This requirement will be 'flowed down' to every lower-tier subcontractor and vendor required to provide labor compliance documentation.

ESBE REQUIREMENTS
(City Contracts no Federal Funds Used)

I. **ESBE PROGRAM REQUIREMENTS**

On February 9, 1999, the Sacramento City Council adopted an Emerging and Small Business Development (ESBD) program to provide enhanced opportunities for the participation of small business enterprises (SBEs) and emerging business enterprises (EBEs) in the City's contracting and procurement activities. The ESBD program establishes an annual emerging and small business enterprise (ESBE) participation goal for the City's contracts, and authorizes City departments to require minimum ESBE participation levels in individual contracts so that the annual ESBE participation goal can be met. Under City Code Section 3.60.270, when the bid specifications for a City contract establishes a minimum participation level for ESBEs, **no bidder on the contract shall be considered a responsive bidder unless its bid meets the minimum ESBE participation level required by the bid specifications.**

The City has established a minimum 20% participation level for ESBEs on this contract. Pursuant to City Code Section 3.60.270, no bidder on this contract shall be considered a responsive bidder unless its bid meets or exceeds this minimum participation level.

Bidders shall include copies of their Certification as a SBE or EBE and the SBE or EBE Certifications for each subcontractor, trucker, material supplier, or other business entity listed on the forms submitted with the sealed proposal. **Failure to submit the required ESBE information by the close of business two days after bid opening will be grounds for finding the bid non-responsive.**

II. **ESBE CERTIFICATION**

- A. A SBE designated in the bid must be certified as such by the State of California or by the City, as defined herein, prior to the time bids are received.
- B. An EBE designated in the bid must be certified as such by the City, as defined herein, prior to the time bids are received.

III. **DETERMINATION OF ESBE PARTICIPATION LEVEL**

- A. The percent of ESBE participation shall be determined based on the dollar amount of the work to be performed by a certified ESBEs as that dollar amount is specifically stated on the **SUBCONTRACTOR and ESBE PARTICIPATION VERIFICATION FORM (FM 440)** in the bid package, relative to the total dollar amount of the bid, except as provided other wise below.
- B. To receive credit for participation, a ESBE must perform a commercially useful function; i.e., must be responsible for the execution of a distinct element of the work and must carry its responsibility by actually performing, managing, or supervising the work.
- C. Suppliers: Credit for supplies by ESBEs will be 100 percent.
- D. Truckers: Credit for trucking by ESBEs will be 100 percent.

V. DEFINITIONS

A. Emerging Business Enterprise (EBE)

The City shall certify EBEs utilizing the small business certification criteria and standards of the State of California, General Services Department, Office of Small Business Certification and Resources, that were in effect on December 1, 1998, provided that the size standard, industry by industry, shall be set at 50% of the State small business certification criteria and standards that were in effect on December 1, 1998.

B. Small Business Enterprise (SBE)

The City shall certify SBEs utilizing the small business certification criteria and standards of the State of California, General Services Department, Office of Small Business Certification and Resources. The City will also accept State certified SBEs.

C. CONTRACTOR

The individual, partnership, corporation, joint venture or other legal entity entering into a contract with the City of Sacramento.

D. SUBCONTRACTOR

The individual, partnership, corporation, or other legal entity entering into a contract with the prime contractor to perform a portion of the work.

STATE OF CALIFORNIA - DEPARTMENT OF INDUSTRIAL RELATIONS - DIVISION
OF APPRENTICESHIP STANDARDS
EXCERPTS FROM THE CALIFORNIA LABOR CODE RELATING TO
APPRENTICES ON PUBLIC WORKS
CHAPTER 1 OF DIVISION 2
APPRENTICES ON PUBLIC WORKS
(NOTE: **BOLDFACE TYPE DENOTES KEY POINTS.**)

1773.3. An awarding agency whose public works contract falls within the jurisdiction of Section 1777.5 shall, within five days of the award, send a copy of the award to the Division of Apprenticeship Standards. When specifically requested by a local joint apprenticeship committee, the division shall notify the local joint apprenticeship committee regarding all such awards applicable to the joint apprenticeship committee making the request. Within five days of a finding of any discrepancy regarding the ratio of apprentices to journeymen, pursuant to the certified fixed number of apprentices to journeymen, the awarding agency shall notify the Division of Apprenticeship Standards. (Added by Stats. 1978, Ch. 1249)

1776. (a) Each contractor and subcontractor shall keep an accurate payroll record, showing the name, address, social security number, work classification, straight time and overtime hours worked each day and week, and the actual per diem wages paid to each journeyman, apprentice, worker, or other employee employed by him or her in connection with the public work.
- (b) The payroll records enumerated under subdivision (a) shall be certified and shall be available for inspection at all reasonable hours at the principal office of the contractor on the following basis:
- (1) A certified copy of an employee's payroll record shall be made available for inspection or furnished to the employee or his or her authorized representative on request.
 - (2) A certified copy of all payroll records enumerated in subdivision (a) shall be made available for inspection or furnished upon request to a representative of the body awarding the contract, the Division of Labor Standards Enforcement and the Division of Apprenticeship Standards of the Department of Industrial Relations.
 - (3) A certified copy of all payroll records enumerated in subdivision (a) shall be made available upon request by the public for inspection or copies thereof made; provided, however, that a request by the public shall be made through either body awarding the contract, the Division of Apprenticeship Standards, or the Division of Labor Standards Enforcement. If the requested payroll records have not been provided pursuant to paragraph (2), the requesting party shall, prior to being

1777.5. Nothing in this chapter shall prevent the employment of properly registered apprentices upon public works. Every such apprentice shall be paid the standard wage paid to apprentices under the regulations of the craft or trade at which he or she is employed, and shall be employed only at the work of the craft or trade to which he or she is registered.

Only apprentices, as defined in Section 3077, who are in training under apprenticeship standards and written apprentice agreements under Chapter 4 (commencing with Section 3070) of Division 3, are eligible to be employed on public works. The employment and training for each apprentice shall be in accordance with the apprenticeship standards and apprentice agreements under which he or she is training.

When the contractor to whom the contract is awarded by the state or any political subdivision, or any subcontractor under him or her, in performing any of the work under the contract or subcontract, employs workers in any apprenticeable craft or trade, the contractor and subcontractor shall apply to the joint apprenticeship committee administering the apprenticeship standards of the craft or trade in the area of the site of the public work for a certificate approving the contractor or subcontractor under the apprenticeship standards for the employment and training of apprentices in the area or industry affected. However, approval as established by the joint apprenticeship committee or committees shall be subject to the approval of the Administrator of Apprenticeship.

The joint apprenticeship committee or committees, subsequent to approving the subject contractor or subcontractor, shall arrange for the dispatch of apprentices to the contractor or subcontractor in order to comply with this section. Every contractor and subcontractor shall submit contract award information to the applicable joint apprenticeship committee which shall include an estimate of journeyman hours to be performed under the contract, the number of apprentices to be employed, and the approximate dates the apprentices will be employed. There shall be an affirmative duty upon the joint apprenticeship committee or committees administering the apprenticeship standards of the craft or trade in the area of the site of the public work to ensure equal employment and affirmative action in apprenticeship for women and minorities.

Contractors or subcontractors shall not be required to submit individual applications for approval to local joint apprenticeship committees provided they are already covered by the local apprenticeship standards. The ratio of work performed by apprentices to journeymen who shall be employed in the craft or trade on the public work may be the ratio stipulated in the apprenticeship standards under which the joint apprenticeship committee operates, but, except as otherwise provided in this section, in any case shall the ratio be less than one hour of apprentices work for every five hours of labor performed by a journeyman. However, the minimum ratio for the land surveyor classification shall not be less than one apprentice for each five journeymen.

- (c) There is a showing that the apprenticeable craft or trade is replacing at least one-thirtieth of its journeymen annually through apprenticeship training, either on a statewide basis, or on a local basis.
- (d) Assignment of an apprentice to any work performed under a public works contract would create a condition which would jeopardize his or her life or the life, safety, or property of fellow employees or the public at large or if the specific task to which the apprentice is to be assigned is of such a nature that training cannot be provided by a journeyman.

When exemptions are granted to an organization which represents contractors in a specific trade from the 1-to-5 ratio on a local or statewide basis the member contractors will not be required to submit individual applications for approval to local joint apprenticeship committees, if they are already approved by the local apprenticeship standards.

~~A contractor to whom the contract is awarded, or any subcontractor under him or her, who, in performing any of the work under the contract, employees journeymen or apprentices in any apprenticeable craft or trade and who is not contributing to a fund or funds to administer and conduct the apprenticeship program in any craft or trade in the area of the site of the public work, to which fund or funds other contractors in the area of the site of the public work are contributing, shall contribute to the fund or funds in each craft or trade in which he or she employs journeymen or apprentices on the public work in the same amount or upon the same basis and in the same manner as the other contractors do, but where the trust fund administrators are able to accept the funds, contractors not signatory to the trust agreement shall pay a like amount to the California Apprenticeship Council. The contractor or subcontractor may add the amount of the contributions in computing his or her bid for the contract. The Division of Labor Standards Enforcement is authorized to enforce the payment of the contributions to the fund or funds as set forth in Section 227.~~

The body awarding the contract shall cause to be inserted in the contract stipulations to effectuate this section. The stipulations shall fix the responsibility of compliance with this section for all apprenticeable occupations with the prime contractor.

All decisions of the joint apprenticeship committee under this section are subject to Section 3081.

(Amended by Stats. 1989, Ch. 1224)

1777.6. It shall be unlawful for an employer or a labor union to refuse to accept otherwise qualified employees as registered apprentices on any public works, on the ground of the race, religious creed, color, national origin, ancestry, sex, or age, excepted as provided in Section 3077, of such employee. (Amended by Stats. 1976, Ch. 1179)

BID PROPOSAL FORMS

PLEASE REMOVE AND

COMPLETE

THE FOLLOWING DOCUMENTS

AND

SUBMIT AS

THE BID PROPOSAL

PACKAGE

RML Paving

BID PROPOSAL CHECKLIST

The following items are required to be submitted as part of the bid proposal. Failure to do so will result in the bid being declared not responsive.

<u>Included</u> <u>Please (✓)</u>	<u>Pages</u>
<input checked="" type="checkbox"/> Bid Proposal Form	1-3
<input checked="" type="checkbox"/> Bid Proposal Guarantee	1 only
<input checked="" type="checkbox"/> Drug Free Work Place Certification	1 only
<input checked="" type="checkbox"/> Minimum Qualifications Questionnaire	1 - 6
<input checked="" type="checkbox"/> E/SBE Subcontractor Form*	1 only
<input checked="" type="checkbox"/> Non-Discrimination in Employee Benefits Ordinance Certification	1 - 9
<input checked="" type="checkbox"/> City of Sacramento Arizona Policy	1 page

- *Documentation of subcontractor E/SBE certification is due by no later than close of business two (2) working days after bid opening. Subcontractor list is due with submission of bid. This information is due to Dept of Transportation, Attn: Jose R. Ledesma, 915 I Street, Room 2000, Sacramento CA 95814. Email: jledesma@cityofsacramento.org or fax: 916-808-8281.

CITY OF SACRAMENTO
Department of Transportation
Engineering Services Division

Bid Proposal
Page 1 of 3

TO THE HONORABLE CITY COUNCIL
SACRAMENTO, CALIFORNIA:

In compliance with the Contract Documents, the undersigned hereby proposes to furnish all required labor, materials, supervision, transportation, equipment, services, taxes and incidentals required for:

2011 SPEED HUMP PROJECT (PN: S15101200)

in the City and County of Sacramento, California.

The Work is to be done in strict conformity with the Contract Documents now on file in the Office of the City Clerk, for the following sum:

Item No.	Item	Estimated Quantity	Unit	Unit Price	Total
1	ASPHALTIC CONCRETE SPEED LUMP TO CONSTRUCT	3653	LF (F)	\$ 43,65.	\$ 159453.45
2	ASPHALTIC CONCRETE SPEED TABLE TO CONSTRUCT	120	LF (F)	\$ 68,15	\$ 8178.00

(F) – denotes final pay quantity

CONTRACTOR NAME: AML Paving TOTAL 167631.45
\$ 167631.45

It is understood that this Bid Proposal is based upon completion of the Work within a period of [60] WORKING DAYS, commencing on the date set forth in the written Notice to Proceed issued by the City to the Contractor.

In determining the amount bid by each bidder, the City may disregard mathematical errors in addition, subtraction, multiplication, and division that appear obvious on the face of the Proposal. When such a mathematical error appears on the face of the Proposal, the City shall have the right to correct such error and to compute the total amount bid by said bidder on the basis of the corrected figure or figures.

The City Council may reject any and all bids and waive any informalities or minor irregularities in the bids.

When an item price is required to be set forth in the Proposal, and the total for the item set forth separately does not agree with a figure which is derived by multiplying the item price times the Engineer's estimate of the quantity of work to be performed for said item, the item price shall prevail over the sum set forth as the total for the item unless, in the sole discretion of the City, such a procedure would be inconsistent with the policy of the bidding procedure. The total paid for each such item of work shall be based upon the item price and not the total price. Should the Proposal contain only total price for the item and the item price is omitted,

CITY OF SACRAMENTO
Department of Transportation
Engineering Services Division

Bid Proposal
Page 2 of 3

the City shall determine the item price by dividing the total price for the item by the Engineer's estimate of the estimated quantities of work to be performed as items of work.

If the Proposal contains neither the item price nor the total price for the item, then it shall be deemed incomplete and the Proposal shall be disregarded.

The undersigned has examined the location of the proposed Work, the local conditions at the place where the Work is to be done, is familiar with the Contract Documents and is familiar and expressly agrees to the liquidated damages provision of the Contract Documents.

The undersigned has checked carefully all of the foregoing figures and understands that the City of Sacramento will not be responsible for any errors or omissions on the part of the undersigned in making up this Bid Proposal.

Enclosed is a Bid Proposal Guarantee, as required, consisting of a bidder's bond or other acceptable security for not less than ten percent (10%) of the amount Bid Proposal.

The undersigned agrees that all addenda received and acknowledged herein shall become a part of and be included in this Bid Proposal. This Bid Proposal includes the following addenda:

Add. #	_____	DATE	_____
Add. #	_____	DATE	_____
Add. #	_____	DATE	_____

NOTE: State whether your concern is a corporation, a co-partnership, private individual, or individuals doing business under a firm name.

If the Bidder is a corporation, the Bid Proposal must be executed in the name of the corporation and must be signed by a duly authorized officer of the corporation.

If the Bidder is a partnership, the Bid Proposal must be executed in the name of the partnership and one of the partners must subscribe their signature thereto as the authorized representative of the partnership.

AMOUNT OF BID PROPOSAL GUARANTEE ENCLOSED:

(\$ _____) not less than ten percent (10%) of amount Bid Proposal

CERTIFIED CHECK
CASHIER'S CHECK
BID BOND ✓
MONEY ORDER
OTHER SECURITY

CONTRACTOR:

By 
(Signature)

Rodolfo Martinez
(Print or Type)

Title owner

Address 7431 Peacock Way

Sacramento CA 95820

Telephone No. 916 215-2070

Fax No. (916) 381-1054

Email Address ronleaving@sbcglobal.net

Date 8/17/11

FOR CITY USE ONLY

Bid Bond Security	
<input type="checkbox"/> Property Signed	<input type="checkbox"/> Improperly Signed
<input type="checkbox"/> Not Included	<input type="checkbox"/> Not Required
Type of Deposit	
<input checked="" type="checkbox"/> Bid Bond	<input type="checkbox"/> Cashier/Certified Check
<input type="checkbox"/> Other	Initial: <u>VE</u>

Contractor's License No. 832381 Type C-12

Expiration Date 02/29/2019

Tax I.D. Nos.- Fed. 51-0524897 State CA

City of Sacramento Business Operation Tax Certificate No. 13641
(City will not award contract if Certificate Number is missing.)

Please indicate if you are any of the following:

EBE _____ Cert # _____

SBE Cert # 44805

UDBE _____ Cert # _____

MWBE _____ Cert # _____

BID BOND

Bond Number: 71150808
Premimu: \$100.00

KNOW ALL MEN BY THESE PRESENTS, that we

Rodolfo Martinez DBA R M L Paving as Principal, and

Western Surety Company a corporation duly

organized under the laws of the State of South Dakota as Surety, are bound unto

City Of Sacramento, as Obligee, in the sum of

10% of Amount Bid Not To Exceed \$17,000.00 (***)

For payment of which sum well and truly to be made, Principal and Surety, bind ourselves, our heirs, executors, administrators, successors, and assigns, jointly and severally, firmly by these presents.

WHEREAS, the Principal has submitted a bid for Multiple Locations Speed Bumps

with a bid date of 08/17/2011

NOW, THEREFORE, if the Obligee shall accept the bid of the Principal and the Principal shall enter into a Contract with the Obligee in accordance with the terms of such bid, and give such bond or bonds as may be specified in the bidding or Contract Documents with good and sufficient surety for the faithful performance of such Contract and for the prompt payment of labor and material furnished by the prosecution thereof, or in the event of failure of the Principal to enter such Contract and give such bond or bonds, if the Principal shall pay to the Obligee the difference not to exceed the penalty hereof between the amount specified in said bid and such larger amount for which the Obligee may in good faith contract with another part to perform the work covered by said bid, then this obligation shall be null and void, otherwise to remain in full force and effect.

Signed and sealed this 8 day of August, 2011

PRINCIPAL:

SURETY:

Rodolfo Martinez DBA R M L Paving

Western Surety Company

By: [Signature]

By: [Signature]

Rodolfo Martinez owner
Name and Title

Barry R. Page, Attorney-in-Fact
Name and Title



Western Surety Company

POWER OF ATTORNEY APPOINTING INDIVIDUAL ATTORNEY-IN-FACT

Know All Men By These Presents, That WESTERN SURETY COMPANY, a South Dakota corporation, is a duly organized and existing corporation having its principal office in the City of Sioux Falls, and State of South Dakota, and that it does by virtue of the signature and seal herein affixed hereby make, constitute and appoint

John T Page, Barry R Page, Amy Elizabeth Johnston, Individually

of Rancho Cordova, CA, its true and lawful Attorney(s)-in-Fact with full power and authority hereby conferred to sign, seal and execute for and on its behalf bonds, undertakings and other obligatory instruments of similar nature

- In Unlimited Amounts -

and to bind it thereby as fully and to the same extent as if such instruments were signed by a duly authorized officer of the corporation and all the acts of said Attorney, pursuant to the authority hereby given, are hereby ratified and confirmed.

This Power of Attorney is made and executed pursuant to and by authority of the By-Law printed on the reverse hereof, duly adopted, as indicated, by the shareholders of the corporation.

In Witness Whereof, WESTERN SURETY COMPANY has caused these presents to be signed by its Senior Vice President and its corporate seal to be hereto affixed on this 28th day of March, 2011.



WESTERN SURETY COMPANY

Paul T. Bruflat

Paul T. Bruflat, Senior Vice President

State of South Dakota }
County of Minnehaha } ss

On this 28th day of March, 2011, before me personally came Paul T. Bruflat, to me known, who, being by me duly sworn, did depose and say: that he resides in the City of Sioux Falls, State of South Dakota; that he is the Senior Vice President of WESTERN SURETY COMPANY described in and which executed the above instrument; that he knows the seal of said corporation; that the seal affixed to the said instrument is such corporate seal; that it was so affixed pursuant to authority given by the Board of Directors of said corporation and that he signed his name thereto pursuant to like authority, and acknowledges same to be the act and deed of said corporation.

My commission expires
November 30, 2012

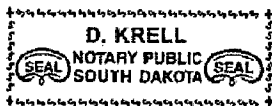

D. Krell

D. Krell, Notary Public

CERTIFICATE

I, L. Nelson, Assistant Secretary of WESTERN SURETY COMPANY do hereby certify that the Power of Attorney hereinabove set forth is still in force, and further certify that the By-Law of the corporation printed on the reverse hereof is still in force. In testimony whereof I have hereunto subscribed my name and affixed the seal of the said corporation this 8 day of August, 2011.

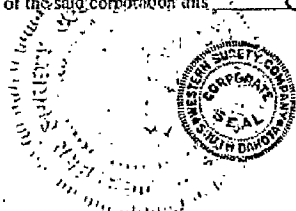

WESTERN SURETY COMPANY

L. Nelson

L. Nelson, Assistant Secretary

Authorizing By-Law

ADOPTED BY THE SHAREHOLDERS OF WESTERN SURETY COMPANY

This Power of Attorney is made and executed pursuant to and by authority of the following By-Law duly adopted by the shareholders of the Company.

Section 7. All bonds, policies, undertakings, Powers of Attorney, or other obligations of the corporation shall be executed in the corporate name of the Company by the President, Secretary, and Assistant Secretary, Treasurer, or any Vice President, or by such other officers as the Board of Directors may authorize. The President, any Vice President, Secretary, any Assistant Secretary, or the Treasurer may appoint Attorneys in Fact or agents who shall have authority to issue bonds, policies, or undertakings in the name of the Company. The corporate seal is not necessary for the validity of any bonds, policies, undertakings, Powers of Attorney or other obligations of the corporation. The signature of any such officer and the corporate seal may be printed by facsimile.

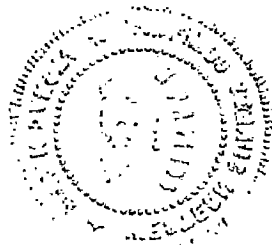

ACKNOWLEDGMENT

State of California
County of Sacramento

On 8/8/2011 before me, Erin Tumacder, Notary Public
(Insert name and title of the officer)

personally appeared Barry R. Page
who proved to me on the basis of satisfactory evidence to be the person(s) whose name(s) is/are
subscribed to the within instrument and acknowledged to me that he/she/they executed the same in
his/her/their authorized capacity(ies), and that by his/her/their signature(s) on the instrument the
person(s), or the entity upon behalf of which the person(s) acted, executed the instrument.

I certify under PENALTY OF PERJURY under the laws of the State of California that the foregoing
paragraph is true and correct.

WITNESS my hand and official seal.

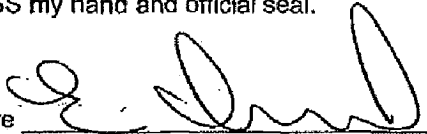
Signature  (Seal)

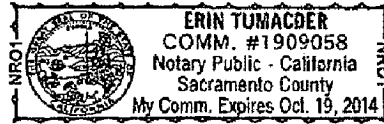

DRUG-FREE WORKPLACE POLICY AND AFFIDAVIT

BID PROPOSAL MAY BE DECLARED NONRESPONSIVE IF THIS FORM (COMPLETED) IS NOT ATTACHED.
Pursuant to City Council Resolution CC90-498 dated 6/26/90 the following is required.

The undersigned contractor certifies that it and all subcontractors performing under this Agreement will provide a drug-free workplace by:

1. Publishing a "Drug-Free Workplace" statement notifying employees that the unlawful manufacture, distribution, dispensing, possession or use of a controlled substance is prohibited in the contractor's workplace and specifying the actions that will be taken against employees for violations of such prohibition.
2. Establishing a Drug-Free Awareness Program to inform employees about:
 - a. The dangers of drug abuse in the workplace.
 - b. The contractor's policy of maintaining a drug-free workplace.
 - c. Any available drug counseling, rehabilitation, and employee assistance program.
 - d. The penalties that may be imposed upon employees for drug abuse violations occurring in the workplace.
3. Notify employees that as a condition of employment under this Agreement, employees will be expected to:
 - a. Abide by the terms of the statement.
 - b. Notify the employer of any criminal drug statute conviction for a violation occurring in the workplace.
4. Making it a requirement that each employee to be engaged in the performance of the Agreement be given a copy on the "Drug-Free Workplace" statement.
5. Taking one of the following appropriate actions, within thirty (30) days of receiving notice from an employee or otherwise receiving such notice, that said employee has received a drug conviction for a violation occurring in the workplace:
 - a. Taking appropriate disciplinary action against such an employee, up to and including termination; or
 - b. Requiring such employee to participate satisfactorily in a drug abuse assistance or rehabilitation program approved for such purposes by a federal, state, or local health, law enforcement or other appropriate agency.

* I certify that no person employed by this company, corporation, or business has been convicted of any criminal drug statute violation on any job site or project where this company, corporation or business was performing was within three years of the date of my signature below.

EXCEPTION:

Date	Violation Type	Place of Occurrence
------	----------------	---------------------

If additional space is required use back of this form.

* The above statement will also be incorporated as a part of each subcontract agreement for any and all subcontractors selected for performance on this project.

IN THE EVENT THIS COMPANY, CORPORATION, OR BUSINESS IS AWARDED THIS CONSTRUCTION AGREEMENT, AS A RESULT OF THIS BID; THE CONTRACTOR WITH HIS/HER SIGNATURE REPRESENTS TO THE CITY THAT THE INFORMATION DISCLOSED IN THIS DOCUMENT IS COMPLETE AND ACCURATE. IT IS UNDERSTOOD AND AGREED THAT FALSE CERTIFICATION IS SUBJECT TO IMMEDIATE TERMINATION BY THE CITY.

The Representations Made Herein On This Document Are Made Under Penalty Of Perjury.

CONTRACTOR'S NAME: RM2 Paving
BY: [Signature] Signature owner Title Date: 8/17/2011

Effects of violations: a. Suspension of payments under the Agreement. b. Suspension or termination of the Agreement. c. Suspension or debarment of the contractor from receiving any Agreement from the City of Sacramento for a period not to exceed five years.

CITY OF SACRAMENTO

THIS FORM MUST BE SUBMITTED WITH THE SEALED BID PROPOSAL

CITY OF SACRAMENTO SUBCONTRACTOR and ESBE PARTICIPATION VERIFICATION

To be eligible for award of this contract, the bidder shall list any business entity used to attain the 20% ESBE goal. Additionally, all other subcontractors who perform work, labor, or render service in an amount in excess of one-half of 1 percent of the total bid amount shall be listed. In the case of bids for the construction of streets and highways, including bridges, subcontractors whose subcontract value exceeds one-half (0.5) of one percent of the total bid or ten thousand dollars (\$10,000), whichever is greater, shall be listed. Estimated dollar values shall be provided for all work / services listed. The inclusion of false information or the omission of required information will render the bid non-responsive. **READ THE ABOVE REQUIREMENT CAREFULLY**

Name of Prime Contractor: <i>RML Paving</i>		Bid Amount: <i>1,676,317.15</i>	Date: <i>8/17/11</i>
Business Entity or Subcontractor Name and Location	Indicate EBE or SBE (subject to verification)	Items of Work and/or Description of Work or Service Subcontracted or Materials to be provided to complete contract	Estimated Dollar Value of Work / Services Provided

EBE AND SBE CERTIFICATION STATEMENTS ARE DUE BY THE CLOSE OF BUSINESS TWO DAYS AFTER BID OPENING

MINIMUM QUALIFICATIONS QUESTIONNAIRE

Sacramento City Code Section 3.60.020 authorizes the Sacramento City Council to adopt standard minimum qualifications for bidders on competitively bid public works construction projects, and requires, among other provisions, that a bidder meet such minimum qualifications at the time of bid opening in order to bid. On July 31, 2007, the City Council adopted Resolution No. 2007-574 establishing these standard minimum qualifications. Pursuant to City Code section 3.60.020, a bidder failing to meet these minimum qualifications at the time of bid opening shall not be considered a responsible bidder for purposes of bidding on the subject project.

All bidders must demonstrate compliance with the minimum qualifications established by Resolution No. 2007-574 by completing all of the questions contained in this questionnaire. Bidder responses shall be limited to those operating business units, offices, branches and/or subsidiary divisions of the bidder that will be involved with the performance of any project work if awarded the contract. If a bidder answers "yes" to any single question, fails to submit a fully completed questionnaire, or submits false information, this will result in a determination that the minimum qualifications are not met, and the bidder shall not be considered a qualified bidder for purposes of bidding on this contract. If two or more entities submit a bid on a contract as a Joint Venture, each entity within the Joint Venture must separately meet these minimum qualifications for the Joint Venture to be considered a qualified bidder.

The City of Sacramento ("City") shall make its determination on the basis of the submitted questionnaire, as well as any relevant information that is obtained from others or as a result of investigation by the City. While it is the intent of this questionnaire to assist the City in determining whether bidders possess the minimum qualifications necessary to submit bids on the City's competitively bid public works construction contracts, the fact that a bidder submits a questionnaire demonstrating that it meets these minimum qualifications shall not in any way limit or affect the City's ability to: (1) review other information contained in the bid submitted by the bidder, and additional relevant information, and determine whether the contractor is a responsive and/or responsible bidder; or (2) establish pre-qualification requirements for a specific contract or contracts.

By submitting this questionnaire, the bidder consents to the disclosure of its questionnaire answers: (i) to third parties for purposes of verification and investigation; (ii) in connection with any protest, challenge or appeal of any action taken by the City; and (iii) as required by any law or regulation, including without limitation the California Public Records Act (Calif. Gov't Code sections 6250 et seq.). Each questionnaire must be signed under penalty of perjury in the manner designated at the end of the form, by an individual who has the legal authority to bind the bidder submitting the questionnaire. If any information provided by a bidder becomes inaccurate, the bidder shall immediately notify the City and provide updated accurate information in writing, under penalty of perjury.

FOR CITY CLERK USE ONLY

RESOLUTION NO.: 2007-574

DATE ADOPTED: July 31, 2007

QUESTIONNAIRE

NOTICE: For firms that maintain other operating business units, offices, branches and/or subsidiary divisions that will not be involved with the performance of any project work if the firm is awarded the contract, references hereafter to "your firm" shall mean only those operating business units, offices, branches and/or subsidiary divisions that will be involved with the performance of any project work.

All of the following questions regarding "your firm" refer to the firm (corporation, partnership or sole proprietor) submitting this questionnaire, as well as any firm(s) with which any of your firm's owners, officers, or partners are or have been associated as an owner, officer, partner or similar position within the last five years

The firm submitting this questionnaire shall not be considered a responsible bidder if the answer to any of these questions is "yes", or if the firm submits a questionnaire that is not fully completed or contains false information.

1. Classification & Expiration Date(s) of California Contractor's License Number(s) held by firm:

C-12 2/29/2012 832381

2. Has a contractor's license held by your firm and/or any owner, officer or partner of your firm been revoked at anytime in the last five years?

Yes

No

3. Within the last five years, has a surety firm completed a contract on your firm's behalf, or paid for completion of a contract to which your firm was a party, because your firm was considered to be in default or was terminated for cause by the project owner?

Yes

No

4. At the time of submitting this minimum qualifications questionnaire, is your firm ineligible to bid on or be awarded a public works contract, or perform as a subcontractor on a public works contract, pursuant to either California Labor Code section 1777.1 (prevailing wage violations) or Labor Code section 1777.7 (apprenticeship violations)?

Yes

No

5. At any time during the last five years, has your firm, or any of its owners, officers or partners been convicted of a crime involving the awarding of a contract for a government construction project, or the bidding or performance of a government contract?

Yes

No

FOR CITY CLERK USE ONLY

RESOLUTION NO.: 2007-574

DATE ADOPTED: July 31, 2007

6. Answer either subsection A or B, as applicable:

A. Your firm has completed three or more government construction contracts in Sacramento County within the last five years: Within those five years, has your firm been assessed liquidated damages on three or more government construction contracts in Sacramento County for failure to complete contract work on time?

NOTE: If there is a pending administrative or court action challenging the assessment of liquidated damages on a government contract within the last five years, you need not include that contract in responding to this question.

Yes No Not applicable

OR

B. Your firm has not completed at least three government construction contracts in Sacramento County within the last five years: Within the last three years, has your firm been assessed liquidated damages on three or more government construction contracts for failure to complete contract work on time?

NOTE: If there is a pending administrative or court action challenging an assessment of liquidated damages on a government contract within the last three years, you need not include that contract in responding to this question.

Yes No Not applicable

7. In the last three years has your firm been debarred from bidding on, or completing, any government agency or public works construction contract for any reason?

NOTE: If there is a pending administrative or court action challenging a debarment, you need not include that debarment in responding to this question.

Yes No

8. Has CAL OSHA assessed a total of three or more penalties against your firm for any "serious" or "willful" violation occurring on construction projects performed in Sacramento County at any time within the last three years?

NOTE: If there is a pending administrative or court action appealing a penalty assessment, you need not include that penalty assessment in responding to this question.

Yes No

FOR CITY CLERK USE ONLY

RESOLUTION NO.: 2007-574

DATE ADOPTED: July 31, 2007

9. Answer either subsection A or B, as preferred:

A. In the last three years has your firm had a three year average Workers' Compensation experience modification rate exceeding 1.1?

Yes

No

OR

B. In the last three years has your firm had a three-year average incident rate for total lost workday cases exceeding 10?

NOTE: Incident rates represent the number of lost workday cases per 100 full-time workers and is to be calculated as: $(N/EH) \times 200,000$, where

N = number of lost workday cases (as defined by the U.S. Dept. of Labor, Bureau of Labor Statistics)
EH = total hours worked by all employees during the calendar year
200,000 = base for 100 equivalent full-time working (working 40 hours per week, 50 weeks per year)

Yes

No

10. In the past three years, has the federal EPA, Region IX or a California Air Quality Management District or Regional Water Quality Control Board assessed penalties three or more times, either against your firm, or against the project owner for a violation resulting in whole or in part from any action or omission by your firm on a project on which your firm was a contractor in Sacramento County?

NOTE: If there is a pending administrative or court action appealing a penalty assessment, you need not include that penalty assessment in responding to this question.

Yes

No

FOR CITY CLERK USE ONLY

RESOLUTION NO.: 2007-574

DATE ADOPTED: July 31, 2007

11. In the past three years, has the federal EPA, Region IX or a California Air Quality Management District or Regional Water Quality Control Board assessed a single penalty of \$100,000 or more, either against your firm, or against the project owner for a violation resulting in whole or in part from any action or omission by your firm on a project on which your firm was the contractor in Sacramento County?

NOTE: If there is a pending administrative or court action appealing a penalty assessment, you need not include that penalty assessment in responding to this question.

Yes

No

12. In the past three years, have civil penalties been assessed against your firm pursuant to California Labor Code 1777.7 for violation of California public works apprenticeship requirements, three or more times?

NOTE: If there is a pending administrative or court action appealing a penalty assessment, you need not include that penalty assessment in responding to this question.

Yes

No

13. In the past three years, has a public agency in California withheld contract payments or assessed penalties against your firm for violation of public works prevailing wage requirements, three or more times?

NOTE: If there is a pending administrative or court action appealing a withholding or penalty assessment, you need not include that withholding or penalty assessment in responding to this question.

Yes

No

14. Has your firm been assessed penalties for violation of public works prevailing wage requirements in California, in an aggregate amount for the past three years of \$50,000 or more?

NOTE: If there is a pending administrative or court action appealing a penalty assessment, you need not include that penalty assessment in responding to this question.

Yes

No

FOR CITY CLERK USE ONLY

RESOLUTION NO.: 2007-574

DATE ADOPTED: July 31, 2007

VERIFICATION AND SIGNATURE

I, the undersigned, certify and declare that I have read all the foregoing answers to this Minimum Qualifications Questionnaire, and know their contents. The matters stated in these Questionnaire answers are true of my own knowledge and belief, except as to those matters stated on information and belief, and as to those matters I believe them to be true. I declare under penalty of perjury under the laws of the State of California that the foregoing is true and correct.

Signed at Sacramento (Location), on 8/17/11 (Date).

Signature: 

Print name: Rodolfo Martinez

Title: owner

NOTE: If two or more entities submit a bid on a contract as a Joint Venture, each entity within the Joint Venture must submit a separate Minimum Qualifications Questionnaire.

FOR CITY CLERK USE ONLY

RESOLUTION NO.: 2007-574

NON-DISCRIMINATION IN EMPLOYEE BENEFITS BY CITY CONTRACTORS ORDINANCE

INTRODUCTION

The Sacramento Non-Discrimination In Employee Benefits By City Contractors Ordinance (the "Ordinance"), codified as Sacramento City Code Chapter 3.54, prohibits City contractors from discriminating in the provision of employee benefits between employees with spouses and employees with domestic partners, and between the spouses and domestic partners of employees.

APPLICATION

The provisions of the Ordinance apply to any contract or agreement (as defined below), between a Contractor and the City of Sacramento, in an amount exceeding \$25,000.00. The Ordinance applies to that portion of a contractor's operations that occur: (i) within the City of Sacramento; (ii) on real property outside the City of Sacramento if the property is owned by the City or if the City has a right to occupy the property; or (iii) at any location where a significant amount of work related to a City contract is being performed. The provisions apply only to those employee(s) actually working on the City contract and only for the actual amount of time the employee(s) spend working on such contract.

The Ordinance does not apply: to subcontractors or subcontracts of any Contractor or contractors; to transactions entered into pursuant to cooperative purchasing agreements approved by the Sacramento City Council; to legal contracts of other governmental jurisdictions or public agencies without separate competitive bidding by the City; where the requirements of the ordinance will violate or are inconsistent with the terms or conditions of a grant, subvention or agreement with a public agency or the instructions of an authorized representative of any such agency with respect to any such grant, subvention or agreement; to contracts for excavation or street construction; or to agreements for the use of City right-of-way where a contracting utility has the power of eminent domain.

DEFINITIONS

As set forth in the Ordinance, the following definitions apply:

"Contract" means an agreement for public works or improvements to be performed, or for goods or services to be purchased or grants to be provided, at the expense of the City or to be paid out of moneys deposited in the treasury or out of the trust money under the control or collected by the City. "Contract" also means a written agreement for the exclusive use ("exclusive use" means the right to use or occupy real property to the exclusion of others, other than the right reserved by the fee owner) or occupancy of real property for a term exceeding 29 days in any calendar year, whether by singular or cumulative instrument, (i) for the operation or use by others of real property owned or controlled by the City for the operation of a business, social, or other establishment or organization, including leases, concessions, franchises and easements, or (ii) for the City's use of occupancy of real property owned by others, including leases, concessions, franchises and easements.

"Contract" shall not include: a revocable at-will use or encroachment permit for the use of or encroachment on City property regardless of the ultimate duration of such permit; excavation, street construction or street use permits; agreements for the use of City

NON-DISCRIMINATION IN EMPLOYEE BENEFITS BY CITY CONTRACTORS ORDINANCE

right-of-way where a contracting utility has the power of eminent domain; or agreements governing the use of City property that constitute a public forum for activities that are primarily for the purpose of espousing or advocating causes or ideas and that are generally protected by the First Amendment to the United States Constitution or that are primarily recreational in nature.

"Contractor" means any person or persons, firm partnership or corporation, company, or combination thereof, that enters into a Contract with the City. "Contractor" does not include a public entity.

"Domestic Partner" means any person who has a currently registered domestic partnership with a governmental entity pursuant to state or local law authorizing the registration.

"Employee Benefits" means bereavement leave; disability, life, and other types of insurance; family medical leave; health benefits; membership or membership discounts; moving expenses; pension and retirement benefits; vacation; travel benefits; and any other benefit given to employees; "Employee benefits" shall not include benefits to the extent that the application of the requirements of this chapter to such benefits may be preempted by federal or state.

CONTRACTOR'S OBLIGATION TO PROVIDE THE CITY WITH DOCUMENTATION AND INFORMATION

Contractor shall provide the City with documentation and information verifying its compliance with the requirements of the Ordinance within ten (10) days of receipt of a request from the City. Contractors shall keep accurate payroll records, showing, for each City Contract, the employee's name, address, Social Security number, work classification, straight time pay rate, overtime pay rate, overtime hours worked, status and exemptions, and benefits for each day and pay period that the employee works on the City Contract. Each request for payroll records shall be accompanied by an affidavit to be completed and returned by the Contractor, as stated, attesting that the information contained in the payroll records is true and correct, and that the Contractor has complied with the requirements of the Ordinance. A violation of the Ordinance or noncompliance with the requirements of the Ordinance shall constitute a breach of contract.

EMPLOYER COMPLIANCE CERTIFICATE AND NOTICE REQUIREMENTS

(a) All contractors seeking a Contract subject to the Ordinance shall submit a completed Declaration of Compliance Form (attachment "A"), signed by an authorized representative, with each proposal, bid or application. The Declaration of Compliance shall be made a part of the executed contract, and will be made available for public inspection and copying during regular business hours.

(b) The Contractor shall give each existing employee working directing on a City contract, and (at the time of hire), each new employee, a copy of the notification provided as attachment "B."

(c) Contractor shall post, in a place visible to all employees, a copy of the notice provided as attachment "C."

**NON-DISCRIMINATION IN EMPLOYEE BENEFITS BY CITY CONTRACTORS
ORDINANCE**

**DECLARATION OF COMPLIANCE
Equal Benefits Ordinance**

R.M.L. Paving
Name of Contractor

7431 Peacock way Sacramento CA 95820
Address

The above named contractor ("Contractor") hereby declares and agrees as follows:

1. I have read and understand the Non-Discrimination In Employee Benefits By City Contractors Ordinance ("Ordinance") provided to me by the City of Sacramento ("City") in connection with the City's request for proposals or other solicitations for the performance of services, or for the provision of commodities, under a City contract or agreement ("Contract").
2. As a condition of receiving the City Contract, I agree to fully comply with the requirements of the Ordinance, codified as Chapter 3. 54 of the Sacramento City Code.
3. If the face amount of this City Contract is less than \$25,000, as a condition of receiving this Contract, I agree to notify the City in writing if the aggregate value of the City Contract referenced herein, after changes, modifications, or similar actions, equals or exceeds \$25,000 in total value.
4. I understand, to the extent that such benefits are not preempted or prohibited by federal or state law, employee benefits covered by the Ordinance, are any of the following:
 - a. Bereavement Leave
 - b. Disability, life, and other types of insurance
 - c. Family medical leave
 - d. Health benefits
 - e. Membership or membership discounts
 - f. Moving expenses
 - g. Pension and retirement benefits
 - h. Vacation
 - i. Travel benefits
 - j. Any other benefit offered to employees

I agree that should I offer any of the above listed employee benefits, that I will offer those benefits, without discrimination between employees with spouses and employees with domestic partners, and without discrimination between the spouses and domestic partners of such employees.

5. I understand that I will not be considered to be discriminating in the provision or application of employee benefits under the following conditions or circumstances:

NON-DISCRIMINATION IN EMPLOYEE BENEFITS BY CITY CONTRACTORS ORDINANCE

- a. In the event that the actual cost of providing a benefit to a domestic partner or spouse, exceeds the cost of providing the same benefit to a spouse or domestic partner of an employee, I will not be required to provide the benefit, nor shall it be deemed discriminatory, if I require the employee to pay the monetary difference in order to provide the benefit to the domestic partner or to the spouse.
- b. In the event I am unable to provide a certain benefit, despite taking reasonable measures to do so, if I provide the employee with a cash equivalent, I will not be deemed to be discriminating in the application of that benefit.
- c. If I provide employee benefits neither to employee's spouses nor to employee's domestic partners.
- d. If I provide employee benefits to employees on a basis unrelated to marital or domestic partner status.
- e. If I submit, to the Program Coordinator, written evidence of making reasonable efforts to end discrimination in employee benefits by implementing policies which are to be enacted before the first effective date after the first open enrollment process following the date the Contract is executed with the City.

I understand that any delay in the implementation of such policies may not exceed one (1) year from the date the Contract is executed with the City, and applies only to those employee benefits for which an open enrollment process is applicable.
- f. Until administrative steps can be taken to incorporate, in the infrastructure, nondiscrimination in employee benefits

The time allotted for these administrative steps will apply only to those employee benefits for which administrative steps are necessary and may not exceed three (3) months from the date the Contract is executed with the City.
- g. Until the expiration of a current collective bargaining agreement(s) where, in fact, employee benefits are governed by a collective bargaining agreement(s).
- h. I take all reasonable measures to end discrimination in employee benefits by either requesting the union(s) involved agree to reopen the agreement(s) in order for me to take whatever steps are necessary to end discrimination in employee benefits or by my ending discrimination in employee benefits without reopening the collective bargaining agreement(s).

**NON-DISCRIMINATION IN EMPLOYEE BENEFITS BY CITY CONTRACTORS
ORDINANCE**

- i. In the event I cannot end discrimination in employee benefits despite taking all reasonable measures to do so, I provide a cash equivalent to eligible employees for whom employee benefits (as listed previously), are not available.

Unless otherwise authorized in writing by the City Manager, I understand this cash equivalent must begin at the time the union(s) refuse to allow the collective bargaining agreement(s) to be reopened or no longer than three (3) months from the date the Contract is executed with the City.

6. I understand that failure to comply with the provisions of Section 5. (a) through 4. (i), above, will subject me to possible suspension and/or termination of this Contract for cause; repayment of any or all of the Contract amount disbursed by the City; debarment for future contracts until all penalties and restitution have been paid in full; deemed ineligible for future contracts for up to two (2) years; the imposition of a penalty, payable to the City, in the sum of \$50.00 for each employee, for each calendar day during which the employee was discriminated against in violation of the provisions of the Ordinance.

7. I understand and do hereby agree to provide each current employee and, within ten (10) days of hire, each new employee, of their rights under the Ordinance. I further agree to maintain a copy of each such letter provided, in an appropriate file for possible inspection by an authorized representative of the City. I also agree to prominently display a poster informing each employee of these rights.

8. I understand that I have the right to request an exemption to the benefit provisions of the Ordinance when such a request is submitted to the Procurement Services Division, in writing with sufficient justification for resolution, prior to contract award.

I further understand that the City may request a waiver or exemption to the provisions or requirements of the Ordinance, when only one contractor is available to enter into a contract or agreement to occupy and use City property on terms and conditions established by the City; when sole source conditions exist for goods, services, public project or improvements and related construction services; when there are no responsive bidders to the EBO requirements and the contract is for essential goods or services; when emergency conditions with public health and safety implications exist; or when the contract is for specialized legal services if in the best interest of the City.

9. In consideration of the foregoing, I shall defend, indemnify and hold harmless, the City, its officers and employees, against any claims, actions, damages, costs (including reasonable attorney fees), or other liabilities of any kind arising from any violation of the City's Equal Benefits Requirements or of the Ordinance by me.

**NON-DISCRIMINATION IN EMPLOYEE BENEFITS BY CITY CONTRACTORS
ORDINANCE**

I declare under penalty of perjury under the laws of the State of California that the foregoing is true and correct, and that I am authorized to bind the Contractor to the provisions of this Declaration.



Signature of Authorized Representative

8/17/2011

Date

Rodolfo Martinez L.

Print Name

owner

Title

**NON-DISCRIMINATION IN EMPLOYEE BENEFITS BY CITY CONTRACTORS
ORDINANCE**



**YOUR RIGHTS UNDER THE CITY OF SACRAMENTO'S
NON-DISCRIMINATION IN EMPLOYEE BENEFITS BY CITY CONTRACTORS
ORDINANCE**

On 8.17.2011 (date), your employer (the "Employer") entered into a contract with the City of Sacramento (the "City") for (contract details), and as a condition of that contract, agreed to abide by the requirements of the City's Non-Discrimination In Employee Benefits By City Contractors Ordinance (Sacramento City Code Section 3.54).

The Ordinance does not require the Employer to provide employee benefits. The Ordinance does require that if certain employee benefits are provided by the Employer, that those benefits be provided without discrimination between employees with spouses and employees with domestic partners, and without discrimination between the spouse or domestic partner of employees.

The Ordinance covers any employee working on the specific contract referenced above, but only for the period of time while those employees are actually working on this specific contract.

The included employee benefits are:

- Bereavement leave
- Disability, life and other types of insurance
- Family medical leave
- Health benefits
- Membership or membership discounts
- Moving expenses
- Pension and retirement benefits
- Vacation
- Travel benefits
- Any other benefits given to employees

(Employee Benefits does not include benefits that may be preempted by federal or state law.)

If you feel you have been discriminated or retaliated against by your employer in the terms and conditions of your application for employment, or in your employment, or in the application of these employee benefits, because of your status as an applicant or as an employee protected by the Ordinance, or because you reported a violation of the Ordinance, and after having exhausted all remedies with your employer,

NON-DISCRIMINATION IN EMPLOYEE BENEFITS BY CITY CONTRACTORS ORDINANCE

You May . . .

- Submit a written complaint to the City of Sacramento, Contract Services Unit, containing the details of the alleged violation. The address is:

City of Sacramento
Contract Services Unit
915 I St, 2nd Floor
Sacramento, CA 95814-2714

- Bring an action in the appropriate division of the Superior Court of the State of California against the Employer and obtain the following remedies:

- Reinstatement, injunctive relief, compensatory damages and punitive damages

- Reasonable attorney's fees and costs

**NON-DISCRIMINATION IN EMPLOYEE BENEFITS BY CITY CONTRACTORS
ORDINANCE**



**YOUR RIGHTS UNDER THE CITY OF SACRAMENTO'S
NON-DISCRIMINATION IN EMPLOYEE BENEFITS BY CITY CONTRACTORS
ORDINANCE**

If your employer provides employee benefits, they must be provided to those employees working on a City of Sacramento contract without discriminating between employees with spouses and employees with domestic partners.

The included employee benefits are:

- Bereavement leave
- Disability, life and other types of insurance
- Family medical leave
- Health benefits
- Membership or membership discounts
- Moving expenses
- Pension and retirement benefits
- Vacation
- Travel benefits
- Any other benefits given to employees

If you feel you have been discriminated against by your employer . . .

You May . . .

- o Submit a written complaint to the City of Sacramento, Contract Services Unit, containing the details of the alleged violation. The address is:

City of Sacramento
Contract Services Unit
915 I St, 2nd Floor
Sacramento, CA 95814-2714
- o Bring an action in the appropriate division of the Superior Court of the State of California against the employer and obtain reinstatement, injunctive relief, compensatory damages, punitive damages and reasonable attorney's fees and costs.

Discrimination and Retaliation Prohibited.

If you feel you have been discriminated or retaliated against by your employer in the terms and conditions of your application for employment, or in your employment, because of your status as an applicant or as an employee protected by the Ordinance, or because you reported a violation of this Ordinance . . .

You May Also . . .

Submit a written complaint to the City of Sacramento, Contract Services Unit, at the same address, containing the details of the alleged violation.

All future solicitations will incorporate the following standard language to notify potential bidders of the City Council policy regarding businesses headquartered in Arizona.

City of Sacramento Boycott of Arizona-Headquartered Businesses

On June 15, 2010, the Sacramento City Council adopted Resolution No. 2010-346 opposing two Arizona laws (SB 1070 and HB 2162) that will allow Arizona police to arrest individuals suspected of being unlawfully present in the United States and to charge immigrants with a state crime for not carrying immigration documents. Sacramento City Council Resolution No. 2010-346 also called for a boycott of the State of Arizona and businesses headquartered in Arizona until Arizona repeals or a court nullifies SB 1070 and HB 1262. Resolution No. 2010-346 provides, in pertinent part, that "where practicable and where there is no significant additional cost to the City, the City of Sacramento shall not enter into any new, amended, extended or supplemental contracts to purchase or procure goods or services from any business or entity that is headquartered in Arizona ..."

Pursuant to the provisions of Resolution No. 2010-346, the City may determine that a bid from a business or entity that is headquartered in Arizona is nonresponsive and the City may reject the bid on that basis.

Bidders that are headquartered in the United States shall certify in the space below the state where the bidder is headquartered:

CA
State Where Bidder is Headquartered

6/23/10

Title VI Language

APPENDIX A

During the performance of this contract, the contractor, for itself, its assignees and successors in interest (hereinafter referred to as the "contractor") agrees as follows:

(1) Compliance with Regulations:

The contractor shall comply with the Regulations relative to nondiscrimination in Federally-assisted programs of the Department of Transportation (hereinafter, "DOT") Title 49, Code of Federal Regulations, Part 21, as they may be amended from time to time, (hereinafter referred to as the Regulations), which are herein incorporated by reference and made a part of this contract.

(2) Nondiscrimination:

The contractor, with regard to the work performed by it during the contract, shall not discriminate on the grounds of race, color, or national origin in the selection and retention of subcontractors, including procurements of materials and leases of equipment. The contractor shall not participate either directly or indirectly in the discrimination prohibited by section 21.5 of the Regulations, including employment practices when the contract covers a program set forth in Appendix B of the Regulations.

(3) Solicitations for Subcontracts, Including Procurements of Materials and Equipment:

In all solicitations either by competitive bidding or negotiation made by the contractor for work to be performed under a subcontract, including procurements of materials or leases of equipment, each potential subcontractor or supplier shall be notified by the contractor of the contractor's obligations under this contract and the Regulations relative to nondiscrimination on the grounds of race, color, or national origin.

(4) Information and Reports:

The contractor shall provide all information and reports required by the Regulations or directives issued pursuant thereto, and shall permit access to its books, records, accounts, other sources of information, and its facilities as may be determined by the (Recipient) or the (Name of Appropriate Administration) to be pertinent to ascertain compliance with such Regulations, orders and instructions. Where any information required of a contractor is in the exclusive possession of another who fails or refuses to furnish this information the contractor shall so certify to the (Recipient), or the (Name of Appropriate Administration) as appropriate, and shall set forth what efforts it has made to obtain the information.

(5) Sanctions for Noncompliance:

In the event of the contractor's noncompliance with the nondiscrimination provisions of this contract, the (Recipient) shall impose such contract sanctions as it or the (Name of Appropriate Administration) may determine to be appropriate, including, but not limited to:

- (a) withholding of payments to the contractor under the contract until the contractor complies, and/or
- (b) cancellation, termination or suspension of the contract, in whole or in part.

(6) Incorporation of Provisions:

The contractor shall include the provisions of paragraphs (1) through (6) in every subcontract, including procurements of materials and leases of equipment, unless exempt by the Regulations, or directives issued pursuant thereto. The contractor shall take such action with respect to any subcontract or procurement as the (Recipient) or the (Name of Appropriate Administration) may direct as a means of enforcing such provisions including sanctions for non-compliance: Provided, however, that, in the event a contractor becomes involved in, or is threatened with, litigation with a subcontractor or supplier as a result of such direction, the contractor may request the (Recipient) to enter into such litigation to protect the interests of the (Recipient), and, in addition, the contractor may request the United States to enter into such litigation to protect the interests of the United States.

Green Contracting Survey (Voluntary)

The City of Sacramento and the Sacramento Metropolitan Air Quality District (SMAQMD) are conducting a joint pilot project to help meet Federal Clean Air Standards for the Sacramento region.

Attached is a Green Contracting Fleet Inventory Form. Please complete the form, remove it from the bid package and return it to SMAQMD in the postage paid envelope provided with the bid package. Please do not return the Green Contracting Fleet Inventory Form to the City of Sacramento with the bid documents or otherwise.

A limited amount of funds and other financial incentives may be available to qualified contractors participating in this joint project to assist qualified contractors with upgrading and/or replacing equipment and/or trucks.

Completing and returning the Green Contracting Fleet Inventory Form is strictly voluntary.

Voluntary Green Contracting Fleet Inventory List (On-Road Equipment)

In Partnership with the City of Sacramento and the Sacramento Metropolitan Air Quality Management District

Company Name:	
Contact Name:	
Company Address:	
City, State, ZIP:	
Company Phone:	

City Bid Information	
Department:	
Project #:	
ESBE/SBE?	

Instructions:

- a) Please enter the vehicle / equipment information for each unit used in conjunction with your City of Sacramento Bid.
- b) All fields are required for both on-road heavy-duty vehicles and off-road construction equipment over 50 HP.
- c) Electronic version available at <http://www.airquality.org/ceqa/index.shtml>
- d) For additional questions, please call (916) 874-4892

Please Submit To:
Kristian Damkier, P.E. Sacramento Metropolitan AQMD 777 12th St, 3rd Floor Sacramento, CA 95814-1908

#	VIN	License Plate	Vehicle Information			Engine Information				Annual Usage (miles)	Received Funding
			Make	Model	Year	Make	Model	Year	HP		
(ex)	1XP5AAC35RG339402	1T45678	Kenworth	T-300	2002	Cummins	ISB	2002	250	35,000	No

Voluntary Green Contracting Fleet Inventory List (Off-Road Equipment)

In Partnership with the City of Sacramento and the Sacramento Metropolitan AQMD

Company Name: _____

Contact Name: _____

Company Address: _____

City, State, ZIP: _____

Company Phone: _____

City Bid Information	
Department	_____
Project #	_____
ESBE/SBE?	_____

Instructions:

- a) Please enter the vehicle / equipment information for each unit used in conjunction with your City of Sacramento Bid.
- b) All fields are required for both on-road heavy-duty vehicles and off-road construction equipment over 50 HP.
- c) Electronic version is available at <http://www.airquality.org/ceqa/index.shtml>
- d) For additional questions, please call (916) 874-4892

Please Submit To:
Kristian Damkier, P.E. Sacramento Metropolitan AQMD 777 12th St, 3rd Floor Sacramento, CA 95814-1908

#	Equipment Serial Number	Equipment Information				Engine Information				Annual Usage (hours)
		Make	Model	Type	Year	Make	Model	Year	HP	
(ex)	48W34456	Caterpillar	631G	Scraper	2003	Caterpillar	3408E	2003	485	1,600

FOLLOWING FORMS TO BE FILLED OUT

AND SIGNED

ONLY

IF AWARDED CONTRACT

AGREEMENT
(Construction Contract Over \$25,000)

THIS AGREEMENT, dated for identification October 4, 2011 is made and entered into between the CITY OF SACRAMENTO, a municipal corporation ("City"), and RML Paving, 7431 Peacock Way, Sacramento CA 95820

The City and Contractor hereby mutually agree as follows:

1. **CONTRACT DOCUMENTS**

The Contract Documents, sometimes also referred to as the "Contract," consist of the following items, which are hereby incorporated by reference as if set forth in full in this Agreement:

The Notice to Contractors

The Proposal Form submitted by the Contractor

The Instructions to Bidders

The Emerging and Small Business Enterprise (ESBE) Requirements

The Requirements for the Non-Discrimination in Employee Benefits by City Contractors Ordinance and the Declaration of Compliance

The City's Reference Guide for Construction Contracts

The Addenda, if any

This Agreement

The Standard Specifications

The Special Provisions

The Plans and Technical Specifications

The drawings and other data and all developments thereof prepared by City pursuant to the Contract

Any modifications of any of the foregoing made or approved by City, including but not limited to duly authorized change orders.

Unless specifically noted otherwise, references to the "Standard Specifications" shall mean and refer to the Standard Specifications for Public Construction of the City of Sacramento approved by the Sacramento City Council on June 4, 2007 (Resolution No. 2007-350), and any subsequent amendments thereto approved by the Sacramento City Council or the Sacramento City Manager. Work called for in any one Contract Document and not mentioned in another is to be performed and executed as if mentioned in all Contract Documents. The table of contents, titles and headings contained in the Contract Documents are provided solely to facilitate reference to various provisions of the Contract Documents and in no way affect or limit the interpretation of the provisions to which they refer.

2. **DEFINITIONS**

Unless otherwise specifically provided herein, all words and phrases defined in the Standard Specifications shall have the same meaning and intent in this Agreement.

3. **AGREEMENT CONTROLS**

In the event of a conflict between any of the terms and conditions set forth in this Agreement and the terms and conditions set forth in other Contract Documents, the terms and conditions set forth in this Agreement shall prevail, except that the provisions of any duly authorized change order shall prevail over any conflicting provisions of this Agreement.

4. SCOPE OF CONTRACT

Contractor agrees to furnish all tools, equipment, apparatus, facilities, labor, material and transportation necessary to perform and complete in a good and workmanlike manner to the satisfaction of City, all the Work called for in the Contract Documents entitled:

2011 SPEED HUMPS PROJECT

(PN: S15101200)

~~including the Work called for in the following alternative bid items described in the Proposal Form:~~

Contractor agrees to perform such Work in the manner designated in and in strict conformity with the Contract Documents.

5. CONTRACT AMOUNT AND PAYMENTS

City agrees to pay and Contractor agrees to accept, as complete payment for the above Work, in accordance with the schedule and procedures set forth in the Contract Documents and subject to deductions, withholdings and additions as specified in the Contract Documents, a total sum that shall not exceed the total bid amount set forth in Contractor's Proposal Form. In addition, subject to deductions, withholdings and additions as specified in the Contract Documents, payment for individual items of the Work shall be computed as follows:

(A) For items of the Work for which a lump sum price is specified in Contractor's Proposal Form, Contractor shall be paid the lump sum price(s) specified in Contractor's Proposal Form; and

(B) For items of the Work for which a unit price is specified in Contractor's Proposal Form, Contractor shall be paid the sum computed at such unit price, or computed at a different price if such different price is determined by City in accordance with the Standard Specifications, based on the actual amount of each such item performed and/or furnished and incorporated in the Work; provided that in no event shall the total sum for a unit price item exceed the total bid amount set forth for such item in the Contractor's Proposal Form, unless authorized by Change Order.

6. PROGRESS PAYMENTS

Subject to the terms and conditions of the Contract, City shall cause payments to be made upon demand of Contractor as follows:

(A) On or about the first of the month, the Engineer shall present to the Contractor a statement showing the amount of labor and materials incorporated in the Work through the

twentieth (20) calendar day of the preceding month. After both Contractor and Engineer approve the statement in writing, and the City's labor compliance officer provides written approval, the City shall issue a certificate for ninety (90) percent of the amount it shall find to be due, subject to any deductions or withholdings authorized or required under the Contract or any applicable Laws or Regulations.

(B) No inaccuracy or error in said monthly estimates shall operate to release Contractor from damages arising from such Work or from enforcement of each and every provision of the Contract Documents, and City shall have the right subsequently to correct any error made in any estimate for payment.

(C) Contractor shall not be paid for any defective or improper Work.

(D) The remaining ten (10) percent of the value of the Work performed under the Contract, if unencumbered and subject to any deductions or withholdings authorized or required under the Contract or any applicable Laws or Regulations, shall be due and payable beginning thirty-five (35) days after completion and final acceptance of the Work by City; provided that the City may determine, in its sole discretion, to release up to fifty (50) % of such retention, in whole or in part, at any time. Acceptance by Contractor of the final payment shall constitute a waiver of all claims against the City arising under the Contract Documents, except for disputed claims in stated amounts that the Contractor specifically reserves in writing, but only to the extent that the Contractor has complied with all procedures and requirements applicable to the presentation and processing of such claim(s) under the Contract Documents. Contractor shall be entitled to substitute securities for retention or to direct that payments of retention be made into escrow, as provided in Public Contract Code Section 22300, upon execution of the City's Escrow Agreement for Security Deposits in Lieu of Retention.

(E) The parties agree that, for purposes of the timely progress payment requirements specified in Public Contract Code Section 20104.50, the date that the City receives a statement jointly approved by the Contractor and the Engineer as provided above shall be deemed to constitute the date that City receives an undisputed and properly submitted payment request from the Contractor. Progress payments not made within 30 days after this date may be subject to payment of interest as provided in Section 20104.50.

7. RETENTION OF SUMS CHARGED AGAINST CONTRACTOR

When, under the provisions of this Contract or any applicable Laws or Regulations, City is authorized or required to withhold, deduct or charge any sum of money against Contractor, City may deduct and retain the amount of such charge from the amount of the next succeeding progress estimate(s), or from any other moneys due or that may become due Contractor from City. If, on completion or termination of the Contract, sums due Contractor are insufficient to pay City's charges, City shall have the right to recover the balance from Contractor or its Sureties.

8. COMMENCEMENT AND PROSECUTION OF WORK

Contractor shall commence the Work not later than fifteen (15) working days after the date of the written Notice to Proceed from City to Contractor and shall diligently prosecute the Work to final completion. The phrase "commence the Work" means to engage in a continuous program on-site including, but not limited to, site clearance, grading, dredging, land filling and the fabrications, erection, or installation of the Work. The Notice to Proceed shall be issued within fifteen (15)

calendar days following execution of the Agreement by the City and the filing by Contractor of the required Bonds and proof of insurance, provided that the Engineer may delay issuance of the Notice to Proceed if the Engineer determines in the Engineer's sole discretion that conditions on the site of the Work are unsuitable for commencement of the Work. After the Notice to Proceed is issued, the continuous prosecution of Work by Contractor shall be subject only to Excusable Delays as defined in this Agreement.

9. TIME OF COMPLETION

The entire Work shall be brought to completion in the manner provided for in the Contract Documents on or before **SIXTY (60) working days** from the date of the Notice to Proceed (hereinafter called the "Completion Date") unless extensions of time are granted in accordance with the Contract Documents.

Failure to complete the entire Work by the Completion Date and in the manner provided for in the Contract Documents shall subject Contractor to liquidated damages as provided in this Agreement. Time is and shall be of the essence in the performance of the Contract and the Work.

10. PAYMENTS DO NOT IMPLY ACCEPTANCE OF WORK

The payment of any progress payment, or the acceptance thereof by Contractor, shall not constitute acceptance of the Work or any portion thereof and shall in no way reduce the liability of Contractor to replace unsatisfactory work or material, whether or not the unsatisfactory character of such work or material was apparent or detected at the time such payment was made.

11. ACCEPTANCE NOT RELEASE

Contractor shall correct immediately any defective or imperfect work or materials that may be discovered before final acceptance of the entire Work, whether or not such defect or imperfection was previously noticed or identified by the City. The inspection of the Work, or any part thereof, shall not relieve Contractor of any of its obligations to perform satisfactory work as herein specified.

Failure or neglect on the part of City or any of its officers, employees or authorized agents to discover, identify, condemn or reject defective or imperfect work or materials shall not be construed to imply an acceptance of such work or materials, if such defect or imperfection becomes evident at any time prior to final acceptance of the entire Work, nor shall such failure or neglect be construed as barring City from enforcing Contractor's warranty(ies) or otherwise recovering damages or such a sum of money as may be required to repair or rebuild the defective or imperfect work or materials whenever City may discover the same, subject only to any statutes of limitation that may apply to any such claim.

12. CITY'S RIGHT TO TAKE POSSESSION OF THE WORK IN WHOLE OR IN PART

The City shall have the right at any time to enter upon the Work and perform work not covered by this Contract, or to occupy and use a portion of the Work, prior to the date of the final acceptance of the Work as a whole, without in any way relieving Contractor of any obligations under this Contract.

13. NO WAIVER OF REMEDIES

Neither the inspection by City, its officers, employees or agents, nor any certificate or other approval for the payment of money, nor any payment for, nor acceptance of the whole or any part of the Work by City, nor any extensions of time, nor any position taken by City, its officers, employees or its agents shall operate as a waiver of any provision of the Contract Documents nor of any power herein reserved to City or any right to damages herein provided, nor shall any waiver of any breach of this Agreement be held to be a waiver of any other or subsequent breach. All remedies provided in the Contract Documents shall be taken and construed as cumulative; in addition to each and every other remedy herein provided, the City shall have any and all equitable and legal remedies that it would in any case have.

14. WARRANTY

Except as otherwise expressly provided in the Contract Documents, and excepting only items of routine maintenance, ordinary wear and tear and unusual abuse or neglect by City, Contractor warrants and guarantees all Work executed and all supplies, materials and devices of whatsoever nature incorporated in or attached to the Work, or otherwise provided as a part of the Work pursuant to the Contract, to be absolutely free of all defects of workmanship and materials for a period of one year after final acceptance of the entire Work by the City. Contractor shall repair or replace all work or material, together with any other work or material that may be displaced or damaged in so doing, that may prove defective in workmanship or material within this one year warranty period without expense or charge of any nature whatsoever to City.

In the event that Contractor shall fail to comply with the conditions of the foregoing warranty within ten (10) days after being notified of the defect in writing, City shall have the right, but shall not be obligated, to repair, or obtain the repair of, the defect and Contractor shall pay to City on demand all costs and expense of such repair. Notwithstanding anything herein to the contrary, in the event that any defect in workmanship or material covered by the foregoing warranty results in a condition that constitutes an immediate hazard to public health or safety, or any property interest, or any person, City shall have the right to immediately repair, or cause to be repaired, such defect, and Contractor shall pay to City on demand all costs and expense of such repair. The foregoing statement relating to hazards to health, safety or property shall be deemed to include both temporary and permanent repairs that may be required as determined in the sole discretion and judgment of City.

In addition to the above, the Contractor shall make a written assignment of all manufacturer's and other product warranties to the City, prior to completion and final acceptance of the Work by City.

The Contractor's Performance Bond shall secure the performance of the Contractor's obligations under this Section 14, and the Contractor and its Surety shall be jointly and severally liable for these obligations.

15. LIQUIDATED DAMAGES IF WORK NOT COMPLETED ON TIME

(A) The actual fact of the occurrence of damages and the actual amount of the damages that City would suffer if the entire Work, and/or any specified portion thereof, were not completed within the time(s) specified herein are dependent upon many circumstances and conditions that could prevail in various combinations, and for this reason, it is impracticable and extremely difficult to fix the actual damages. Damages that City would suffer in the event of such delay

include: loss of the use of the project; expenses of prolonged assignment to the project of an architectural and/or engineering staff; prolonged costs of administration, inspection, and supervision; increased operational expenses and/or impaired operation of other facilities dependent upon completion of the project; and the loss and inconvenience suffered by the public within the City of Sacramento by reason of the delay in the completion of the project or portion thereof. Accordingly, the parties agree, and by execution of this Agreement, Contractor acknowledges that it understands and agrees, that the amount(s) set forth herein as liquidated damages reflect the parties' best efforts at the time of entering into the Contract to estimate the damages that may be incurred by City and the public due to the Contractor's delay in completion of the Work and/or any specified portion thereof, and shall be presumed to be the amount of damages sustained by the failure of Contractor to complete the entire Work and/or any specified portion thereof within the time(s) specified herein.

(B) Contractor shall pay liquidated damages to City for failure to complete the entire Work by the Completion Date (as extended in accordance with the Contract Documents, if applicable) in the amount of **nine hundred dollars (\$900.00)** for each calendar day after the Completion Date (as extended in accordance with the Contract Documents, if applicable), continuing to the time at which the entire Work is completed. Such amount is the actual cash value agreed upon by the City and Contractor as the loss to City and the public resulting from Contractor's default.

The parties agree, and by execution of this Agreement, Contractor acknowledges that it understands and agrees, that the foregoing provisions provide for the imposition of liquidated damages from the Completion Date (as extended in accordance with the Contract Documents, if applicable) until the date of completion of the entire Work as determined by the Engineer in accordance with Section 8-4 of the Standard Specifications, whether or not the Work or any portion thereof is claimed or determined to be substantially complete prior to such date of completion.

THE FOLLOWING ADDITIONAL LIQUIDATED DAMAGES PROVISION(S) APPLY IF CHECKED:

In addition to the liquidated damages specified above, Contractor shall pay additional liquidated damages to City for failure to complete the portion of the Work specified below by the milestone date specified below (as such milestone date may be extended in accordance with the Contract Documents, if applicable). The amount of such additional liquidated damages shall be either *[check one]*:

a lump sum amount of _____, OR

the daily amount of _____ for each calendar day after such milestone date (as extended in accordance with the Contract Documents, if applicable), continuing to the time at which such portion of the Work is completed.

Such amount is the actual cash value agreed upon by the City and Contractor as the additional loss to City and the public resulting from Contractor's default.

<u>Portion of the Work</u>	<u>Milestone Date</u>
_____	_____
_____	_____

CONTRACTOR'S ACKNOWLEDGMENT: _____

In addition to the potential damages described above, failure to complete the entire Work within the time(s) specified herein may expose the City to penalties or fines and/or may negatively affect the availability of project funding. In recognition of these potential damages, in addition to the liquidated damages specified above, Contractor shall pay additional liquidated damages to City in the lump sum amount of _____ if the entire Work is not completed by _____. Such amount is the actual cash value agreed upon by the City and Contractor as the additional loss to City and the public resulting from Contractor's default.

CONTRACTOR'S ACKNOWLEDGMENT: _____

(C) In the event Contractor shall become liable for liquidated damages, City, in addition to all other remedies provided by law, shall have the right to withhold any and all payments that otherwise would be or become due Contractor until the liability of Contractor under this section is finally determined. City shall have the right to use and apply such payments, in whole or in part, to reimburse City for all liquidated damages due or to become due to City. Any remaining balance of such payments shall be paid to Contractor only after discharge in full of all liability incurred by Contractor under this section or otherwise under any provision of the Contract Documents or any applicable Law or Regulation. If the sum so retained by City is not sufficient to discharge all such liabilities of Contractor, Contractor shall continue to remain liable to City until all such liabilities are satisfied in full. No failure by City to withhold any payment as specified above shall in any manner be construed to constitute a release of any such liabilities nor a waiver of the City's right to withhold payment for such liabilities.

16. INDEMNITY AND HOLD HARMLESS

(A) Contractor shall defend, hold harmless and indemnify the City, its officers, employees, and agents, and each and every one of them, from and against any and all actions, damages, costs, liabilities, claims, demands, losses, judgments, penalties, costs and expenses of every type and description, whether arising on or off the site of the Work, including, but not limited to, any fees and/or costs reasonably incurred by City's staff attorneys or outside attorneys and any fees and expenses incurred in enforcing this provision (hereafter collectively referred to as "Liabilities"), including but not limited to Liabilities arising from personal injury or death, damage to personal, real or intellectual property or the environment, contractual or other economic damages, or regulatory penalties, arising out of or in any way connected with performance of or failure to perform the Work by the Contractor, any subcontractor or agent, anyone directly or indirectly employed by any of them or anyone for whose acts any of them may be liable, whether or not (i) such Liabilities are caused in part by a party indemnified hereunder, or (ii) such Liabilities are litigated, settled or reduced to judgment; provided that the foregoing indemnity does not apply to liability for damages for death or bodily injury to persons, injury to property, or other loss, damage or expense to the extent arising from (i) the sole negligence or willful misconduct of, or defects in design furnished by, City, its agents, servants, or independent contractors who are directly responsible to City, or (ii) the active negligence of City.

(B) The existence or acceptance by City of any of the insurance policies or coverages described in this Agreement shall not affect or limit any of City's rights under this Section 16, nor shall the limits of such insurance limit the liability of Contractor hereunder. The provisions

of this Section 16 shall survive any expiration or termination of the Contract.

17. CONTRACTOR SHALL ASSUME RISKS

Until the completion and final acceptance by City of all Work under this Contract, the Work shall be under Contractor's responsible care and charge, and Contractor, at no cost to City, shall rebuild, repair, restore and make good all injuries, damages, re-erections, and repairs occasioned or rendered necessary by accidental causes of any nature, to all or any portions of the Work.

18. GENERAL LIABILITY OF CONTRACTOR

Except as otherwise herein expressly stipulated, Contractor shall perform all the Work and furnish all the labor, materials, tools, equipment, apparatus, facilities, transportation, power and light, and appliances, necessary or proper for performing and completing the Work herein required in the manner and within the time herein specified. The mention of any specific duty or liability of Contractor shall not be construed as a limitation or restriction of any general liability or duty of Contractor, and any reference to any specific duty or liability shall be construed to be solely for the purpose of explanation.

19. INSURANCE

During the entire term of this Contract and until completion and final acceptance of the Work as provided in the Contract Documents, Contractor shall maintain in full force and effect the insurance coverage described in this section.

Full compensation for all premiums that Contractor is required to pay for the insurance coverage described herein shall be included in the compensation specified for performance of the Work under the Contract. No additional compensation will be provided for Contractor's insurance premiums.

It is understood and agreed by the Contractor that its liability to the City shall not in any way be limited to or affected by the amount of insurance coverage required of or carried by the Contractor.

(A) Minimum Scope and Limits of Insurance Coverage

(1) Commercial General Liability Insurance, providing coverage at least as broad as ISO CGL Form 00 01 on an occurrence basis for bodily injury, including death, of one or more persons, property damage and personal injury, with limits of not less than one million dollars (\$1,000,000) per occurrence. The policy shall provide contractual liability and products and completed operations coverage for the term of the policy.

(2) Automobile Liability Insurance providing coverage at least as broad as ISO Form CA 00 01 on an occurrence basis for bodily injury, including death, of one or more persons, property damage and personal injury, with limits of not less than one million dollars (\$1,000,000) per occurrence. The policy shall provide coverage for owned, non-owned and/or hired autos as appropriate to the operations of the Contractor.

(3) Workers' Compensation Insurance with statutory limits, and Employers' Liability Insurance with limits of not less than one million dollars (\$1,000,000). The Worker's Compensation policy shall include a waiver of subrogation.

(B) Additional Insured Coverage

(1) Commercial General Liability Insurance: The City, its officials, employees and volunteers shall be covered by policy terms or endorsement as additional insureds as respects general liability arising out of activities performed by or on behalf of Contractor, products and completed operations of Contractor, and premises owned, leased or used by Contractor. The general liability additional insured endorsement must be signed by an authorized representative of the insurance carrier.

If the policy includes a blanket additional insured endorsement or contractual additional insured coverage, the above signature requirement may be fulfilled by submitting that document with a signed declaration page referencing the blanket endorsement or policy form.

(2) Automobile Liability Insurance: The City, its officials, employees and volunteers shall be covered by policy terms or endorsement as additional insureds as respects auto liability.

(C) Other Insurance Provisions

The policies are to contain, or be endorsed to contain, the following provisions:

(1) Contractor's insurance coverage shall be primary insurance as respects City, its officials, employees and volunteers. Any insurance or self-insurance maintained by City, its officials, employees or volunteers shall be in excess of Contractor's insurance and shall not contribute with it.

(2) Any failure to comply with reporting provisions of the policies shall not affect coverage provided to City, its officials, employees or volunteers.

(3) Coverage shall state that Contractor's insurance shall apply separately to each insured against whom claim is made or suit is brought, except with respect to the limits of the insurer's liability.

(4) City will be provided with thirty (30) days written notice of cancellation or material change in the policy language or terms.

(D) Acceptability of Insurance

Insurance shall be placed with insurers with a Bests' rating of not less than A:V. Self-insured retentions, policy terms or other variations that do not comply with the requirements of this Section 19 must be declared to and approved by the City Risk Management Division in writing prior to execution of this Agreement.

(E) Verification of Coverage

(1) Contractor shall furnish City with certificates and required endorsements evidencing the insurance required. The certificates and endorsements shall be forwarded to the City representative designated by City. Copies of policies shall be delivered to the City on demand. Certificates of insurance shall be signed by an authorized representative of the insurance carrier.

(2) The City may withdraw its offer of contract or cancel the Contract if the certificates of insurance and endorsements required have not been provided prior to execution of this Agreement. The City may withhold payments to Contractor and/or cancel the Contract if the insurance is canceled or Contractor otherwise ceases to be insured as required herein.

(F) Subcontractors

Contractor shall require and verify that all subcontractors maintain insurance coverage that meets the minimum scope and limits of insurance coverage specified in subsection A, above.

20. FAILURE TO MAINTAIN BONDS OR INSURANCE

If, at any time during the performance of this Contract, Contractor fails to maintain any item of the bonds and/or insurance required under the Contract in full force and effect, Contractor shall immediately suspend all work under the Contract and notify City in writing of such failure. After such notice is provided, or if City discovers such failure and notifies Contractor, the City thereafter may withhold all Contract payments due or that become due until notice is received by City that such bonds and/or insurance have been restored in full force and effect and that the premiums therefor have been paid for a period satisfactory to the Division of Risk Management. Contractor shall not resume work until notified by City to do so, and the City shall have no responsibility or liability for any costs incurred by Contractor as a result of such suspension of Work.

In addition to the foregoing, any failure to maintain any item of the required bonds and/or insurance at any time during the performance of this Contract will be sufficient cause for termination of the Contract by City.

The Contractor shall be solely responsible for, and shall defend, indemnify and hold harmless the City, its officers, employees and agents against and from, any and all damages, claims, losses, actions, costs or other expenses of any kind incurred by any party as a direct or indirect result of any suspension of Work or termination of the Contract under the provisions of this Section.

21. EXCUSABLE DELAYS

For the purpose of these Contract Documents, the term "Excusable Delay" shall mean, and is limited to, delay caused directly by: acts of God; acts of a public enemy; fires; inclement weather as determined by the Engineer; riots; insurrections; epidemics; quarantine restrictions; strikes; lockouts; sitdowns; acts of a governmental agency; priorities or privileges established for the manufacture, assemble, or allotment of materials necessary in the Work by order, decree or otherwise of the United States or by any department, bureau, commission, committee, agent, or administrator of any legally constituted public authority; changes in the Work ordered by City insofar as they necessarily require additional time in which to complete the Work; the prevention

of Contractor from commencing or prosecuting the Work because of the acts of others, excepting Contractor's subcontractors or suppliers; or the prevention of Contractor from commencing or prosecuting the Work because of a Citywide failure of public utility service.

The term "Excusable Delay" shall specifically not include: (i) any delay that could have been avoided by the exercise of care, prudence, foresight and diligence on the part of Contractor; (ii) any delay in the prosecution of any part of the Work that does not constitute a Controlling Operation, whether or not such delay is unavoidable; (iii) any reasonable delay resulting from time required by City for review of any Contractor submittals and for the making of surveys, measurements and inspection; and, (iv) any delay arising from an interruption in the prosecution of the Work on account of reasonable interference by other Contractors employed by City that does not necessarily prevent the completion of the entire Work within the time specified. Excusable Delays, if any, shall operate only to extend the Completion Date (not in excess of the period of such delay as determined by City) and shall not under any circumstances increase the amount City is required to pay Contractor except as otherwise provided in these Contract Documents.

22. CONTRACTOR TO SERVE NOTICE OF DELAYS

Whenever Contractor foresees any delay in the prosecution of the Work, and in any event as soon as possible (not to exceed a period of ten (10) calendar days) after the initial occurrence of any delay that Contractor regards as or may later claim to be an Excusable Delay, the Contractor shall notify the Engineer in writing of such delay and its cause, in order that the Engineer: (i) may take immediate steps to prevent if possible the occurrence or continuance of the delay; or (ii) if this cannot be done, may determine whether the delay is to be considered excusable, how long it continues, and to what extent the prosecution and completion of the Work are delayed thereby. Said written notice shall constitute an application for an extension of time only if the notice requests such an extension and sets forth the Contractor's estimate of the additional time required together with a full description of the cause of the delay relied upon.

After the completion of any part or whole of the Work, the Engineer, in estimating the amount due Contractor, will assume that any and all delays that may have occurred in its prosecution and completion were not Excusable Delays, except for such delays for which the Contractor has provided timely written notice as required herein, and that the Engineer has found to be excusable. Contractor shall not be entitled to claim Excusable Delay for any delay for which the Contractor failed to provide such timely written notice.

23. EXTENSION OF TIME

If the Contractor complies with Section 22, above, and the Engineer finds a delay claimed by the Contractor to be an Excusable Delay, the Contractor shall be allowed an extension of time to complete the Work that is proportional to the period of Excusable Delay determined by the Engineer, subject to the approval by City of a change order granting such time extension. During a duly authorized extension for an Excusable Delay, City shall not charge liquidated damages against the Contractor for such delay.

If the City extends the time to complete the Work as provided herein, such extension shall in no way release any warranty or guarantee given by Contractor pursuant to the provisions of the Contract Documents, nor shall such extension of time relieve or release the sureties of the Bonds provided pursuant to the Contract Documents. By executing such Bonds, the Sureties shall be deemed to have expressly agreed to any such extension of time. The granting of any extension of

time as provided herein shall in no way operate as a waiver on the part of City of its rights under this Contract, excepting only extension of the Completion Date for such period of Excusable Delay as may be determined by the Engineer and approved by a duly authorized change order.

24. NO PAYMENT FOR DELAYS

No damages or compensation of any kind shall be paid to Contractor or any subcontractor because of delays in the progress of the Work whether or not such delays qualify for extension of time under this Agreement; except that this provision shall not preclude the recovery of damages for a delay caused by the City that is unreasonable under the circumstances and that is not within the contemplation of the parties, provided that the Contractor timely submits all such written notice(s) and fully complies with such other procedures as may be specified in the Contract Documents or any Laws or Regulations for Contractor to claim damages for such delay.

25. CHANGES IN THE WORK

Changes in the Work authorized or directed in accordance with the Contract Documents and extensions of time of completion made necessary by reason thereof shall not in any way release any warranty or guarantee given by Contractor pursuant to the provisions of the Contract Documents, nor shall such changes in the Work relieve or release the Sureties on Bonds provided pursuant to the Contract Documents. By executing such Bonds, the Sureties shall be deemed to have expressly agreed to any such change in Work and to any extension of time made by reason thereof.

26. TERMINATION AFTER COMPLETION DATE

In addition to any other rights City may have, if any services or work required under the Contract (including but not limited to punch list items) are not completed as of the Completion Date (as adjusted by any extensions of time for Excusable Delays granted pursuant to the Contract Documents), City may terminate the Contract at any time after the Completion Date (as adjusted by any extensions of time for Excusable Delays granted pursuant to the Contract Documents), by providing a written notice to Contractor specifying the date of termination. Such notice also may specify conditions or requirements that Contractor must meet to avoid termination of the Contract on such date. If Contractor fails to fulfill all such conditions and requirements by such termination date, or, if no such conditions or requirements are specified, Contractor shall cease rendering services and performing work on such termination date, and shall not be entitled to receive any compensation for services rendered or work performed after such termination date. In the event of such termination, Contractor shall remain liable to City for liquidated damages incurred for any period of time prior to the termination date.

In addition to any other charges, withholdings or deductions authorized under the Contract or any Laws or Regulations, if City terminates the Contract pursuant to this section, City may withhold and deduct from any payment and/or retention funds otherwise due Contractor any sum necessary to pay the City's cost of completing or correcting, or contracting for the completion or correction of, any services or work under the Contract that are not completed to the satisfaction of the City or that otherwise are deficient or require correction as of such termination date, including but not limited to incomplete punch list items. Such costs shall include all of the City's direct and indirect costs incurred to complete or correct such services or work, including the City's administrative and overhead costs. If the amount of payment(s) and/or retention funds otherwise due the Contractor are insufficient to pay such costs, City shall have the right to recover the balance of such costs from the Contractor and/or its Surety(ies).

27. TERMINATION FOR CONVENIENCE

Upon written notice to the Contractor, the City may at any time, without cause and without prejudice to any other right or remedy of the City, elect to terminate the Contract for the convenience of City. In such case, the Contractor shall be paid (without duplication of any items, and after deduction and/or withholding of any amounts authorized to be deducted or withheld by the Contract Documents or any Laws or Regulations):

(A) For Work executed in accordance with the Contract Documents prior to the effective date of termination and determined to be acceptable by the Engineer, including fair and reasonable sums for overhead and profit on such Work;

(B) For reasonable claims, costs, losses, and damages incurred in settlement of terminated contracts with subcontractors, suppliers, and others; and

(C) For reasonable expenses directly attributable to termination.

Contractor shall not be paid for any loss of anticipated profits or revenue for any Work not performed prior to termination, nor for any economic loss arising out of or resulting from such termination, except for the payments listed in this section. Contractor's warranty under Section 14 of this Agreement shall apply, and Contractor shall remain responsible for all obligations related to such warranty, with respect to all portions of the Work performed prior to the effective date of the termination for convenience pursuant to this section. The City shall be entitled to have any or all remaining Work performed by other contractors or by any other means at any time after the effective date of a termination for convenience pursuant to this section.

28. TERMINATION FOR BREACH OF CONTRACT

If Contractor abandons the Work under this Contract, or if the Contract or any portion of the Contract is sublet or assigned without the consent of the City, or if the Engineer determines in the Engineer's sole discretion that the conditions of the Contract in respect to the rate of progress of the Work are not being fulfilled or any part thereof is unnecessarily delayed, or if Contractor violates or breaches, or fails to execute in good faith, any of the terms or conditions of the Contract, or if Contractor refuses or fails to supply enough properly skilled labor or materials or refuses or fails to make prompt payment to subcontractors for material or labor, or if Contractor disregards any Laws or Regulations or proper instruction or orders of the Engineer, then, notwithstanding any provision to the contrary herein, the City may give Contractor and its Sureties written notification to immediately correct the situation or the Contract shall be terminated.

In the event that such notice is given, and, in the event such situation is not corrected, or arrangements for correction satisfactory to the City are not made, within ten (10) calendar days from the date of such notice or within such other period of time as may be specified by the City in the notice, the Contract shall upon the expiration of said period cease and terminate. In the event of any such termination, City may take over the Work and prosecute the Work to completion, or otherwise, and the Contractor and its Sureties shall be liable to City for any cost occasioned City thereby, as hereinafter set forth.

In the event City completes the Work, or causes the Work to be completed, no payment of any kind shall be made to Contractor until the Work is complete. The cost of completing the Work, including but not limited to, extra costs of project administration and management incurred by City, both direct or indirect, shall be deducted from any sum then due, or that becomes due, to Contractor from City. If sums due to Contractor from City are less than the cost of completing the Work, Contractor and its Sureties shall pay City a sum equal to this difference on demand. In the event City completes the Work, and there is a sum remaining due to Contractor after City deducts the costs of completing the Work, then City shall pay such sum to Contractor. The Contractor and Contractor's Sureties shall be jointly and severally liable for all obligations imposed on Contractor hereunder.

No act by City before the Work is finally accepted, including, but not limited to, exercise of other rights under the Contract, actions at law or in equity, extensions of time, payments, assessments of liquidated damages, occupation or acceptance of any part of the Work, waiver of any prior breach of the Contract or failure to take action pursuant to this section upon the happening of any prior default or breach of Contractor, shall be construed to be a waiver or estoppel of the City's right to act pursuant to this Section upon any subsequent event, occurrence or failure by Contractor to fulfill the terms and conditions of the Contract. The rights of City to terminate the Contract pursuant to this Section and pursuant to Sections 26 and 27 are cumulative and are in addition to all other rights of City pursuant to the Contract and at law or in equity.

29. CONTRACTOR BANKRUPT

If Contractor should commence any bankruptcy proceeding, or if Contractor is adjudged a bankrupt, or if Contractor makes any assignment for the benefit of creditors, or if a receiver is appointed on account of Contractor's insolvency, then the City may, without prejudice to any other right or remedy, terminate the Contract and complete the work by giving notice as provided in Section 28 above.

30. SURETIES' OBLIGATIONS UPON TERMINATION

If the City terminates the Contract pursuant to Section 28 or Section 29 above:

(A) The Surety under Contractor's performance bond shall be fully responsible for all of the Contractor's remaining obligations of performance under the Contract as if the Surety were a party to the Contract, including without limitation Contractor's obligations, as provided in the Contract Documents, to complete and provide a one-year warranty of the entire Work, pay liquidated damages and indemnify, defend and hold harmless City, up to the full amount of the performance bond.

(B) The Surety under Contractor's payment bond shall be fully responsible for the performance of all of the Contractor's remaining payment obligations for work, services, equipment or materials performed or provided in connection with the Work or any portion thereof, up to the full amount of the payment bond.

31. ACCOUNTING RECORDS OF CONTRACTOR

During performance of the Contract and for a period of three (3) years after completing the entire Work, Contractor shall maintain all accounting and financial records related to the Contract and performance of the Work in accordance with generally accepted accounting

practices, and shall keep and make such records available for inspection and audit by representatives of the City upon reasonable written notice.

32. USE TAX REQUIREMENTS

- (A) Use Tax Direct Payment Permit For all leases and purchases of materials, equipment, supplies, or other tangible personal property used to perform the Contract and shipped from outside California, the Contractor and any subcontractors leasing or purchasing such materials, equipment, supplies or other tangible personal property shall obtain a Use Tax Direct Payment Permit from the California State Board of Equalization ("SBE") in accordance with the applicable SBE criteria and requirements.
- (B) Sellers Permit For any construction contract and any construction subcontract in the amount of \$5,000,000 or more, Contractor and the subcontractor(s) shall obtain sellers permits from the SBE and shall register the jobsite as the place of business for the purpose of allocating local sales and use tax to the City. Contractor and its subcontractors shall remit the self-accrued use tax to the SBE, and shall provide a copy of each remittance to the City.
- (C) The above provisions shall apply in all instances unless prohibited by the funding source for the Contract.

IN WITNESS WHEREOF, the parties hereto have signed this Agreement on the date set for opposite their names.

CONTRACTOR

Under penalty of perjury, I certify that the taxpayer identification number and all other information provided here are correct.

DATE 9/20/11

BY 
Rodolfo Martinez
Print Name
owner
Title

BY _____

Print Name _____

Title _____

Federal ID# _____

51-0524897

State ID# _____

244-9083-1

City of Sacramento Business Operation Tax Certificate No. (City will not award contract until Certificate Number is obtained)

Type of Business Entity (check one):

- Individual/Sole Proprietor
- Partnership
- Corporation
- Limited Liability Company
- Other (please specify: _____)

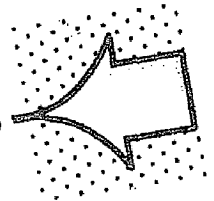

CITY OF SACRAMENTO
a municipal corporation

DATE _____

BY _____

Original/Approved As To Form:

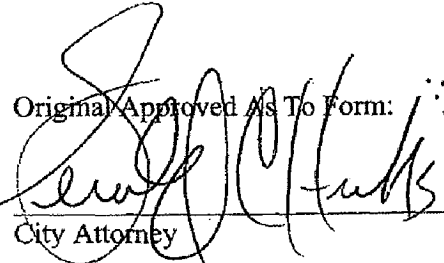
City Attorney

Attest:

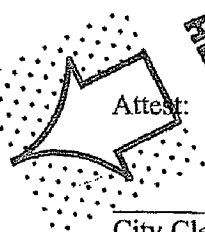

City Clerk

City Manager

**CITY OF SACRAMENTO
PERFORMANCE BOND**

Department of Transportation
Page 1 of 1

Bond No.: 71167590

Premium: \$5,029.00

WHEREAS, the City of Sacramento, State of California, hereinafter called City, has conditionally awarded to RML Paving 7431 Peacock Way Sacramento CA 95820 as principal, hereinafter called Contractor, a contract for construction of:

**2011 SPEED HUMPS PROJECT
(PN: S15101200)**

which contract is by reference incorporated herein and made a part hereof as if the Surety named below were a party to the contract, and is hereinafter referred to as the Contract; and

WHEREAS, under the terms of the Contract, Contractor is required to furnish a bond for the faithful performance of the Contract.

NOW, THEREFORE, we the Contractor and (here insert full name and address of Surety):
Western Surety Company PO Box 5077, Sioux Falls, SD 57117-5077

a corporation duly authorized and admitted to transact business and issue surety bonds in the State of California, hereinafter called Surety, are held and firmly bound unto the City, as obligee, in the sum of: ONE HUNDRED SIXTY SEVEN THOUSAND SIX HUNDRED THIRTY ONE DOLLARS FORTY FIVE CENTS (\$167,631.45), for the payment of which sum well and truly to be made, we the Contractor and Surety bind ourselves, our heirs, executors, administrators, successors and assigns, jointly and severally. The condition of this obligation is such that, if the Contractor, Contractor's heirs, executors, administrators, successors or assigns, shall in all things stand to and abide by, and well and truly keep and fully perform all covenants, conditions and agreements required to be kept and performed by Contractor in the Contract and any changes, additions or alterations made thereto, to be kept and performed at the time and in the manner therein specified, and in all respects according to their true intent and meanings, and shall indemnify and save harmless the City, its officers, employees and agents, as therein provided, then the Surety's obligations under the Contract and this bond shall be null and void; otherwise they shall be and remain in full force and effect. This obligation shall remain in full force and effect through the end of the Contract warranty period, which will expire one year after the completion of work date specified in the Notice of Completion filed for the above-named project.

As part of the obligations secured hereby and in addition to the sum specified above, there shall be included all costs, expenses and fees, including attorney's fees, reasonably incurred by City in successfully enforcing such obligations, all to be taxed as costs and included in any judgment rendered.

The Surety, for value received, hereby stipulates and agrees that no change, extension of time, alteration or addition to the terms of the Contract or to the work to be performed thereunder or to the specifications accompanying the same shall in any way affect its obligations on this bond, and it does hereby waive notice of any such change, extension, alteration or addition.

IN WITNESS WHEREOF, this instrument has been duly executed by authorized representatives of the Contractor and Surety. SIGNED AND SEALED on September 14, 2011
RML Paving

(Contractor) (Seal)
By Rodolfo Martinez
Title owner

Western Surety Company
(Surety) (Seal)
By R. Page
Title Attorney-in-Fact

ORIGINAL APPROVED AS TO FORM:

[Signature]
City Attorney

Agent Name and Address Surety1
3225 Monier Circle, Rancho Cordova, CA 95742
Agent Phone # 877-654-2327
Surety Phone # 1-800-331-6053
California License # 0E59230

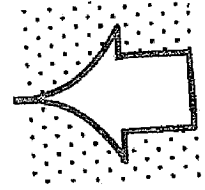

HERE

**CITY OF SACRAMENTO
PAYMENT BOND**

Department of Transportation
Page 1 of 1

Bond No.: 71167590
Premium: Included in performance bond.

WHEREAS, the City of Sacramento, in the State of California, hereinafter called City, has conditionally awarded to: RML Paving 7431 Peacock Way Sacramento CA 95820 hereinafter called Contractor, a contract for construction of:

**2011 SPEED HUMPS PROJECT
(PN: S15101200)**

which contract is by reference incorporated herein and made a part hereof, and is hereinafter referred to as the Contract; and

WHEREAS, under the terms of the Contract, Contractor is required to furnish a good and sufficient payment bond to secure the claims to which reference is made in Title 15(commencing with Section 3082) of Part 4 of Division 3 of the California Civil Code.

NOW, THEREFORE, we the Contractor and (*here insert full name and address of Surety*):
Western Surety Company PO Box 5077, Sioux Falls, SD 57117-5077

a corporation duly authorized and admitted to transact business and issue surety bonds in the State of California, hereinafter called Surety, are held and firmly bound unto the City, and unto all subcontractors, laborers, material men and other persons employed in the performance of the Contract and referred to in the aforesaid Civil Code in the sum of ONE HUNDRED SIXTY SEVEN THOUSAND SIX HUNDRED THIRTY ONE DOLLARS FORTY FIVE CENTS (\$167,631.45), the condition that if Contractor shall fail to pay for any materials or equipment furnished or used in performance of the Contract, or for any work or labor thereon of any kind, or for amounts due under the Unemployment Insurance Act with respect to such work or labor, or for any amounts required to be deducted, withheld, and paid over to the Franchise Tax Board from the wages of employees of the Contractor and all subcontractors with respect to such work or labor, then the Surety shall pay the same in an amount not exceeding the sum specified above. If suit is brought upon this bond, Surety shall pay, in addition to the above sum, all costs, expenses and fees, including attorney's fees, reasonably incurred by any party in successfully enforcing the obligation secured hereby, all to be taxed as costs and included in any judgment rendered. Should the condition of this bond be fully performed, then this obligation shall become null and void, otherwise it shall be and remain in full force and effect, and shall bind Contractor, Surety, their heirs, executors, administrators, successors and assigns, jointly and severally.

It is hereby stipulated and agreed that this bond shall inure to the benefit of all persons, companies, corporations, political subdivisions and State agencies entitled to file claim under Title 15 (commencing with Section 3082) of Part 4 of Division 3 of the Civil Code, so as to give a right of action to them or their assigns in any suit brought upon this bond. The Surety, for value received, hereby stipulates and agrees that no change, extension of time, alteration or addition to the terms of the Contract or to the work to be performed thereunder or to the specifications accompanying the same shall in any way affect its obligations on this bond, and it does hereby waive notice of any such change, extension, alteration or addition.

IN WITNESS WHEREOF, this instrument has been duly executed by authorized representatives of the Contractor and Surety. SIGNED AND SEALED on September 14, 2011
RML Paving

(Contractor) (Seal)
By Rodolfo Martinez
Title owner

ORIGINAL APPROVED AS TO FORM

[Signature]
City Attorney

Western Surety Company
(Surety) (Seal)
[Signature]
Title Henry R. Page, Attorney-in-Fact
Agent Name and Address Surety
3225 Monier Circle, Rancho Cordova, CA 95742
Agent Phone # 877-654-2327
Surety Phone # 1-800-331-6053
California License # 0E59230

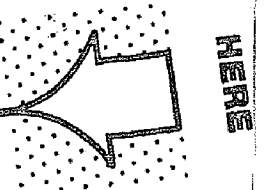

Western Surety Company

POWER OF ATTORNEY APPOINTING INDIVIDUAL ATTORNEY-IN-FACT

Know All Men By These Presents, That WESTERN SURETY COMPANY, a South Dakota corporation, is a duly organized and existing corporation having its principal office in the City of Sioux Falls, and State of South Dakota, and that it does by virtue of the signature and seal herein affixed hereby make, constitute and appoint

John T Page, Barry R Page, Amy Elizabeth Johnston, Individually

of Rancho Cordova, CA, its true and lawful Attorney(s)-in-Fact with full power and authority hereby conferred to sign, seal and execute for and on its behalf bonds, undertakings and other obligatory instruments of similar nature

- In Unlimited Amounts -

and to bind it thereby as fully and to the same extent as if such instruments were signed by a duly authorized officer of the corporation and all the acts of said Attorney, pursuant to the authority hereby given, are hereby ratified and confirmed.

This Power of Attorney is made and executed pursuant to and by authority of the By-Law printed on the reverse hereof, duly adopted, as indicated, by the shareholders of the corporation.

In Witness Whereof, WESTERN SURETY COMPANY has caused these presents to be signed by its Senior Vice President and its corporate seal to be hereto affixed on this 28th day of March, 2011.

WESTERN SURETY COMPANY



Paul T. Bruflat

Paul T. Bruflat, Senior Vice President

State of South Dakota }
County of Minnehaha } SS

On this 28th day of March, 2011, before me personally came Paul T. Bruflat, to me known, who, being by me duly sworn, did depose and say: that he resides in the City of Sioux Falls, State of South Dakota; that he is the Senior Vice President of WESTERN SURETY COMPANY described in and which executed the above instrument; that he knows the seal of said corporation; that the seal affixed to the said instrument is such corporate seal; that it was so affixed pursuant to authority given by the Board of Directors of said corporation and that he signed his name thereto pursuant to like authority, and acknowledges same to be the act and deed of said corporation.

My commission expires
November 30, 2012

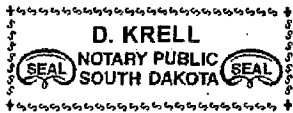

D. Krell

D. Krell, Notary Public

CERTIFICATE

I, L. Nelson, Assistant Secretary of WESTERN SURETY COMPANY do hereby certify that the Power of Attorney hereinabove set forth is still in force, and further certify that the By-Law of the corporation printed on the reverse hereof is still in force. In testimony whereof I have hereunto subscribed my name and affixed the seal of the said corporation this 14 day of September, 2011.



WESTERN SURETY COMPANY

L. Nelson

L. Nelson, Assistant Secretary

ACKNOWLEDGMENT

State of California
County of Sacramento)

On 09/14/2011 before me, Amanda Peart, Notary Public
(insert name and title of the officer)

personally appeared Barry R. Page,
who proved to me on the basis of satisfactory evidence to be the person(s) whose name(s) is/are
subscribed to the within instrument and acknowledged to me that he/she/they executed the same in
his/her/their authorized capacity(ies), and that by his/her/their signature(s) on the instrument the
person(s), or the entity upon behalf of which the person(s) acted, executed the instrument.

I certify under PENALTY OF PERJURY under the laws of the State of California that the foregoing
paragraph is true and correct.

WITNESS my hand and official seal.

Signature Amanda Peart (Seal)

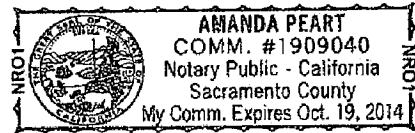

Company Profile

WESTERN SURETY COMPANY

P.O. BOX 5077

SIoux FALLS, SD 57117-5077

Agent for Service of Process

JERE KEPRIOS, C/O CT CORPORATION SYSTEM 818 WEST SEVENTH STREET, 2ND FLOOR

LOS ANGELES, CA 90017 JERE KEPRIOS, C/O CT CORPORATION SYSTEM 818 WEST

SEVENTH ST LOS ANGELES, CA 90017

Unable to Locate the Agent for Service of Process?

Reference Information

NAIC #:	13188
NAIC Group #:	<u>0218</u>
California Company ID #:	0761-7
Date authorized in California:	July 29, 1930
License Status:	UNLIMITED-NORMAL
Company Type:	Property & Casualty
State of Domicile:	SOUTH DAKOTA

Lines of Insurance Authorized to Transact

The company is authorized to transact business within these lines of insurance. For an explanation of any of these terms, please refer to the [glossary](#).

LIABILITY
SURETY

Company Complaint Information

[Company Enforcement Action Documents](#)
[Company Performance & Comparison Data](#)
[Composite Complaint Studies](#)

Want More?

Help Me Find a Company Representative in My Area

Last Revised - May 26, 2011 01:14 PM
Copyright © California Department of Insurance

Construction and Demolition (C&D) Debris Recycling Requirements

As a condition of receiving this Contract, Contractor agrees to fully comply with the requirements specified herein for all demolition projects, as well as projects with a valuation of \$250,000 or more:

1. **Definitions.** For purposes of this section, the following terms, words and phrases shall have the following meanings:

"Certified C&D sorting facility" means a facility that receives C&D debris and/or processes C&D debris into its component material types for reuse, recycling, and disposal of residuals and possesses a valid certificate as a C&D sorting facility from the Sacramento Regional County Solid Waste Authority.

"Construction and demolition debris" or "C&D debris" means used or commonly discarded materials resulting from construction, repair, remodel or demolition operations on any pavement, house, building, or other structure, or from landscaping that are not hazardous as defined in California Health and Safety Code section 25100 et seq. Such materials include, but are not limited to, concrete, asphalt, wood, metal, brick, dirt, sand, rock, gravel, plaster, glass, gypsum wallboard, cardboard and other associated packaging, roofing material, ceramic tile, carpeting, masonry, plastic pipe, trees, and other vegetative matter resulting from land clearing and landscaping.

"Divert" or "diversion" means to use materials for any purpose other than disposal in a landfill or transformation facility. Methods to divert materials include on-site reuse of the materials, delivery of materials from the project site to a certified C&D sorting facility or a recycling facility, or other methods as approved in regulations promulgated by the City Department of Utilities.

"Franchised waste hauler" means a person who possesses a valid commercial solid waste collection franchise issued by the Sacramento Regional County Solid Waste Authority.

"Mixed C&D debris" means loads that include commingled recyclable and non-recyclable C&D debris generated at a project site.

"Recyclable C&D debris" means C&D debris required to be diverted from landfills as specified in the Waste Management Plan and returned to the economic mainstream in the form of raw material for new, reused or reconstituted products that meet the quality standards necessary to be used in the marketplace.

"Recycling facility" means a facility or operation that receives, processes, and transfers source-separated recyclable materials.

"Source-separated C&D debris" means recyclable C&D debris that is separately sorted and containerized at the site of generation by individual material type and segregated from mixed C&D debris prior to collection and transporting.

"Waste log" means a record detailing the management of C&D debris generated by the covered project, including the date and weight/volume of material by type that was salvaged, reused, recycled or disposed.

2. **Waste Management Plan.** A completed WMP (see **Attachment 1**) must be submitted to and approved by the City prior to commencing any work on the project. The WMP must specify the types of C&D debris that will be generated from the project; the manner in which C&D debris will be managed and/or stored on the project site; the manner in which recyclable C&D debris generated from the project will be recycled or reuse; the person who will haul, collect or transport the recyclable C&D debris from the project site; and the certified C&D sorting facility or recycling facility where recyclable C&D debris will be delivered. The WMP must be approved by the City prior to commencing any work on the project.

C&D Debris Waste Log

C&D Debris Waste Management Plan
 City of Sacramento Solid Waste Services
 2812 Meadowview Road, Building 1
 Sacramento, CA 95832
 Phone: (916) 808-4839 / Fax: (916) 808-4999
 C&D@cityofsacramento.org

Project address: _____

This waste log, and copies of supporting weight tickets, must be submitted to Solid Waste within 30 days of submitting the project completion report. The waste log and weight tickets must also be kept on file for one year after project completion.

Date	Hauler	Material	Destination	Amount

- Hauler:** Indicate the Franchisee, Self-Hauler, City of Sacramento, or other hauler who removed the material offsite.
- Material:** Indicate appropriate category: Scrap Metal, Inert Materials, Cardboard, Wooden Pallets, or Clean Wood Waste.
- Destination:** Indicate the facility that received the material for disposal or recycling
- Amount:** Indicate the weight. If weight is not known, put volume.

C&D Debris Waste Management Plan

C&D Debris Waste Management Plan
 City of Sacramento Solid Waste Services
 2812 Meadowview Road, Building 1
 Sacramento, CA 95832
 Phone: (916) 808-4839 / Fax: (916) 808-4999
 C&D@cityofsacramento.org

This Waste Management Plan (WMP) must be submitted and approved before work can begin. Only one WMP is required for each public construction project. The administration fee and, if applicable, a security deposit must be submitted with this form to be approved. Administration fee is 0.04% of project bid amount (min \$40, max \$800); security deposit is 1% of bid amount (max \$10,000). The accompanying Waste Log must be submitted within 30 days of the project completion report, or a penalty may be imposed.

A. Building Project Information:

Project Bid Amount: \$ _____

Job Address: _____

Contractor: _____ Phone: _____

Address: _____

B. Briefly describe the project:

C. Materials Required to be Recycled. Please check all the recyclables you anticipate will be generated during the project:

Scrap metal items (examples: structural steel, ductwork, gutters, pipes, appliances, fixtures, fencing & railing, sinks, tubs, roofing material);

Inert materials (dirt, soil, rocks, concrete, asphalt paving, brick & block);

Corrugated cardboard (mostly from packaging);

Wooden pallets (whole or broken);

Clean wood waste (unpainted, untreated dimensional lumber and plywood; fasteners OK for recycling);

50% of all All materials debris listed above must be recycled if generated during the course of your project. You can either source-separate them, which may be hauled by anyone, or mix them in one container and send the **mixed C&D debris** load to a **Certified Mixed C&D Sorting Facility**. Mixed C&D loads can only be hauled by a franchised hauler or self-hauled. Please see Section F. Definitions, on the next page, for more information.

D. Material Management

- How will C&D debris will be stored on the project site: Mixed C&D Source-Separated
- Company to haul away debris: _____
- Facilities to receive debris: _____

C&D Debris Waste Management Plan

C&D Debris Waste Management Plan
City of Sacramento Solid Waste Services
2812 Meadowview Road, Building 1
Sacramento, CA 95832
Phone: (916) 808-4839 / Fax: (916) 808-4999
C&D@cityofsacramento.org

E. Definitions.

Please read and understand these terms. Call Solid Waste at (916) 808-4833 if these terms are not clear to you. More information is also available online at <http://www.cityofsacramento.org/utilities/>.

1. **Self-haul or self-hauling:** This is when the general contractor or a subcontractor *who is doing work on the project* hauls their own waste materials for recycling or disposal. Note that a *jobsite cleanup crew is not doing other work on the project and is not self-hauling*. Jobsite cleanup crews need to be franchised in order to haul mixed C&D debris away.
2. **Franchised hauler:** Check the Department of Utilities (DOU) website for a list of these haulers. Only these companies and the City of Sacramento can collect and haul mixed C&D debris generated within the City for a fee.
3. **Source separation:** This means keeping wood, metal, cardboard, or other recyclables in separate containers, and sending the materials to an authorized recycler. A list of authorized recyclers can be found on the DOU web site. Source-separated materials may be hauled by anyone.
4. **Mixed C&D debris:** This means putting all recyclable debris into one container. Mixed materials must be sent to a certified mixed C&D sorting facility. Mixed materials may be either self-hauled or hauled by a franchised hauler. If your job site is crowded, this option saves the most space.
5. **Certified Mixed C&D Sorting Facility:** See the DOU web site for a list. These facilities have been certified by the Sacramento Regional Solid Waste Authority (SWA) to extract recyclable materials from mixed C&D debris.

F. Terms and Conditions

- Your approved Waste Management Plan and Waste Log must be kept on the job site for the duration of the project.
- City of Sacramento Solid Waste Services staff may enter the jobsite to inspect waste collection areas.
- ALL Clean Wood Waste (unpainted, untreated lumber, plywood and OSB), Inert Materials (concrete, asphalt paving, brick, block, and dirt), Wooden Pallets, Scrap Metal, and Corrugated Cardboard must be recycled.
- Only SWA-Certified Mixed C&D Sorting Facilities may be used to recycle these materials if mixed with other materials.
- Only the City of Sacramento, SWA-Franchised Haulers, or self-haulers (as defined above) may collect and transport mixed C&D material from the jobsite.
- C&D Debris may not be burned or dumped illegally.
- Your Waste Log must be completed and submitted, with supporting weight tickets, within 30 days of submitting your project completion report. All waste hauling and disposal or recycling activity must be entered on the Waste Log, including information from any subcontractors who self-hauled their own debris off-site.
- You must keep all receipts or weight-tickets from your project for a period of one year from the submittal of your waste log.
- Failure to comply with these terms and conditions may result in a fine and payment of a security deposit on future projects.

C&D Debris Haulers & Facilities

C&D Debris Waste Management Plan
City of Sacramento Solid Waste Services
2812 Meadowview Road, Building 1
Sacramento, CA 95832
Phone: (916) 808-4833 / Fax: (916) 808-4999
C&D@cityofsacramento.org

Certified Mixed C&D Facilities

Allied Waste / Elder Creek Transfer and Recovery	(916) 387-8425
L&D Landfill	(916) 737-8640
Waste Management / K&M Recycle America	(916) 452-0142

Franchised Haulers

ACES Waste Services, Inc.	(866) 488-8837	Elk Grove Waste Management, LLC	(916) 689-4052
Allied Waste Services	(916) 631-0600	Mini Drops, Inc.	(916) 686-8785
All Waste Systems, Inc.	(916) 456-1555	Norcal Waste Services of Sacramento	(916) 381-5300
Atlas Disposal Industries, LLC	(916) 455-2800	North West Recyclers	(916) 686-8575
California Waste Recovery Systems	(916) 441-1985	Waste Management of Sacramento	(916) 387-1400
Central Valley Waste Services, Inc.	(209) 369-8274	Waste Removal & Recycling	(916) 453-1400
City of Sacramento Solid Waste	(916) 808-4839	Western Strategic Materials, Inc.	(916) 388-1076

Recyclers*		Recovery Stations & Landfills	
Bell Marine	(916) 442-9089	Elder Creek Recovery & Transfer Station	(916) 387-8425
C & C Paper Recycling	(916) 920-2673	Kiefer Landfill	(916) 875-5555
EBI Aggregates	(916) 372-7580	L & D Landfill	(916) 383-9420
International Paper	(916) 371-4634	North Area Recovery Station	(916) 875-5555
Modern Waste Solutions	(916) 447-6800	Sacramento Recycling & Transfer Station	(916) 379-0500
PRIDE Industries, Inc.	(916) 640-1300	Waste Management Recycle America	(916) 452-0142
Recycling Industries, Inc.	(916) 452-3961		
Sacramento Local Conservation Corps	(916) 386-8394		
Smurfit-Stone Container Corporation	(916) 381-3340		
Southside Art Center	(916) 387-8080		
Spencer Building Maintenance, Inc.	(916) 922-1900		

More updated information can be found online at:

<http://www.cityofsacramento.org/utilities/>

* Please note that any facility may receive source-separated recyclable materials as long as it is authorized to do so by the State of California. This is not meant to be a complete list.



DEPARTMENT OF TRANSPORTATION
 ENGINEERING SERVICES DIVISION
 9151 Street, Room 2000
 Sacramento, CA 95814

PAY REQUEST APPLICATION

(All information to be entered on Schedule of Values page.)

PROJECT NAME:	2011 Speed Hump Project		
CONTRACTOR: (per agreement)			
REMITTANCE ADDRESS:			
PHONE NUMBER ()			
INVOICE NO:	S15101200-	CITY PROJECT NUMBER:	S15101200
		PERIOD ENDING DATE:	

ORIGINAL CONTRACT AMOUNT:	
CHANGE ORDER NO. 1	
CHANGE ORDER NO. 2	
CHANGE ORDER NO. 3	
CHANGE ORDER NO. 4	
CHANGE ORDER NO. 5	
CHANGE ORDER NO. 6	
CHANGE ORDER NO. 7	
CHANGE ORDER NO. 8	
CHANGE ORDER NO. 9	
TOTAL CHANGE ORDERS:	
CONTRACT AMOUNT TO DATE:	
TOTAL WORK COMPLETED TO DATE:	
RETENTION WITHHELD:	
LESS PREVIOUS PAYMENTS:	
AMOUNT DUE THIS INVOICE:	
TOTAL COMPLETED LESS RETENTION:	

If the project is CDBG funded, or the prime contractor is a certified UDBE or ESBE, please check the applicable box & you do not need to fill out the section below.

UDBE Prime Contractor
 ESBE Prime Contractor
 CDBG Funded

List all ESBE/UDBE subcontractors employed on this project during this period ending date and indicate committed amounts to be paid to the sub contractors. Please also include ESBE/UDBE materials suppliers and trucking firms. Keep records of payments made, as you will be asked to furnish these at contract completion. The Pay Request Application will be considered incomplete unless this information is provided along with all other required documentation to support the request for payment. Attach additional sheets if necessary.

Circle UDBE for FEDERALLY funded projects.
 Circle ESBE for LOCALLY funded projects.

Original amount pledged:	
Pledge Increase/Decrease to Include Change Order(s):	
Total amount pledged:	

ESBE / UDBE Sub-Contractor	Previous Total (A)	Current Pay Request Total (B)	Total ESBE / UDBE Work (A+B)	Percentage Attained (A+B)/Amount Pledged
Totals:				

Labor compliance (payrolls, etc.) is current and submitted for this Pay Request



DEPARTMENT OF TRANSPORTATION
 ENGINEERING SERVICES DIVISION
 915 "I" Street, Room 2000
 Sacramento, CA 95814

PAY REQUEST APPLICATION

(All information to be entered on Schedule of Values page.)

Approved By (Prime Contractor)	_____ <small>PRINT AND SIGN</small>	Date: _____
Submit To:	Department of Transportation 915 "I" Street, Room 2000 Sacramento, CA 95814 Attn: CONSTRUCTION INSPECTOR	
Approved By (Resident Const. Inspector)	_____ <small>PRINT AND SIGN</small>	Date: _____
Certified by Project Manager By (Project Manager)	_____ <small>PRINT AND SIGN</small>	Date: _____
Approved By (Labor Compliance)	_____ <small>PRINT AND SIGN</small>	Date: _____

In accordance with Public Contract Code Sec. 20104.50 the City shall pay the Contractor interest on any progress payment which is made by City more than 30 days after City receives an undisputed and properly submitted written payment request. Said interest shall be equal to the rate set forth in CCP Sec.685.010(a), and shall begin to accrue upon the expiration of said 30 day period. Any written request for a progress payment which City determines to be disputed, improper or not suitable for payment for any reason shall be returned to Contractor within 7 days after receipt by City, along with a written statement of the reason or reasons why such request is disputed, improper or not suitable for payment.

	Contractor Entered Data
	Construction Inspector's Name.
	PM certifies that all information is correct.



DEPARTMENT OF TRANSPORTATION
ENGINEERING SERVICES DIVISION
915 I Street, Room 2000

SCHEDULE OF VALUES

V3 - 03/29/2011

PROJECT NAME: 2011 Speed Hump Project
 CITY PROJECT NUMBER: S15101200
 CONTRACTOR: (As per City Agreement)
 REMITTANCE ADDRESS:
 PHONE NUMBER: (...)
 INVOICE NUMBER: S15101200-

Remit To:
 Department of Transportation
 Engineering Services Division
 915 I Street, Room 2000
 Sacramento, CA 95814

Payment No. _____
 Work Performed Thru _____
 Days Expended on Contract _____

Item No	Item Description	Original Contract Quantity	Unit	Unit Price	Original Contract Amount	Previous Work Completed (SHOULD MATCH PREVIOUS PAY REQUEST'S TOTAL WORK COMPLETED COLUMNS)		This Estimate		Total Work Completed		Balance of Contract		
						Quantity	Amount	Quantity	Amount	Quantity	Amount	Quantity	Amount	
1	Asphaltic Concrete Speed Lump to Construct													
	S15101200 Speed Hump Program	1,430											1,430.00	
	S15071138 Camellia	118											118.00	
	S15071146 Willow Rancho NTMP	278											278.00	
	S15071147 Visia NTMP	541											541.00	
	S15071148 Village Park NTMP	175											175.00	
	S15071149 Ben Ali	432												
	S15101105 Meadows	679												
2	Asphaltic Concrete Speed Table to Construct													
	S15101200 - Speed Hump Program	120											120.00	
		Original Contract Total:												
Change Order #1 - See change order summary sheet for details														
		Sum of all Change Orders			\$0.00	"Total Work to Date" From Previous Pay Request		This Estimate (current work)		Total Work to Date		Balancing Total of Adjusted Contract		\$0.00
		CCO Adjusted Contract Amount (Original + Change Orders)			\$0.00	Retention Withheld From Previous Pay Request		This Retention (current work) (10%)		Retention Withheld to Date				
		Partial Retention Release (Prior approval is needed before proceeding with partial retention release)				*Retention Released to Date" From Previous Pay Request		Current Retention Release		Retention Released to Date				
						"Total Paid To Date" from Previous Pay Request		This Payment		Total Paid to Date				
												Supervisor Approval (Print & Sign)		

Contractor Entered Data



Department of
General Services
 BUILDING GREEN BUYING GREEN WORKING GREEN

RML PAVING - #44805

SUPPLIER PROFILE			
Legal Business Name	RML PAVING		
Doing Business As	RML PAVING		
Address	7431 PEACOCK WAY SACRAMENTO, CA 95820	Phone	(916) 215-2070
		FAX	(916) 381-1054
Email	rmlpaving@sbcglobal.net		
Business Types	Construction		
Service Areas	Alameda, Butte, Colusa, Contra Costa, El Dorado, Glenn, Madera, Marin, Merced, Napa, Nevada, Placer, Sacramento, San Joaquin, San Mateo, Santa Clara, Sierra, Solano, Sonoma, Stanislaus, Sutter, Yolo, Yuba,		
Keywords	ADA UPGRADES SPECIALIST CONCRETE REPAIRS ASPHALT PARKING LOT REPAIRS MAINTENANCE STRIPING OVERLAYS PARKING BUMPERS SPEED BUMPS CRACK FILL		
Construction License Types	C-12 - Excavation work and paving		
Classifications	721527 - Concrete installation and repair services		

Active Certifications

TYPE	STATUS	FROM	TO
SB (Micro)	Approved	Mar 2, 2010	Mar 31, 2012

Certification History

TYPE	STATUS	FROM	TO
SB (Micro)	Expired	Mar 11, 2008	Oct 31, 2009
SB	Expired	Feb 23, 2007	Mar 31, 2008



CERTIFICATE OF LIABILITY INSURANCE

OP ID: RW

DATE (MM/DD/YYYY)

09/14/11

THIS CERTIFICATE IS ISSUED AS A MATTER OF INFORMATION ONLY AND CONFERS NO RIGHTS UPON THE CERTIFICATE HOLDER. THIS CERTIFICATE DOES NOT AFFIRMATIVELY OR NEGATIVELY AMEND, EXTEND OR ALTER THE COVERAGE AFFORDED BY THE POLICIES BELOW. THIS CERTIFICATE OF INSURANCE DOES NOT CONSTITUTE A CONTRACT BETWEEN THE ISSUING INSURER(S), AUTHORIZED REPRESENTATIVE OR PRODUCER, AND THE CERTIFICATE HOLDER.

IMPORTANT: If the certificate holder is an ADDITIONAL INSURED, the policy(ies) must be endorsed. If SUBROGATION IS WAIVED, subject to the terms and conditions of the policy, certain policies may require an endorsement. A statement on this certificate does not confer rights to the certificate holder in lieu of such endorsement(s).

PRODUCER Roberts & Phillips Insurance Services, Inc. 1430 22nd Street Sacramento, CA 95816 Wendy Brown	916-326-4600 916-440-9794	CONTACT NAME: PHONE (A/C, No, Ext): FAX (A/C, No): E-MAIL ADDRESS: PRODUCER CUSTOMER ID #: RMLPA-2
	INSURED RML Paving Rodolfo Martinez 7431 Peacock Way Sacramento, CA 95820	
		INSURER(S) AFFORDING COVERAGE
		INSURER A: Navigators Insurance Company
		INSURER B:
		INSURER C:
		INSURER D:
		INSURER E:
		INSURER F:
		NAIC # 42307

COVERAGES **CERTIFICATE NUMBER:** **REVISION NUMBER:**

THIS IS TO CERTIFY THAT THE POLICIES OF INSURANCE LISTED BELOW HAVE BEEN ISSUED TO THE INSURED NAMED ABOVE FOR THE POLICY PERIOD INDICATED. NOTWITHSTANDING ANY REQUIREMENT, TERM OR CONDITION OF ANY CONTRACT OR OTHER DOCUMENT WITH RESPECT TO WHICH THIS CERTIFICATE MAY BE ISSUED OR MAY PERTAIN, THE INSURANCE AFFORDED BY THE POLICIES DESCRIBED HEREIN IS SUBJECT TO ALL THE TERMS, EXCLUSIONS AND CONDITIONS OF SUCH POLICIES. LIMITS SHOWN MAY HAVE BEEN REDUCED BY PAID CLAIMS.

INSR LTR	TYPE OF INSURANCE	ADDL INSR	SUBR WVD	POLICY NUMBER	POLICY EFF (MM/DD/YYYY)	POLICY EXP (MM/DD/YYYY)	LIMITS
A	GENERAL LIABILITY <input checked="" type="checkbox"/> COMMERCIAL GENERAL LIABILITY <input type="checkbox"/> CLAIMS-MADE <input checked="" type="checkbox"/> OCCUR	X		0410130181	11/12/10	11/12/11	EACH OCCURRENCE \$ 1,000,000 DAMAGE TO RENTED PREMISES (Ea occurrence) \$ 50,000 MED EXP (Any one person) \$ 5,000 PERSONAL & ADV INJURY \$ 1,000,000 GENERAL AGGREGATE \$ 2,000,000 PRODUCTS - COMP/OP AGG \$ 2,000,000
	GEN'L AGGREGATE LIMIT APPLIES PER: <input type="checkbox"/> POLICY <input type="checkbox"/> PRO-JECT <input type="checkbox"/> LOC						
	AUTOMOBILE LIABILITY <input type="checkbox"/> ANY AUTO <input type="checkbox"/> ALL OWNED AUTOS <input type="checkbox"/> SCHEDULED AUTOS <input type="checkbox"/> HIRED AUTOS <input type="checkbox"/> NON-OWNED AUTOS						COMBINED SINGLE LIMIT (Ea accident) \$ BODILY INJURY (Per person) \$ BODILY INJURY (Per accident) \$ PROPERTY DAMAGE (Per accident) \$ \$ \$
	<input type="checkbox"/> UMBRELLA LIAB <input type="checkbox"/> EXCESS LIAB <input type="checkbox"/> DEDUCTIBLE <input type="checkbox"/> RETENTION \$						EACH OCCURRENCE \$ AGGREGATE \$ \$ \$
	WORKERS COMPENSATION AND EMPLOYERS' LIABILITY ANY PROPRIETOR/PARTNER/EXECUTIVE OFFICER/MEMBER EXCLUDED? (Mandatory in NH) If yes, describe under DESCRIPTION OF OPERATIONS below		N/A				<input type="checkbox"/> WC STATU-TORY LIMITS <input type="checkbox"/> OTH-ER E.L. EACH ACCIDENT \$ E.L. DISEASE - EA EMPLOYEE \$ E.L. DISEASE - POLICY LIMIT \$

DESCRIPTION OF OPERATIONS / LOCATIONS / VEHICLES (Attach ACORD 101, Additional Remarks Schedule, if more space is required)
 Certificate holder is named as additional insured per attached endorsement.
 Ten days notice of cancellation for non-payment of premium, Thirty days all other.

CERTIFICATE HOLDER City of Sacramento 915 I Street, Room 2000 Sacramento, CA 95841	CITY OF S	CANCELLATION SHOULD ANY OF THE ABOVE DESCRIBED POLICIES BE CANCELLED BEFORE THE EXPIRATION DATE THEREOF, NOTICE WILL BE DELIVERED IN ACCORDANCE WITH THE POLICY PROVISIONS. AUTHORIZED REPRESENTATIVE
--	------------------	--

© 1988-2009 ACORD CORPORATION. All rights reserved.

ACORD CERTIFICATE OF LIABILITY INSURANCE		OP ID SM LUNROD1	DATE (MM/DD/YYYY) 09/13/11
PRODUCER Western Truck Insurance Servic Lic #0B02562 11950 Aviation Blvd Irwood CA 90304 Phone: 310-215-2920 Fax: 310-215-2915		THIS CERTIFICATE IS ISSUED AS A MATTER OF INFORMATION ONLY AND CONFERS NO RIGHTS UPON THE CERTIFICATE HOLDER. THIS CERTIFICATE DOES NOT AMEND, EXTEND OR ALTER THE COVERAGE AFFORDED BY THE POLICIES BELOW.	
INSURED RML Paving Rodolfo M Luna 7431 Peacock Way Sacramento CA 95820		INSURERS AFFORDING COVERAGE	NAIC #
		INSURER A: Progressive Casualty	24260
		INSURER B:	
		INSURER C:	
		INSURER D:	
		INSURER E:	

COVERAGES

THE POLICIES OF INSURANCE LISTED BELOW HAVE BEEN ISSUED TO THE INSURED NAMED ABOVE FOR THE POLICY PERIOD INDICATED. NOTWITHSTANDING ANY REQUIREMENT, TERM OR CONDITION OF ANY CONTRACT OR OTHER DOCUMENT WITH RESPECT TO WHICH THIS CERTIFICATE MAY BE ISSUED OR MAY PERTAIN, THE INSURANCE AFFORDED BY THE POLICIES DESCRIBED HEREIN IS SUBJECT TO ALL THE TERMS, EXCLUSIONS AND CONDITIONS OF SUCH POLICIES. AGGREGATE LIMITS SHOWN MAY HAVE BEEN REDUCED BY PAID CLAIMS.

INSR ADD'L LTR	INSRD	TYPE OF INSURANCE	POLICY NUMBER	POLICY EFFECTIVE DATE (MM/DD/YY)	POLICY EXPIRATION DATE (MM/DD/YY)	LIMITS	
		GENERAL LIABILITY <input type="checkbox"/> COMMERCIAL GENERAL LIABILITY <input type="checkbox"/> CLAIMS MADE <input type="checkbox"/> OCCUR GENL AGGREGATE LIMIT APPLIES PER: <input type="checkbox"/> POLICY <input type="checkbox"/> PROJEC <input type="checkbox"/> LOC				EACH OCCURRENCE	\$
						DAMAGE TO RENTED PREMISES (Ea occurrence)	\$
						MED EXP (Any one person)	\$
						PERSONAL & ADV INJURY	\$
						GENERAL AGGREGATE	\$
						PRODUCTS - COMP/OP AGG	\$
A		AUTOMOBILE LIABILITY <input type="checkbox"/> ANY AUTO <input type="checkbox"/> ALL OWNED AUTOS <input checked="" type="checkbox"/> SCHEDULED AUTOS <input type="checkbox"/> HIRED AUTOS <input type="checkbox"/> NON-OWNED AUTOS	06117584-3	12/20/10	12/20/11	COMBINED SINGLE LIMIT (Ea accident)	\$ 1,000,000
						BODILY INJURY (Per person)	\$
						BODILY INJURY (Per accident)	\$
						PROPERTY DAMAGE (Per accident)	\$
		GARAGE LIABILITY <input type="checkbox"/> ANY AUTO				AUTO ONLY - EA ACCIDENT	\$
						OTHER THAN AUTO ONLY: EA ACC	\$
						AGG	\$
		EXCESS/UMBRELLA LIABILITY <input type="checkbox"/> OCCUR <input type="checkbox"/> CLAIMS MADE <input type="checkbox"/> DEDUCTIBLE <input type="checkbox"/> RETENTION \$				EACH OCCURRENCE	\$
						AGGREGATE	\$
							\$
							\$
		WORKERS COMPENSATION AND EMPLOYERS' LIABILITY ANY PROPRIETOR/PARTNER/EXECUTIVE OFFICER/MEMBER EXCLUDED? If yes, describe under SPECIAL PROVISIONS below				WC STATUTORY LIMITS	OTHER
						E.L. EACH ACCIDENT	\$
						E.L. DISEASE - EA EMPLOYEE	\$
						E.L. DISEASE - POLICY LIMIT	\$
A		OTHER Physical Damage	06117584-3	12/20/10	12/20/11	Lsp/Coll	\$1000 Ded.

DESCRIPTION OF OPERATIONS / LOCATIONS / VEHICLES / EXCLUSIONS ADDED BY ENDORSEMENT / SPECIAL PROVISIONS
 1994 Ford F350 Super Duty Pickup Vin: A36451. Certificate holder is named Additional insured. Endorsement to follow from Auto Liability Carrier.

CERTIFICATE HOLDER City of Sacramento Department of Transportation Engineering Services Div 915 I Street Room 2000 Sacramento CA 95814	CANCELLATION SHOULD ANY OF THE ABOVE DESCRIBED POLICIES BE CANCELLED BEFORE THE EXPIRATION DATE THEREOF, THE ISSUING INSURER WILL ENDEAVOR TO MAIL 30 DAYS WRITTEN NOTICE TO THE CERTIFICATE HOLDER NAMED TO THE LEFT, BUT FAILURE TO DO SO SHALL IMPOSE NO OBLIGATION OR LIABILITY OF ANY KIND UPON THE INSURER, ITS AGENTS OR REPRESENTATIVES. AUTHORIZED REPRESENTATIVE Coml Transportation Ins Svcs
--	---

BLANKET ADDITIONAL INSUREDS— OWNERS, LESSEES OR CONTRACTORS

This endorsement modifies insurance provided under the following:

COMMERCIAL GENERAL LIABILITY COVERAGE PART
SCHEDULE

Policy Number: 04-10130181	Endorsement Effective: 11/12/10 12:01 a.m.
Named Insured RODOLFO MARTINEZ LUNA	Countersigned By: <i>Lisa Erickson</i>

SCHEDULE

Name of Person or Organization: Any person or organization that the named insured is obligated by virtue of a written contract or agreement to provide insurance such as is afforded by this policy.
Location:

(If no entry appears above, information required to complete this endorsement will be shown in the Declarations as applicable to this endorsement.)

A. Section II – Who Is An Insured is amended to include as an insured the person or organization shown in the Schedule, but only to the extent that the person or organization shown in the Schedule is held liable for your acts or omissions arising out of your ongoing operations performed for that insured.

B. With respect to the insurance afforded to these additional insureds, the following exclusion is added:

2. Exclusions

This insurance does not apply to "bodily injury" or "property damage" occurring after:

- (1) All work, including materials, parts or equipment furnished in connection with such work, on the project (other than service, maintenance or repairs) to be performed by or on behalf of the additional insured(s) at the site of the covered operations has been completed; or
- (2) That portion of "your work" out of which the injury or damage arises has been put to its intended use by any person or organization other than another contractor or subcontractor engaged in performing operations for a principal as a part of the same project.

C. The words "you" and "your" refer to the Named Insured shown in the Declarations.

D. "Your work" means work or operations performed by you or on your behalf, and materials, parts or equipment furnished in connection with such work or operations.

Primary Wording

If required by written contract or agreement: Such insurance as is afforded by this policy shall be primary insurance, and any insurance or self-insurance maintained by the above additional insured(s) shall be excess of the insurance afforded to the named insured and shall not contribute to it.

Waiver of Subrogation

If required by written contract or agreement: We waive any right of recovery we may have against an entity that is an additional insured per the terms of this endorsement because of payments we make for injury or damage arising out of "your work" done under a contract with that person or organization.



P.O. BOX 420807, SAN FRANCISCO, CA 94142-0807

CERTIFICATE OF WORKERS' COMPENSATION INSURANCE

ISSUE DATE: 09-13-2011

GROUP:
POLICY NUMBER: 1808537-2010
CERTIFICATE ID: 108
CERTIFICATE EXPIRES: 11-01-2011
11-01-2010/11-01-2011
THIS CERTIFICATE SUPERSEDES AND CORRECTS
CERTIFICATE # 106 DATED 09-13-2011

CITY OF SACRAMENTO
DEPT OF TRANSPORTATION
915 I ST
SACRAMENTO CA 95814-2604

NF

This is to certify that we have issued a valid Workers' Compensation insurance policy in a form approved by the California Insurance Commissioner to the employer named below for the policy period indicated.

This policy is not subject to cancellation by the Fund except upon 30 days advance written notice to the employer.

We will also give you 30 days advance notice should this policy be cancelled prior to its normal expiration.

This certificate of insurance is not an insurance policy and does not amend, extend or alter the coverage afforded by the policy listed herein. Notwithstanding any requirement, term or condition of any contract or other document with respect to which this certificate of insurance may be issued or to which it may pertain, the insurance afforded by the policy described herein is subject to all the terms, exclusions, and conditions, of such policy.

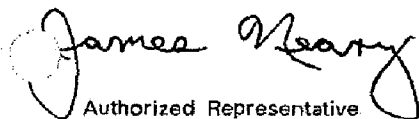
Authorized Representative

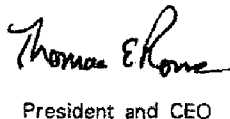
President and CEO

UNLESS INDICATED OTHERWISE BY ENDORSEMENT, COVERAGE UNDER THIS POLICY EXCLUDES THE FOLLOWING: THOSE NAMED IN THE POLICY DECLARATIONS AS AN INDIVIDUAL EMPLOYER OR A HUSBAND AND WIFE EMPLOYER; EMPLOYEES COVERED ON A COMPREHENSIVE PERSONAL LIABILITY INSURANCE POLICY ALSO AFFORDING CALIFORNIA WORKERS' COMPENSATION BENEFITS; EMPLOYEES EXCLUDED UNDER CALIFORNIA WORKERS' COMPENSATION LAW.

EMPLOYER'S LIABILITY LIMIT INCLUDING DEFENSE COSTS: \$1,000,000 PER OCCURRENCE.

ENDORSEMENT #2065 ENTITLED CERTIFICATE HOLDERS' NOTICE EFFECTIVE 11-01-2005 IS ATTACHED TO AND FORMS A PART OF THIS POLICY.

ENDORSEMENT #2570 ENTITLED WAIVER OF SUBROGATION EFFECTIVE 2011-09-13 IS ATTACHED TO AND FORMS A PART OF THIS POLICY. THIRD PARTY NAME:
CITY OF SACRAMENTO

EMPLOYER

MARTINEZ, RODOLFO DBA: RML PAVING
7431 PEACOCK WAY
SACRAMENTO CA 95820

NF

[CES,CN]

PRINTED : 09-13-2011

ACORD CERTIFICATE OF LIABILITY INSURANCE

OP ID SM
LUNROD1

DATE (MM/DD/YYYY)
09/13/11

PRODUCER
Western Truck Insurance Servic
Lic #0B02562
11950 Aviation Blvd
Woodland CA 90304
Phone: 310-215-2920 Fax: 310-215-2915

INSURED
RML Paving
Rodolfo M Luna
7431 Peacock Way
Sacramento CA 95820

THIS CERTIFICATE IS ISSUED AS A MATTER OF INFORMATION ONLY AND CONFERS NO RIGHTS UPON THE CERTIFICATE HOLDER. THIS CERTIFICATE DOES NOT AMEND, EXTEND OR ALTER THE COVERAGE AFFORDED BY THE POLICIES BELOW.

INSURERS AFFORDING COVERAGE		NAIC #
INSURER A:	Progressive Casualty	24260
INSURER B:		
INSURER C:		
INSURER D:		
INSURER E:		

COVERAGES

THE POLICIES OF INSURANCE LISTED BELOW HAVE BEEN ISSUED TO THE INSURED NAMED ABOVE FOR THE POLICY PERIOD INDICATED, NOTWITHSTANDING ANY REQUIREMENT, TERM OR CONDITION OF ANY CONTRACT OR OTHER DOCUMENT WITH RESPECT TO WHICH THIS CERTIFICATE MAY BE ISSUED OR MAY PERTAIN, THE INSURANCE AFFORDED BY THE POLICIES DESCRIBED HEREIN IS SUBJECT TO ALL THE TERMS, EXCLUSIONS AND CONDITIONS OF SUCH POLICIES. AGGREGATE LIMITS SHOWN MAY HAVE BEEN REDUCED BY PAID CLAIMS.

INSR ADD'L LTR	INSRD	TYPE OF INSURANCE	POLICY NUMBER	POLICY EFFECTIVE DATE (MM/DD/YY)	POLICY EXPIRATION DATE (MM/DD/YY)	LIMITS	
		GENERAL LIABILITY <input type="checkbox"/> COMMERCIAL GENERAL LIABILITY <input type="checkbox"/> CLAIMS MADE <input type="checkbox"/> OCCUR GEN'L AGGREGATE LIMIT APPLIES PER: <input type="checkbox"/> POLICY <input type="checkbox"/> PRO-JECT <input type="checkbox"/> LOC				EACH OCCURRENCE	\$
						DAMAGE TO RENTED PREMISES (Ea occurrence)	\$
						MED EXP (Any one person)	\$
						PERSONAL & ADV INJURY	\$
						GENERAL AGGREGATE	\$
						PRODUCTS - COMP/OP AGG	\$
A		AUTOMOBILE LIABILITY <input type="checkbox"/> ANY AUTO <input checked="" type="checkbox"/> ALL OWNED AUTOS <input checked="" type="checkbox"/> SCHEDULED AUTOS <input type="checkbox"/> HIRED AUTOS <input type="checkbox"/> NON-OWNED AUTOS	06117584-3	12/20/10	12/20/11	COMBINED SINGLE LIMIT (Ea accident)	\$ 1,000,000
						BODILY INJURY (Per person)	\$
						BODILY INJURY (Per accident)	\$
						PROPERTY DAMAGE (Per accident)	\$
		GARAGE LIABILITY <input type="checkbox"/> ANY AUTO				AUTO ONLY - EA ACCIDENT	\$
						OTHER THAN AUTO ONLY: EA ACC	\$
						AGG	\$
		EXCESS/UMBRELLA LIABILITY <input type="checkbox"/> OCCUR <input type="checkbox"/> CLAIMS MADE DEDUCTIBLE RETENTION \$				EACH OCCURRENCE	\$
						AGGREGATE	\$
							\$
							\$
		WORKERS COMPENSATION AND EMPLOYERS' LIABILITY ANY PROPRIETOR/PARTNER/EXECUTIVE OFFICER/MEMBER EXCLUDED? If yes, describe under SPECIAL PROVISIONS below				WC STATUTORY LIMITS	OTHER
						E.L. EACH ACCIDENT	\$
						E.L. DISEASE - EA EMPLOYEE	\$
						E.L. DISEASE - POLICY LIMIT	\$
A		Physical Damage	06117584-3	12/20/10	12/20/11	Isp/Coll	\$1000 Ded.

DESCRIPTION OF OPERATIONS / LOCATIONS / VEHICLES / EXCLUSIONS ADDED BY ENDORSEMENT / SPECIAL PROVISIONS
 1994 Ford F350 Super Duty Pickup Vin: A36451. Certificate holder is named Additional insured. Endorsement to follow from Auto Liability Carrier.

CERTIFICATE HOLDER	CANCELLATION
CITYSAC City of Sacramento Department of Transportation Engineering Services Div 915 I Street Room 2000 Sacramento CA 95814	SHOULD ANY OF THE ABOVE DESCRIBED POLICIES BE CANCELLED BEFORE THE EXPIRATION DATE THEREOF, THE ISSUING INSURER WILL ENDEAVOR TO MAIL 30 DAYS WRITTEN NOTICE TO THE CERTIFICATE HOLDER NAMED TO THE LEFT, BUT FAILURE TO DO SO SHALL IMPOSE NO OBLIGATION OR LIABILITY OF ANY KIND UPON THE INSURER, ITS AGENTS OR REPRESENTATIVES. AUTHORIZED REPRESENTATIVE Coml Transportation Ins Svcs

ACORD CERTIFICATE OF LIABILITY INSURANCE		OP ID SM LUNROD1	DATE (MM/DD/YYYY) 09/21/11
PRODUCER Western Truck Insurance Servic Lic #0B02562 150 Aviation Blvd glewood CA 90304 Phone: 310-215-2920 Fax: 310-215-2915		THIS CERTIFICATE IS ISSUED AS A MATTER OF INFORMATION ONLY AND CONFERS NO RIGHTS UPON THE CERTIFICATE HOLDER. THIS CERTIFICATE DOES NOT AMEND, EXTEND OR ALTER THE COVERAGE AFFORDED BY THE POLICIES BELOW.	
INSURED RML Paving Rodolfo M Luna 7431 Peacock Way Sacramento CA 95820		INSURERS AFFORDING COVERAGE	NAIC #
		INSURER A: Progressive Casualty	24260
		INSURER B:	
		INSURER C:	
		INSURER D:	
		INSURER E:	

COVERAGES

THE POLICIES OF INSURANCE LISTED BELOW HAVE BEEN ISSUED TO THE INSURED NAMED ABOVE FOR THE POLICY PERIOD INDICATED. NOTWITHSTANDING ANY REQUIREMENT, TERM OR CONDITION OF ANY CONTRACT OR OTHER DOCUMENT WITH RESPECT TO WHICH THIS CERTIFICATE MAY BE ISSUED OR MAY PERTAIN, THE INSURANCE AFFORDED BY THE POLICIES DESCRIBED HEREIN IS SUBJECT TO ALL THE TERMS, EXCLUSIONS AND CONDITIONS OF SUCH POLICIES. AGGREGATE LIMITS SHOWN MAY HAVE BEEN REDUCED BY PAID CLAIMS.

INSR ADD'L LTR INSR	TYPE OF INSURANCE	POLICY NUMBER	POLICY EFFECTIVE DATE (MM/DD/YY)	POLICY EXPIRATION DATE (MM/DD/YY)	LIMITS
	GENERAL LIABILITY <input type="checkbox"/> COMMERCIAL GENERAL LIABILITY <input type="checkbox"/> CLAIMS MADE <input type="checkbox"/> OCCUR GEN'L AGGREGATE LIMIT APPLIES PER: <input type="checkbox"/> POLICY <input type="checkbox"/> PRO-JECT <input type="checkbox"/> LOC				EACH OCCURRENCE \$ DAMAGE TO RENTED PREMISES (Ea occurrence) \$ MED EXP (Any one person) \$ PERSONAL & ADV INJURY \$ GENERAL AGGREGATE \$ PRODUCTS - COMP/OP AGG \$
A	AUTOMOBILE LIABILITY <input type="checkbox"/> ANY AUTO <input checked="" type="checkbox"/> ALL OWNED AUTOS <input checked="" type="checkbox"/> SCHEDULED AUTOS <input type="checkbox"/> HIRED AUTOS <input type="checkbox"/> NON-OWNED AUTOS	06117584-3	12/20/10	12/20/11	COMBINED SINGLE LIMIT (Ea accident) \$1,000,000 BODILY INJURY (Per person) \$ BODILY INJURY (Per accident) \$ PROPERTY DAMAGE (Per accident) \$
	GARAGE LIABILITY <input type="checkbox"/> ANY AUTO				AUTO ONLY - EA ACCIDENT \$ OTHER THAN EA ACC \$ AUTO ONLY: AGG \$
	EXCESS/UMBRELLA LIABILITY <input type="checkbox"/> OCCUR <input type="checkbox"/> CLAIMS MADE DEDUCTIBLE \$ RETENTION \$				EACH OCCURRENCE \$ AGGREGATE \$ \$ \$
	WORKERS COMPENSATION AND EMPLOYERS' LIABILITY ANY PROPRIETOR/PARTNER/EXECUTIVE OFFICER/MEMBER EXCLUDED? If yes, describe under SPECIAL PROVISIONS below				WC STATU-TORY LIMITS OTH-ER \$ E.L. EACH ACCIDENT \$ E.L. DISEASE - EA EMPLOYEE \$ E.L. DISEASE - POLICY LIMIT \$
A	OTHER Physical Damage	06117584-3	12/20/10	12/20/11	Lsp/Coll \$1000 Ded.

DESCRIPTION OF OPERATIONS / LOCATIONS / VEHICLES / EXCLUSIONS ADDED BY ENDORSEMENT / SPECIAL PROVISIONS

1994 Ford F350 Super Duty Pickup Vin: A36451. City of Sacramento its employees, officers and agents are named as additional insured with respect to Auto Liability Policy. PROJECT NUMBER: PN: S15101200. Endorsement attached.

CERTIFICATE HOLDER
CANCELLATION

City of Sacramento Department of Transportation Engineering Services Div 915 I Street Room 2000 Sacramento CA 95814	CITYSAC SHOULD ANY OF THE ABOVE DESCRIBED POLICIES BE CANCELLED BEFORE THE EXPIRATION DATE THEREOF, THE ISSUING INSURER WILL ENDEAVOR TO MAIL 30 DAYS WRITTEN NOTICE TO THE CERTIFICATE HOLDER NAMED TO THE LEFT, BUT FAILURE TO DO SO SHALL IMPOSE NO OBLIGATION OR LIABILITY OF ANY KIND UPON THE INSURER, ITS AGENTS OR REPRESENTATIVES. AUTHORIZED REPRESENTATIVE Coml Transportation Ins Svcs
---	---

Additional insured endorsement

Name of Person or Organization

NAME: CITY OF SACRAMENTO DEPT OF TRANSPORTATION
STREET: 915 I ST 2000
CITY: SACRAMENTO
STATE: CA
ZIP: 95814
JOB #: PN, S15101200

The person or organization named above is an **insured** with respect to such liability coverage as is afforded by the policy but this insurance applies to said **insured** only as a person liable for the conduct of another **insured** and then only to the extent of that liability. We also agree with you that insurance provided by this endorsement will be primary for any power unit specifically described on the **Declarations Page**.

Limit of Liability

Bodily Injury		each person/ each accident
Property Damage		each accident
Combined Liability	1,000,000	each accident

All other terms, limits and provisions of this policy remain unchanged.

This endorsement applies to Policy Number: 06117584-3

Issued to (Name of Insured): RODOLFO LUNA DBA: RML PAVING

Effective date of endorsement: 12/20/2010 Policy expiration date: 12/20/2011

Request for Taxpayer Identification Number and Certification

Give form to the
requester. Do not
send to the IRS.

Print or type
See Specific Instructions on page 2.

Name (as shown on your income tax return) Rodolfo Martinez Luna	
Business name, if different from above R M L Paving	
Check appropriate box: <input checked="" type="checkbox"/> Individual/Sole proprietor <input type="checkbox"/> Corporation <input type="checkbox"/> Partnership <input type="checkbox"/> Limited liability company. Enter the tax classification (D=disregarded entity, C=corporation, P=partnership) ▶ <input type="checkbox"/> Exempt payee <input type="checkbox"/> Other (see instructions) ▶	
Address (number, street, and apt. or suite no.) 7431 peacock way	Requester's name and address (optional)
City, state, and ZIP code sacramento ca 95820	
List account number(s) here (optional)	

Part I Taxpayer Identification Number (TIN)

Enter your TIN in the appropriate box. The TIN provided must match the name given on Line 1 to avoid backup withholding. For individuals, this is your social security number (SSN). However, for a resident alien, sole proprietor, or disregarded entity, see the Part I instructions on page 3. For other entities, it is your employer identification number (EIN). If you do not have a number, see *How to get a TIN* on page 3.

Social security number		
605	14	1900

OR

Employer identification number	
51	0524897

Note. If the account is in more than one name, see the chart on page 4 for guidelines on whose number to enter.

Part II Certification

Under penalties of perjury, I certify that:

1. The number shown on this form is my correct taxpayer identification number (or I am waiting for a number to be issued to me), and
2. I am not subject to backup withholding because: (a) I am exempt from backup withholding, or (b) I have not been notified by the Internal Revenue Service (IRS) that I am subject to backup withholding as a result of a failure to report all interest or dividends, or (c) the IRS has notified me that I am no longer subject to backup withholding, and
3. I am a U.S. citizen or other U.S. person (defined below).

Certification instructions. You must cross out item 2 above if you have been notified by the IRS that you are currently subject to backup withholding because you have failed to report all interest and dividends on your tax return. For real estate transactions, item 2 does not apply. For mortgage interest paid, acquisition or abandonment of secured property, cancellation of debt, contributions to an individual retirement arrangement (IRA), and generally, payments other than interest and dividends, you are not required to sign the Certification, but you must provide your correct TIN. See the instructions on page 4.

Sign Here	Signature of U.S. person ▶	Date ▶ <u>9/20/2011</u>
------------------	----------------------------	-------------------------

General Instructions

Section references are to the Internal Revenue Code unless otherwise noted.

Purpose of Form

A person who is required to file an information return with the IRS must obtain your correct taxpayer identification number (TIN) to report, for example, income paid to you, real estate transactions, mortgage interest you paid, acquisition or abandonment of secured property, cancellation of debt, or contributions you made to an IRA.

Use Form W-9 only if you are a U.S. person (including a resident alien), to provide your correct TIN to the person requesting it (the requester) and, when applicable, to:

1. Certify that the TIN you are giving is correct (or you are waiting for a number to be issued),
2. Certify that you are not subject to backup withholding, or
3. Claim exemption from backup withholding if you are a U.S. exempt payee. If applicable, you are also certifying that as a U.S. person, your allocable share of any partnership income from a U.S. trade or business is not subject to the withholding tax on foreign partners' share of effectively connected income.

Note. If a requester gives you a form other than Form W-9 to request your TIN, you must use the requester's form if it is substantially similar to this Form W-9.

Definition of a U.S. person. For federal tax purposes, you are considered a U.S. person if you are:

- An individual who is a U.S. citizen or U.S. resident alien,
- A partnership, corporation, company, or association created or organized in the United States or under the laws of the United States,
- An estate (other than a foreign estate), or
- A domestic trust (as defined in Regulations section 301.7701-7).

Special rules for partnerships. Partnerships that conduct a trade or business in the United States are generally required to pay a withholding tax on any foreign partners' share of income from such business. Further, in certain cases where a Form W-9 has not been received, a partnership is required to presume that a partner is a foreign person, and pay the withholding tax. Therefore, if you are a U.S. person that is a partner in a partnership conducting a trade or business in the United States, provide Form W-9 to the partnership to establish your U.S. status and avoid withholding on your share of partnership income.

The person who gives Form W-9 to the partnership for purposes of establishing its U.S. status and avoiding withholding on its allocable share of net income from the partnership conducting a trade or business in the United States is in the following cases:

- The U.S. owner of a disregarded entity and not the entity,

- The U.S. grantor or other owner of a grantor trust and not the trust, and
- The U.S. trust (other than a grantor trust) and not the beneficiaries of the trust.

Foreign person. If you are a foreign person, do not use Form W-9. Instead, use the appropriate Form W-8 (see Publication 515, *Withholding of Tax on Nonresident Aliens and Foreign Entities*).

Nonresident alien who becomes a resident alien. Generally, only a nonresident alien individual may use the terms of a tax treaty to reduce or eliminate U.S. tax on certain types of income. However, most tax treaties contain a provision known as a "saving clause." Exceptions specified in the saving clause may permit an exemption from tax to continue for certain types of income even after the payee has otherwise become a U.S. resident alien for tax purposes.

If you are a U.S. resident alien who is relying on an exemption contained in the saving clause of a tax treaty to claim an exemption from U.S. tax on certain types of income, you must attach a statement to Form W-9 that specifies the following five items:

1. The treaty country. Generally, this must be the same treaty under which you claimed exemption from tax as a nonresident alien.
2. The treaty article addressing the income.
3. The article number (or location) in the tax treaty that contains the saving clause and its exceptions.
4. The type and amount of income that qualifies for the exemption from tax.
5. Sufficient facts to justify the exemption from tax under the terms of the treaty article.

Example. Article 20 of the U.S.-China income tax treaty allows an exemption from tax for scholarship income received by a Chinese student temporarily present in the United States. Under U.S. law, this student will become a resident alien for tax purposes if his or her stay in the United States exceeds 5 calendar years. However, paragraph 2 of the first Protocol to the U.S.-China treaty (dated April 30, 1984) allows the provisions of Article 20 to continue to apply even after the Chinese student becomes a resident alien of the United States. A Chinese student who qualifies for this exception (under paragraph 2 of the first protocol) and is relying on this exception to claim an exemption from tax on his or her scholarship or fellowship income would attach to Form W-9 a statement that includes the information described above to support that exemption.

If you are a nonresident alien or a foreign entity not subject to backup withholding, give the requester the appropriate completed Form W-8.

What is backup withholding? Persons making certain payments to you must under certain conditions withhold and pay to the IRS 28% of such payments. This is called "backup withholding." Payments that may be subject to backup withholding include interest, tax-exempt interest, dividends, broker and barter exchange transactions, rents, royalties, nonemployee pay, and certain payments from fishing boat operators. Real estate transactions are not subject to backup withholding.

You will not be subject to backup withholding on payments you receive if you give the requester your correct TIN, make the proper certifications, and report all your taxable interest and dividends on your tax return.

Payments you receive will be subject to backup withholding if:

1. You do not furnish your TIN to the requester,
2. You do not certify your TIN when required (see the Part II instructions on page 3 for details),
3. The IRS tells the requester that you furnished an incorrect TIN,

4. The IRS tells you that you are subject to backup withholding because you did not report all your interest and dividends on your tax return (for reportable interest and dividends only), or

5. You do not certify to the requester that you are not subject to backup withholding under 4 above (for reportable interest and dividend accounts opened after 1983 only).

Certain payees and payments are exempt from backup withholding. See the instructions below and the separate instructions for the Requester of Form W-9.

Also see *Special rules for partnerships* on page 1.

Penalties

Failure to furnish TIN. If you fail to furnish your correct TIN to a requester, you are subject to a penalty of \$50 for each such failure unless your failure is due to reasonable cause and not to willful neglect.

Civil penalty for false information with respect to withholding. If you make a false statement with no reasonable basis that results in no backup withholding, you are subject to a \$500 penalty.

Criminal penalty for falsifying information. Willfully falsifying certifications or affirmations may subject you to criminal penalties including fines and/or imprisonment.

Misuse of TINs. If the requester discloses or uses TINs in violation of federal law, the requester may be subject to civil and criminal penalties.

Specific Instructions

Name

If you are an individual, you must generally enter the name shown on your income tax return. However, if you have changed your last name, for instance, due to marriage without informing the Social Security Administration of the name change, enter your first name, the last name shown on your social security card, and your new last name.

If the account is in joint names, list first, and then circle, the name of the person or entity whose number you entered in Part I of the form.

Sole proprietor. Enter your individual name as shown on your income tax return on the "Name" line. You may enter your business, trade, or "doing business as (DBA)" name on the "Business name" line.

Limited liability company (LLC). Check the "Limited liability company" box only and enter the appropriate code for the tax classification ("D" for disregarded entity, "C" for corporation, "P" for partnership) in the space provided.

For a single-member LLC (including a foreign LLC with a domestic owner) that is disregarded as an entity separate from its owner under Regulations section 301.7701-3, enter the owner's name on the "Name" line. Enter the LLC's name on the "Business name" line.

For an LLC classified as a partnership or a corporation, enter the LLC's name on the "Name" line and any business, trade, or DBA name on the "Business name" line.

Other entities. Enter your business name as shown on required federal tax documents on the "Name" line. This name should match the name shown on the charter or other legal document creating the entity. You may enter any business, trade, or DBA name on the "Business name" line.

Note. You are requested to check the appropriate box for your status (individual/sole proprietor, corporation, etc.).

Exempt Payee

If you are exempt from backup withholding, enter your name as described above and check the appropriate box for your status, then check the "Exempt payee" box in the line following the business name, sign and date the form.

Generally, individuals (including sole proprietors) are not exempt from backup withholding. Corporations are exempt from backup withholding for certain payments, such as interest and dividends.

Note. If you are exempt from backup withholding, you should still complete this form to avoid possible erroneous backup withholding.

The following payees are exempt from backup withholding:

1. An organization exempt from tax under section 501(a), any IRA, or a custodial account under section 403(b)(7) if the account satisfies the requirements of section 401(f)(2),
2. The United States or any of its agencies or instrumentalities,
3. A state, the District of Columbia, a possession of the United States, or any of their political subdivisions or instrumentalities,
4. A foreign government or any of its political subdivisions, agencies, or instrumentalities, or
5. An international organization or any of its agencies or instrumentalities.

Other payees that may be exempt from backup withholding include:

6. A corporation,
7. A foreign central bank of issue,
8. A dealer in securities or commodities required to register in the United States, the District of Columbia, or a possession of the United States,
9. A futures commission merchant registered with the Commodity Futures Trading Commission,
10. A real estate investment trust,
11. An entity registered at all times during the tax year under the Investment Company Act of 1940,
12. A common trust fund operated by a bank under section 584(a),
13. A financial institution,
14. A middleman known in the investment community as a nominee or custodian, or
15. A trust exempt from tax under section 664 or described in section 4947.

The chart below shows types of payments that may be exempt from backup withholding. The chart applies to the exempt payees listed above, 1 through 15.

IF the payment is for . . .	THEN the payment is exempt for . . .
Interest and dividend payments	All exempt payees except for 9
Broker transactions	Exempt payees 1 through 13. Also, a person registered under the Investment Advisers Act of 1940 who regularly acts as a broker
Barter exchange transactions and patronage dividends	Exempt payees 1 through 5
Payments over \$600 required to be reported and direct sales over \$5,000 ¹	Generally, exempt payees 1 through 7

¹ See Form 1099-MISC, Miscellaneous Income, and its instructions.

² However, the following payments made to a corporation (including gross proceeds paid to an attorney under section 6045(f), even if the attorney is a corporation) and reportable on Form 1099-MISC are not exempt from backup withholding: medical and health care payments, attorneys' fees, and payments for services paid by a federal executive agency.

Part I. Taxpayer Identification Number (TIN)

Enter your TIN in the appropriate box. If you are a resident alien and you do not have and are not eligible to get an SSN, your TIN is your IRS individual taxpayer identification number (ITIN). Enter it in the social security number box. If you do not have an ITIN, see *How to get a TIN* below.

If you are a sole proprietor and you have an EIN, you may enter either your SSN or EIN. However, the IRS prefers that you use your SSN.

If you are a single-member LLC that is disregarded as an entity separate from its owner (see *Limited liability company (LLC)* on page 2), enter the owner's SSN (or EIN, if the owner has one). Do not enter the disregarded entity's EIN. If the LLC is classified as a corporation or partnership, enter the entity's EIN.

Note. See the chart on page 4 for further clarification of name and TIN combinations.

How to get a TIN. If you do not have a TIN, apply for one immediately. To apply for an SSN, get Form SS-5, Application for a Social Security Card, from your local Social Security Administration office or get this form online at www.ssa.gov. You may also get this form by calling 1-800-772-1213. Use Form W-7, Application for IRS Individual Taxpayer Identification Number, to apply for an ITIN, or Form SS-4, Application for Employer Identification Number, to apply for an EIN. You can apply for an EIN online by accessing the IRS website at www.irs.gov/businesses and clicking on Employer Identification Number (EIN) under Starting a Business. You can get Forms W-7 and SS-4 from the IRS by visiting www.irs.gov or by calling 1-800-TAX-FORM (1-800-829-3676).

If you are asked to complete Form W-9 but do not have a TIN, write "Applied For" in the space for the TIN, sign and date the form, and give it to the requester. For interest and dividend payments, and certain payments made with respect to readily tradable instruments, generally you will have 60 days to get a TIN and give it to the requester before you are subject to backup withholding on payments. The 60-day rule does not apply to other types of payments. You will be subject to backup withholding on all such payments until you provide your TIN to the requester.

Note. Entering "Applied For" means that you have already applied for a TIN or that you intend to apply for one soon.

Caution: A disregarded domestic entity that has a foreign owner must use the appropriate Form W-8.

Part II. Certification

To establish to the withholding agent that you are a U.S. person, or resident alien, sign Form W-9. You may be requested to sign by the withholding agent even if items 1, 4, and 5 below indicate otherwise.

For a joint account, only the person whose TIN is shown in Part I should sign (when required). Exempt payees, see *Exempt Payee* on page 2.

Signature requirements. Complete the certification as indicated in 1 through 5 below.

1. Interest, dividend, and barter exchange accounts opened before 1984 and broker accounts considered active during 1983. You must give your correct TIN, but you do not have to sign the certification.

2. Interest, dividend, broker, and barter exchange accounts opened after 1983 and broker accounts considered inactive during 1983. You must sign the certification or backup withholding will apply. If you are subject to backup withholding and you are merely providing your correct TIN to the requester, you must cross out item 2 in the certification before signing the form.

3. Real estate transactions. You must sign the certification. You may cross out item 2 of the certification.

4. Other payments. You must give your correct TIN, but you do not have to sign the certification unless you have been notified that you have previously given an incorrect TIN. "Other payments" include payments made in the course of the requester's trade or business for rents, royalties, goods (other than bills for merchandise), medical and health care services (including payments to corporations), payments to a nonemployee for services, payments to certain fishing boat crew members and fishermen, and gross proceeds paid to attorneys (including payments to corporations).

5. Mortgage interest paid by you, acquisition or abandonment of secured property, cancellation of debt, qualified tuition program payments (under section 529), IRA, Coverdell ESA, Archer MSA or HSA contributions or distributions, and pension distributions. You must give your correct TIN, but you do not have to sign the certification.

Secure Your Tax Records from Identity Theft

Identity theft occurs when someone uses your personal information such as your name, social security number (SSN), or other identifying information, without your permission, to commit fraud or other crimes. An identity thief may use your SSN to get a job or may file a tax return using your SSN to receive a refund.

To reduce your risk:

- Protect your SSN,
- Ensure your employer is protecting your SSN, and
- Be careful when choosing a tax preparer.

Call the IRS at 1-800-829-1040 if you think your identity has been used inappropriately for tax purposes.

Victims of identity theft who are experiencing economic harm or a system problem, or are seeking help in resolving tax problems that have not been resolved through normal channels, may be eligible for Taxpayer Advocate Service (TAS) assistance. You can reach TAS by calling the TAS toll-free case intake line at 1-877-777-4778 or TTY/TDD 1-800-829-4059.

Protect yourself from suspicious emails or phishing schemes. Phishing is the creation and use of email and websites designed to mimic legitimate business emails and websites. The most common act is sending an email to a user falsely claiming to be an established legitimate enterprise in an attempt to scam the user into surrendering private information that will be used for identity theft.

The IRS does not initiate contacts with taxpayers via emails. Also, the IRS does not request personal detailed information through email or ask taxpayers for the PIN numbers, passwords, or similar secret access information for their credit card, bank, or other financial accounts.

If you receive an unsolicited email claiming to be from the IRS, forward this message to phishing@irs.gov. You may also report misuse of the IRS name, logo, or other IRS personal property to the Treasury Inspector General for Tax Administration at 1-800-366-4484. You can forward suspicious emails to the Federal Trade Commission at: spam@uce.gov or contact them at www.consumer.gov/idtheft or 1-877-IDTHEFT(438-4338).

Visit the IRS website at www.irs.gov to learn more about identity theft and how to reduce your risk.

What Name and Number To Give the Requester

For this type of account:	Give name and SSN of:
1. Individual	The individual
2. Two or more individuals (joint account)	The actual owner of the account or, if combined funds, the first individual on the account ¹
3. Custodian account of a minor (Uniform Gift to Minors Act)	The minor ²
4. a. The usual revocable savings trust (grantor is also trustee)	The grantor-trustee ³
b. So-called trust account that is not a legal or valid trust under state law	The actual owner ³
5. Sole proprietorship or disregarded entity owned by an individual	The owner ³
For this type of account:	Give name and EIN of:
6. Disregarded entity not owned by an individual	The owner
7. A valid trust, estate, or pension trust	Legal entity ⁴
8. Corporate or LLC electing corporate status on Form 8832	The corporation
9. Association, club, religious, charitable, educational, or other tax-exempt organization	The organization
10. Partnership or multi-member LLC	The partnership
11. A broker or registered nominee	The broker or nominee
12. Account with the Department of Agriculture in the name of a public entity (such as a state or local government, school district, or prison) that receives agricultural program payments	The public entity

¹ List first and circle the name of the person whose number you furnish. If only one person on a joint account has an SSN, that person's number must be furnished.

² Circle the minor's name and furnish the minor's SSN.

³ You must show your individual name and you may also enter your business or "DBA" name on the second name line. You may use either your SSN or EIN (if you have one), but the IRS encourages you to use your SSN.

⁴ List first and circle the name of the trust, estate, or pension trust. (Do not furnish the TIN of the personal representative or trustee unless the legal entity itself is not designated in the account title.) Also see *Special rules for partnerships* on page 1.

Note. If no name is circled when more than one name is listed, the number will be considered to be that of the first name listed.

Privacy Act Notice

Section 6109 of the Internal Revenue Code requires you to provide your correct TIN to persons who must file information returns with the IRS to report interest, dividends, and certain other income paid to you, mortgage interest you paid, the acquisition or abandonment of secured property, cancellation of debt, or contributions you made to an IRA, or Archer MSA or HSA. The IRS uses the numbers for identification purposes and to help verify the accuracy of your tax return. The IRS may also provide this information to the Department of Justice for civil and criminal litigation, and to cities, states, the District of Columbia, and U.S. possessions to carry out their tax laws. We may also disclose this information to other countries under a tax treaty, to federal and state agencies to enforce federal nontax criminal laws, or to federal law enforcement and intelligence agencies to combat terrorism.

You must provide your TIN whether or not you are required to file a tax return. Payers must generally withhold 28% of taxable interest, dividend, and certain other payments to a payee who does not give a TIN to a payer. Certain penalties may also apply.

**WORKER'S COMPENSATION CERTIFICATION
2011 SPEED HUMPS PROJECT**

In accordance with Article 5 (commencing at Section 1860), Chapter 1, Part 7, Division 2 of the Labor Code, the below certificate must be signed and filed with the awarding body prior to performing any work under this contract. Labor Code Section 3700, inter alia, states the following:

"Every employer shall secure the payment of compensation in one or more of the following ways:

- "(a) By being insured against liability to pay compensation in one or more insurers duly authorized to write compensation insurance in this State.
- "(b) By securing from the Director of Industrial Relations a certificate of consent to self-insure, which may be given upon furnishing proof satisfactory to the Director of Industrial Relations of ability to self-insure and to pay any compensation that may become due to his employees.

To be signed by authorized corporate officer or partner or individual submitting the Proposal. If Bidder is: (example)

1. An individual using a firm name, sign: "John Doe, an individual doing business as Blank Company."
2. An individual doing business under his own name, Sign: your name only.
3. A co-partnership, sign: "John Doe and Richard Doe, co-partners doing business as Blank Company, by, John Doe, co-partner.
4. A corporation, sign: "Blank Company, by John Doe, Secretary." (or other title)

I am aware of the provisions of Section 3700 of the Labor Code which require every employer to be insured against liability for worker's compensation or to undertake self-insurance in accordance with the provisions of that code, and I will comply with such provisions before commencing the performance of the work of this contract.

DATE: 09/20/2011

Contractor RML Paving

By  _____
Signature

GUARANTEE

We hereby guarantee the 2011 SEAL COAT PROJECT (PN: R15112020) to the City of Sacramento for one (1) year in accordance with the guarantee required in the specifications. We agree to repair or replace any or all such work, together with all or any other work which may be displaced in so doing, that may be proven defective in workmanship or material within the one-year period from the date of acceptance without any expense whatsoever to the City, ordinary wear and tear and unusual abuse or neglect excepted.

In the event of our failure to comply with the above-mentioned conditions within five (5) days time after being notified in writing, we collectively or separately, do hereby authorize the City to proceed to have the defects repaired and made good at our expense and will pay the costs and damages, including but not limited to any related attorney fees and City staff and administrative expenses, therefor immediately upon demand.

Dated: 9/20/2011

Signed:



Rodolfo Martinez Luna
Printed Name

RML Paving
Company

7431 Peacock way
Address

Sacramento CA 95820

SPECIAL PROVISIONS

TABLE OF CONTENTS

**SPECIAL PROVISIONS FOR
2011 SPEED HUMPS PROJECT
(PN: S15101200)**

01. GENERAL REQUIREMENTS1

1.1 SCOPE OF WORK..... 1

1.2 COMPLETION TIME..... 1

1.3 SPECIFICATIONS..... 1

1.4 TIME OF AWARD..... 1

1.5 SIGNING OF AGREEMENT AND BONDS..... 2

1.6 PRE-BID INTERPRETATION OF CONTRACT DOCUMENTS 2

1.7 REVIEW OF CONTRACTOR'S INFORMATION 2

1.8 PROJECT SCHEDULE..... 3

1.9 WATER QUALITY CONTROL..... 3

1.10 STORAGE OF MATERIALS AND EQUIPMENT 6

1.11 CLEANING UP..... 6

1.12 PROTECTION OF TREES..... 6

1.13 PROTECTION OF EXISTING IMPROVEMENTS 7

1.14 TRAFFIC CONTROL PLAN, PUBLIC SAFETY AND CONVENIENCE..... 7

1.15 PUBLIC NOTIFICATION 8

1.16 REMOVAL OF ON-STREET PARKING..... 8

1.17 COORDINATION WITH TRAFFIC ENGINEERING AND SIGNS & MARKINGS DIVISIONS AND
COUNTY OF SACRAMENTO 9

1.18 COOPERATION 10

1.19 PROTECTION OF SURVEY MONUMENTS 10

1.20 WORK AFFECTING THE PUBLIC RIGHTS OF WAY 10

1.21 NO TRUCK HAUL ROUTE ON 28TH STREET SOUTH OF E STREET 11

02. ITEMS OF THE PROPOSAL.....12

ITEM NO. 1 - ASPHALTIC CONCRETE SPEED LUMP TO CONSTRUCT 12

ITEM NO. 2 - ASPHALTIC CONCRETE TABLE TO CONSTRUCT 13

03. APPENDIX.....14

**SPECIAL PROVISIONS
FOR
2011 SPEED HUMPS PROJECT
(PN: S15101200)**

1. GENERAL REQUIREMENTS

1.1 SCOPE OF WORK

The work to be done consists, in general, of constructing asphaltic concrete speed lumps or speed tables over existing pavement. New signs, sign posts, bollards and striping shall be furnished and installed by the City.

There shall be one (1) speed lump per location. The location of speed lumps are listed and indicated on maps in Exhibit B of the Appendix of these Special Provisions.

There shall be one (1) speed table per location. The location of speed tables are listed and indicated on maps in Exhibit C of the Appendix of these Special Provisions.

1.2 COMPLETION TIME

The time limit for the completion of all work is **SIXTY (60)** working days from the date on the Notice to Proceed. Should said work not be completed to the satisfaction of the City within said time, the contractor shall pay the City of Sacramento a sum of **NINE HUNDRED DOLLARS (\$900)** as liquidated damages and not as a penalty, for each calendar day delay after the expiration of such period until the final acceptance of the work by the city and its delivery to the City.

1.3 SPECIFICATIONS

The work to be performed under this contract shall be done in accordance with the Special Provisions contained herein. In these Special Provisions, reference is made to the Standard Specifications of the City of Sacramento, adopted June 2007 and all updates to them, which shall apply to the work. The general requirements of this contract shall be governed by Sections 1 through 8 of the Standard Specifications. The Special Provisions shall govern first, followed by the Standard Specifications. Other Standards specified in these Special Provisions govern only the applicable technical Specifications.

Wherever reference is made to City Manager, Director of Public Works, Engineer, Finance Director, Inspector, Landscape Architect, or other specifically identified individuals, it shall include their designated representative.

1.4 TIME OF AWARD

Section 3-2, "Time of Award," of the Standard Specifications is hereby amended for this project. Time of Award for this contract shall be made within forty-five (45) calendar days after opening of the proposals to the lowest responsible bidder, unless otherwise stated in the contract agreement.

1.8 PROJECT SCHEDULE

The Contractor shall submit to the Engineer a practicable progress schedule at the pre-construction meeting, and within 3 working days of the Engineer's written request at any other time. The Contractor shall furnish the schedule on a form of his choice. The schedule shall show the order in which the Contractor proposes to carry out the work, the dates on which he will start the features of the work, and the contemplated dates for completion of the work.

The progress schedules submitted shall be consistent in all respects with the time and order of work requirements of the contract.

Subsequent to the time that submittal of a progress schedule is required in accordance with these specifications, no progress payments will be made for any work until a satisfactory schedule has been submitted to and approved by the Engineer.

1.9 WATER QUALITY CONTROL

These requirements consist of regulations contained in the National Pollution Discharge Elimination System (NPDES) Stormwater Permit issued to the City.

1. Dust Control

The Contractor shall be responsible for the control of dust within the limits of the project at all times including weekends and holidays in addition to normal working days. The Contractor shall take whatever steps are necessary or required by the Engineer to eliminate the nuisance of blowing dust **without causing sediment, debris or litter to enter the City storm drain system.**

2. Erosion, Sediment, and Pollution Control

The Contractor shall be responsible for controlling erosion and sedimentation within the limits of the project at all times during the course of construction including evenings, weekends and holidays in addition to normal working days. The Contractor shall prevent sediment and construction debris from entering the City storm drain system.

The Contractor shall provide the following erosion, sediment, and pollution control Best Management Practices (BMPs) when and where applicable (also see attached details):

- Filter Bags in and Gravel bags around any storm drain inlets which receive runoff from the limits of the construction zone, including storage and staging areas. Alternative storm drain inlet protection BMPs can be used with approval of the Engineer.
- Covering of material piles and/or gravel berms (or approved equal) around material piles as required to prevent migration of material to gutters or storm drains.
- Gutter flowlines are to be kept unimpeded and free of soil, debris and construction materials at all times.
- Stabilized construction entrance at any soil to concrete/asphalt interface used by Contractor vehicles and equipment.
- Silt fences, fiber rolls or approved equal at any soil to concrete/asphalt interface at which soil may be washed onto the concrete/asphalt.

and sub-contractors about preventing spills of hazardous materials, including equipment fuel, and controlling spills if they occur. Proper spill control and cleanup materials and procedures shall be kept on site near the storage and equipment fueling areas and updated as materials change on site. Contractor will be held strictly responsible for the prevention, clean-up and consequences of any hazardous materials spills.

Throughout the duration of the project the Contractor will be required to inspect and maintain, in effective condition, all erosion, sediment, and pollution control BMPs before and after each storm event and as needed. The contractor shall immediately correct or replace any ineffective BMPs.

More information about control measures and housekeeping practices can be obtained by referring to the City of Sacramento's Administrative and Technical Procedures Manual for Grading, Erosion, and Sediment Control available at 1395 35th Avenue, Sacramento, CA 95822.

The Contractor shall prepare and submit an erosion, sediment and pollution control plan (ESC Plan) to the Engineer for review, per Section 1.6, Review of Contractor's Information, of these Special Provisions. The submittal shall include a description of all erosion, sediment and pollution control BMPs proposed to be used to prevent sediment and other sources of pollution from entering the City storm drain system as well as a site plan showing their placement. The ESC Plan shall be submitted a minimum of 48 hours prior to start of the work. **The Contractor will not be allowed to begin work until an accepted ESC Plan is on file with the Engineer.** The erosion, sediment and pollution control plan shall be updated as necessary and re-submitted to the Engineer.

3. Enforcement

Per City Code Sections 15.88, 13.16 and 1.28, the Contractor shall be subject to Notices of Violation (NOVs) resulting in possible Stop Work Orders and Administrative Penalties of up to \$4,999 per day for non-compliance of this section of the Special Provisions.

Per the State's Porter Cologne Water Quality Act, the Contractor shall also be subject to inspection by Staff from the Central Valley Regional Water Quality Control Board who have the authority to issue Notices of Violation (NOVs) and Penalties of up to \$10,000 per day for non-compliance. The Contractor shall be liable for any fines issued to the project by the State or Federal Government for NPDES non-compliance due to Contractor negligence.

The City reserves the right to take corrective action and withhold the City's costs for corrective action from progress payments or final payment in accordance with Section 7, Retention of Sums Charged against the Contractor, of the Agreement.

Any fines, including third-party claims, levied against the Agency as a result of Contractor's non-compliance are the Contractor's sole responsibility and will be withheld from progress payments or final payment in accordance with Section 7, Retention of Sums Charged against the Contractor, of the Agreement.

- If, during construction grading, tree roots two inches (2") in diameter or greater are encountered, work shall stop immediately and the City Arborist shall be contacted for a root inspection, and the root shall not be cut unless the Arborist approves. Roots approved by the Arborist to be severed during the course of project construction shall be neatly trimmed. If a large number of roots require cutting, the tree will then have to be evaluated by the certified arborist for possible removal.
 - If construction activities will affect any of the limbs of the trees, a certified arborist (certified by International Society of Arborists, Western Chapter) shall be consulted prior to the cutting or removal of any limb. Limbs approved by the arborist to be severed during the course of project construction shall be neatly trimmed.
 - The Contractor shall be responsible for damages to trees. Trees damaged by the Contractor during construction activities shall be assessed by the City Arborist using the International Society of Arborists (ISA) appraisal guide. The Contractor's responsibility for damaged trees will be determined by the Arborist.
-
- No roots shall be cut for the reconstruction of the existing driveway approaches without the approval of the City Arborist.
 - Supplemental irrigation will be required for trees on and adjacent to the project site where the irrigation has been turned off or modified because of construction activities.

Full compensation for furnishing all labor, materials, tools, equipment and incidentals and for doing all work involved in this section shall be considered as included in the prices paid for various contract items of work and no additional compensation will be allowed therefor.

1.13 PROTECTION OF EXISTING IMPROVEMENTS

Existing improvements and adjacent property shall be protected from damage resulting from the Contractor's operations. All trees, shrubbery, fences, walls and other improvements including existing pavements, sidewalks, street improvements and underground utilities and other improvements not to be removed under this contract shall be protected from damage by the Contractor throughout the construction period.

All painted or other disfiguring markings on the pavement, sidewalk or gutters shall be removed by the Contractor before acceptance of the work.

The Contractor shall be liable for costs of repairing damage to existing improvements.

The cost for protection of existing improvements shall be included with those bid items the bidder deems appropriate.

1.14 TRAFFIC CONTROL PLAN, PUBLIC SAFETY AND CONVENIENCE

The Contractor's attention is directed to Sections 6-6, 6-8, and 6-9 of the Standard Specifications.

1. In Metered Parking Areas:

Forty-eight (48) hours prior to construction, the Contractor shall place signs adjacent to every fourth parking stall stating "NO PARKING - (specific times and dates) - Tow Away" or "NO PARKING - (specific times and dates) - This Block."

Three (3) hours prior to construction, the Contractor shall cover each parking meter with a "NO PARKING" sign, and the signs previously placed adjacent to every fourth stall shall be mounted on a barricade and moved into the stall.

If the Contractor needs less than the entire block, then every stall removed shall be barricaded in conjunction with the covering of the parking meters.

The Contractor shall coordinate parking removal with the City Parking Division (808-2690). There is no charge for removal of metered parking spaces used during construction activities. However, metered parking spaces removed and not used during the day's construction will be charged to the Contractor. The Parking Division shall determine which meters were removed and not used on a given day and make said charges.

2. In Non-Metered Parking Areas:

Forty-eight (48) hours prior to construction, the Contractor shall place signed barricades stating "NO PARKING - (specific times and dates) - Tow Away" or "NO PARKING - (specific times and dates) - This Block," at 50 to 60 foot intervals in the work area.

"NO PARKING" signs and mounting barricade shall be approved by the Parking Division prior to their use.

The Contractor shall notify the Parking Division immediately after the "NO PARKING" signs are in place. "NO PARKING" signs, hoods and barricades shall be supplied by the Contractor.

Failure to comply with this section will prevent the City from towing vehicles parked in the proposed work area.

Full compensation for furnishing all labor, materials, tools, equipment and incidentals, and for payment of all fees and for doing all work involved in removal of on-street parking shall be considered as included in the prices paid for various contract items of work and no additional compensation will be allowed therefore.

**1.17 COORDINATION WITH TRAFFIC ENGINEERING AND SIGNS & MARKINGS
DIVISIONS AND COUNTY OF SACRAMENTO**

The Contractor shall notify the Engineer (for coordination with the Traffic Engineer) a minimum of three (3) working days prior to the construction of the speed lumps, speed tables and speed lump conversions. It is the responsibility of the contractor to notify the Engineer adequate time in advance to mark the location of each speed lump, speed table and speed lump conversion on the pavement for the

1.21 NO TRUCK HAUL ROUTE ON 28TH STREET SOUTH OF E STREET

The Contractor and its subcontractors must not use 28th Street south of E Street as part of any haul route to and from the Bell Marine Co., Inc./Harbor Sand and Gravel located at 200 28th Street. Acceptable routes to and from the facility are as follows:

To enter facility:

- North on 30th Street
- West on E Street
- North on 28th Street

To exit facility:

- South on 28th Street
- East on C Street
- South on 29th Street

The Contractor shall be assessed an administrative penalty of \$1000 for each Contractor or subcontractor dump truck that uses 28th Street South of E Street to enter or exit the Bell Marine Co., Inc./Harbor Sand and Gravel.

ITEM NO. 2 - ASPHALTIC CONCRETE TABLE TO CONSTRUCT

This item shall consist of placing asphaltic concrete speed tables at such places as designated herein, or by the Engineer, in accordance with these Special Provisions and in conformity to Exhibit C of the Appendix.

Construction of asphaltic concrete speed tables shall be Type A, ½" fine conforming to Section 22 of the Standard Specifications except that asphaltic concrete shall be placed only when the ambient air temperature is 60° F and rising. The tack coat shall be applied at the rate of 0.05 to 0.15 gallons per square yard prior to paving operations.

As directed by the Engineer, suitable feathered connections to existing pavement shall be made. The Engineer will not accept any speed table that is less than three and one quarter inches (3 ¼") in height or exceeds a maximum three and three quarter inches (3 ¾") in height or that is not of the shape shown on the drawing in Exhibit C of the Appendix.

The Contractor shall construct speed tables at the general location indicated on the map in Exhibit C of the Appendix of these Special Provisions. The exact location of each speed table indicated on the map will be marked on the pavement by the Traffic Engineering staff. **Please see Exhibit A of the Appendix for design details.**

The Contractor shall contact the Engineer for coordination a minimum of three (3) working days prior to the construction of the speed tables.

Speed tables shall be measured by the lineal foot of street width shown in Exhibit C. This is a final pay item, and no additional compensation will be provided for street widths that vary slightly from Exhibit C.

Payment shall be at the unit price bid per lineal foot of street width and shall include full compensation for furnishing all labor, materials, tools, equipment and incidentals and for doing all work and surface preparation involved in constructing asphaltic concrete speed tables as specified in these Special Provisions and as directed by the Engineer. Payment shall also include the placement and maintenance of temporary reflective "floppy" pavement markers placed on the speed hump in a pattern similar to the permanent striping.

APPENDIX

EXHIBIT A Speed Lump Details A, B, C, & D & Speed Table Detail

EXHIBIT B Speed Lump Street List & Location Maps

EXHIBIT C Speed table list street list and location maps

EXHIBIT A

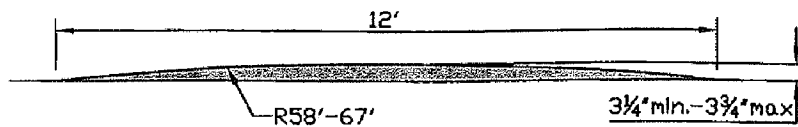

SPEED LUMP CROSS SECTION A-A

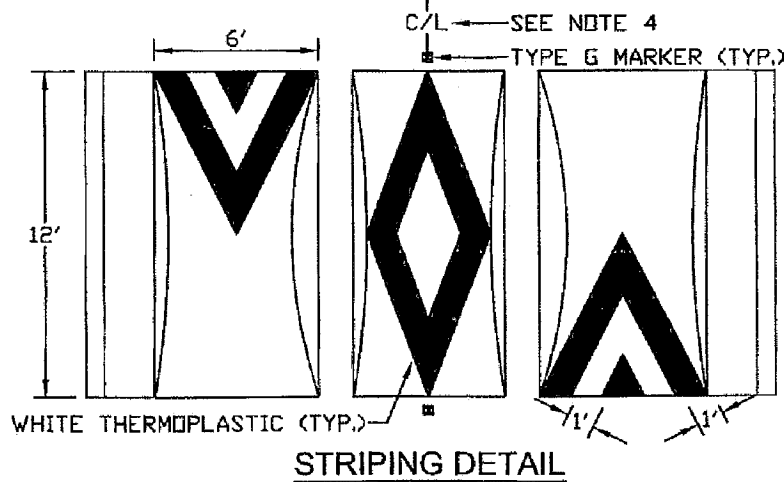
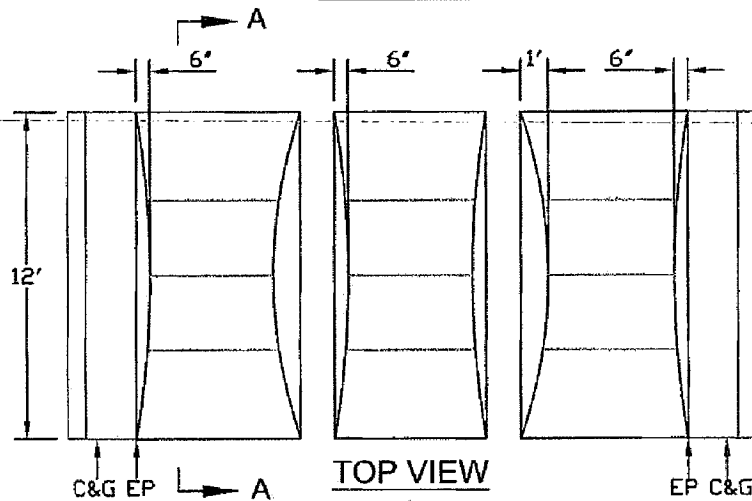
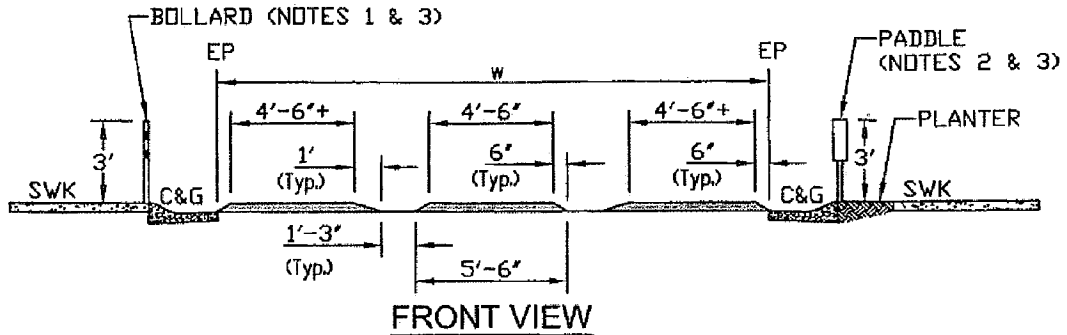

R:\Utilities\Transportation\StdDwg\T-222.dwg

LEGEND:

C&G - CURB AND GUTTER
 EP - EDGE OF PAVEMENT
 SWK - SIDEWALK

NOTES:

1. BOLLARD TO BE INSTALLED ON SIDEWALKS WITH ROLLED CURBS. SEE CITY STANDARD DWG. NO. T-230.
2. PADDLES TO BE INSTALLED ON PLANTER/DIRT WITH ROLLED CURBS OR UNIMPROVED STREETS. SEE CITY STANDARD DWG. NO. T-210.
3. NO BOLLARD OR PADDLE IS NEEDED WHERE TYPE 2 CURB & GUTTER IS PRESENT.
4. CENTER LUMP ON ROADWAY UNLESS OTHERWISE NOTED BY THE ENGINEER.

REV.	DATE	DESCRIPTION
△		
△		
△		

CITY OF SACRAMENTO
 DEPARTMENT OF TRANSPORTATION

SPEED LUMP DETAIL (A)
 (w) < 24'

APPROVED BY: *Jason Pappas* SCALE: None
 DATE: 08/31/09 DWG. NO. T-222

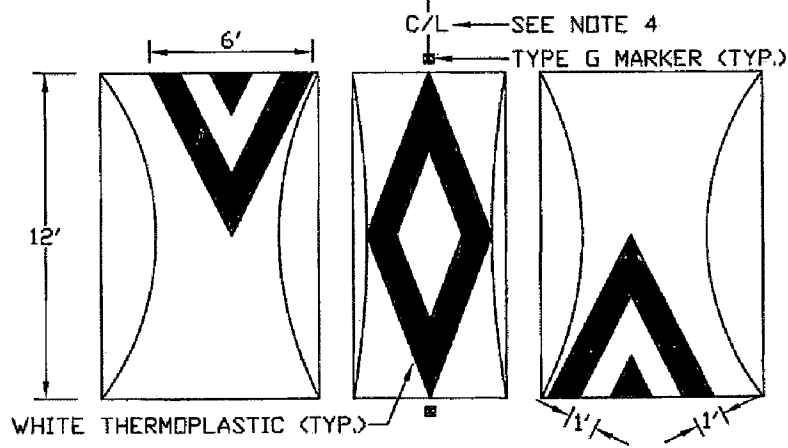
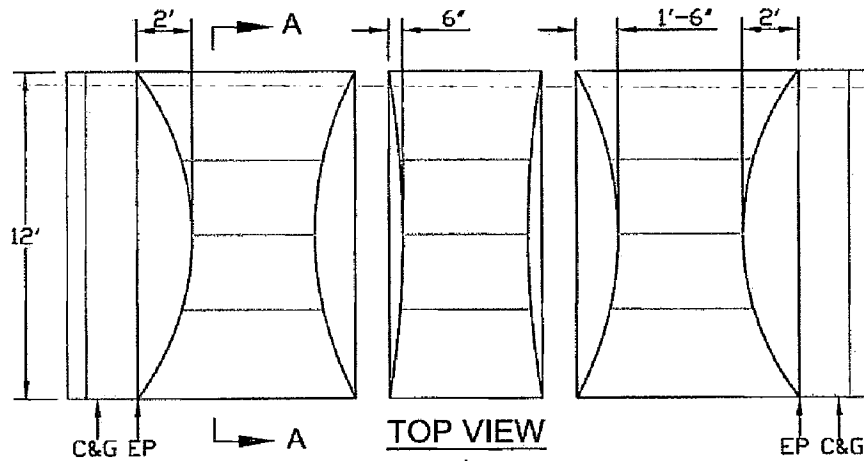
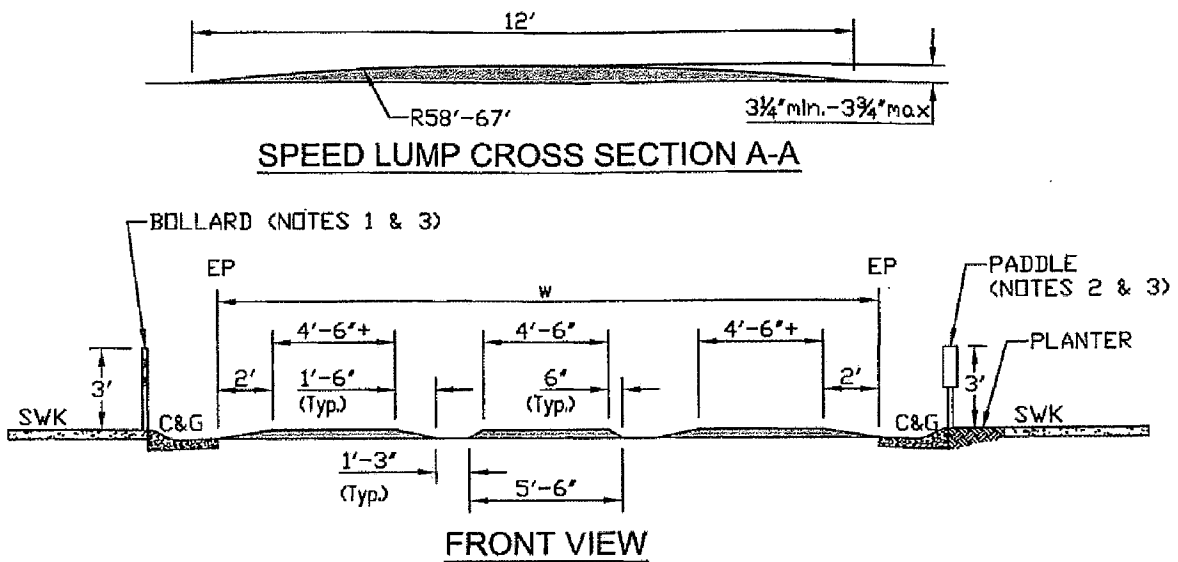

LEGEND:

C&G - CURB AND GUTTER
 EP - EDGE OF PAVEMENT
 SWK - SIDEWALK

NOTES:

1. BOLLARD TO BE INSTALLED ON SIDEWALKS WITH ROLLED CURBS. SEE CITY STANDARD DWG. NO. T-230.
2. PADDLES TO BE INSTALLED ON PLANTER/DIRT WITH ROLLED CURBS OR UNIMPROVED STREETS. SEE CITY STANDARD DWG. NO. T-210.
3. NO BOLLARD OR PADDLE IS NEEDED WHERE TYPE 2 CURB & GUTTER IS PRESENT.
4. CENTER LUMP ON ROADWAY UNLESS OTHERWISE NOTED BY THE ENGINEER.

REV.	DATE	DESCRIPTION
△		
△		
△		

CITY OF SACRAMENTO
 DEPARTMENT OF TRANSPORTATION

SPEED LUMP DETAIL (B)
 (w) ≥24' & <34'

APPROVED BY: *Hector Rios* SCALE: None
 DATE: 08/31/09 DWG. NO. T-223

R:\Util\stds\Transportation\StdDwgs\T-223.dwg

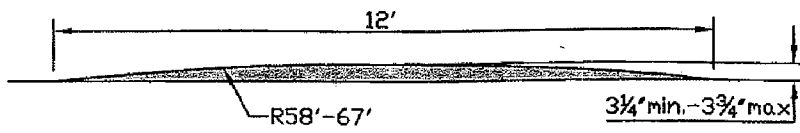

SPEED LUMP CROSS SECTION A-A

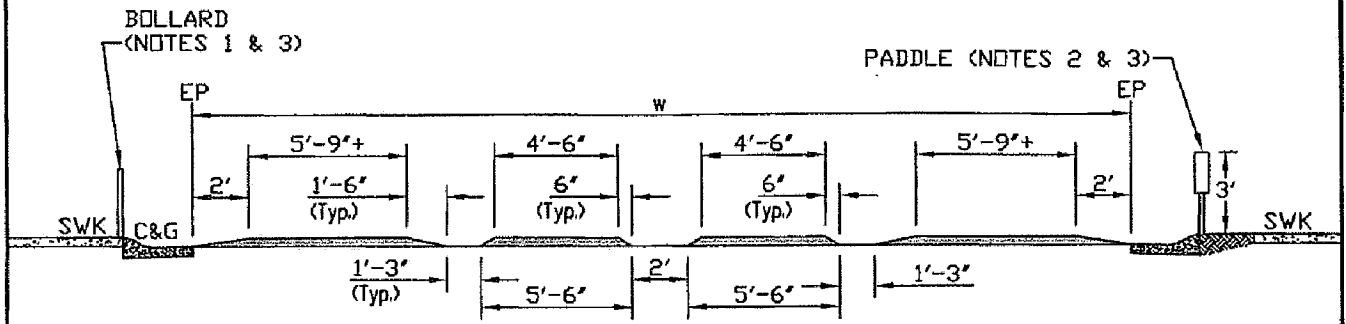

FRONT VIEW

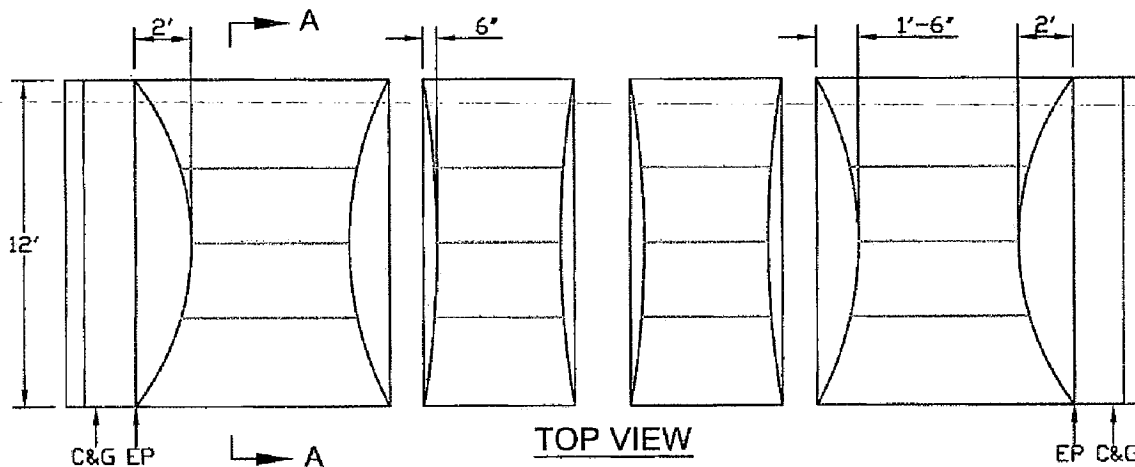

TOP VIEW

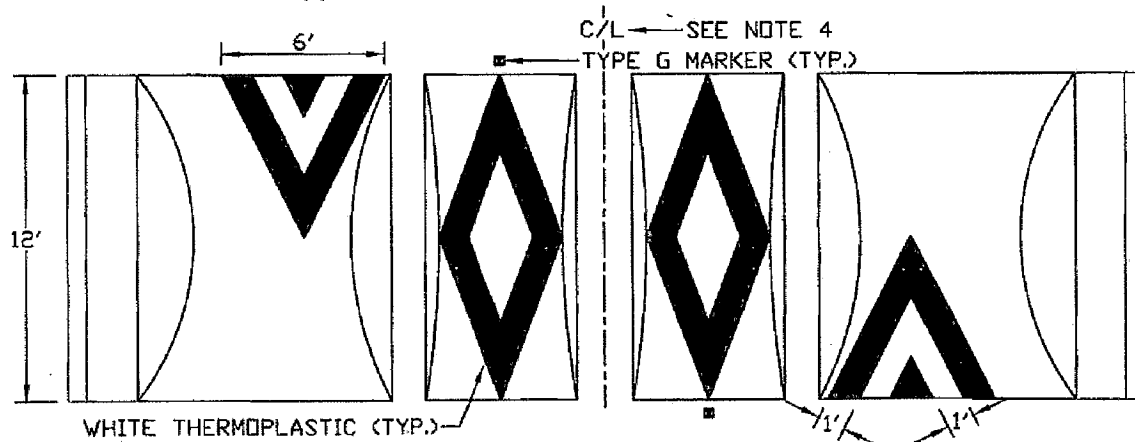

STRIPING DETAIL

LEGEND:

C&G - CURB AND GUTTER
 EP - EDGE OF PAVEMENT
 SWK - SIDEWALK

NOTES:

1. BOLLARD TO BE INSTALLED ON SIDEWALKS WITH ROLLED CURBS. SEE CITY STANDARD DWG. NO. T-230.
2. PADDLES TO BE INSTALLED ON PLANTER/DIRT WITH ROLLED CURBS OR UNIMPROVED STREETS. SEE CITY STANDARD DWG. NO. T-210.
3. NO BOLLARD OR PADDLE IS NEEDED WHERE TYPE 2 CURB & GUTTER IS PRESENT.
4. CENTER LUMP ON ROADWAY UNLESS OTHERWISE NOTED BY THE ENGINEER.

REV.	DATE	DESCRIPTION
△		
△		
△		

R:\Utilities\Transportation\StdDwgs\T-224.dwg

CITY OF SACRAMENTO
 DEPARTMENT OF TRANSPORTATION

SPEED LUMP DETAIL (C)
 (w) ≥ 34' & < 40'

APPROVED BY: *Intechn* *Pa...* SCALE: None
 DATE: 08/31/09 DWG. NO. T-224

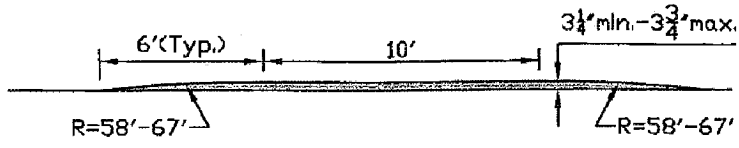

SPEED TABLE CROSS SECTION A-A

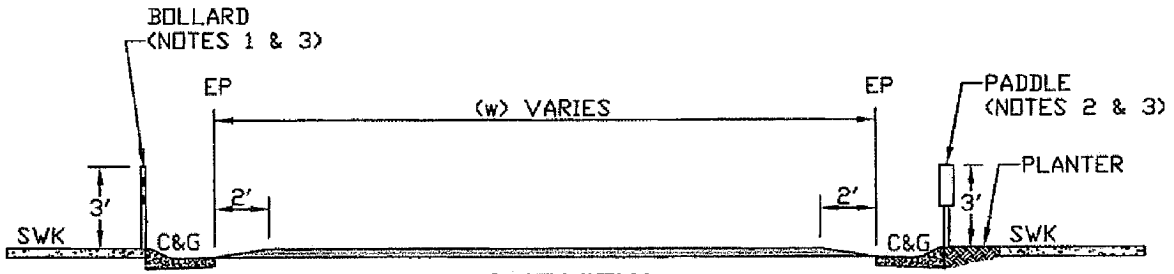

FRONT VIEW

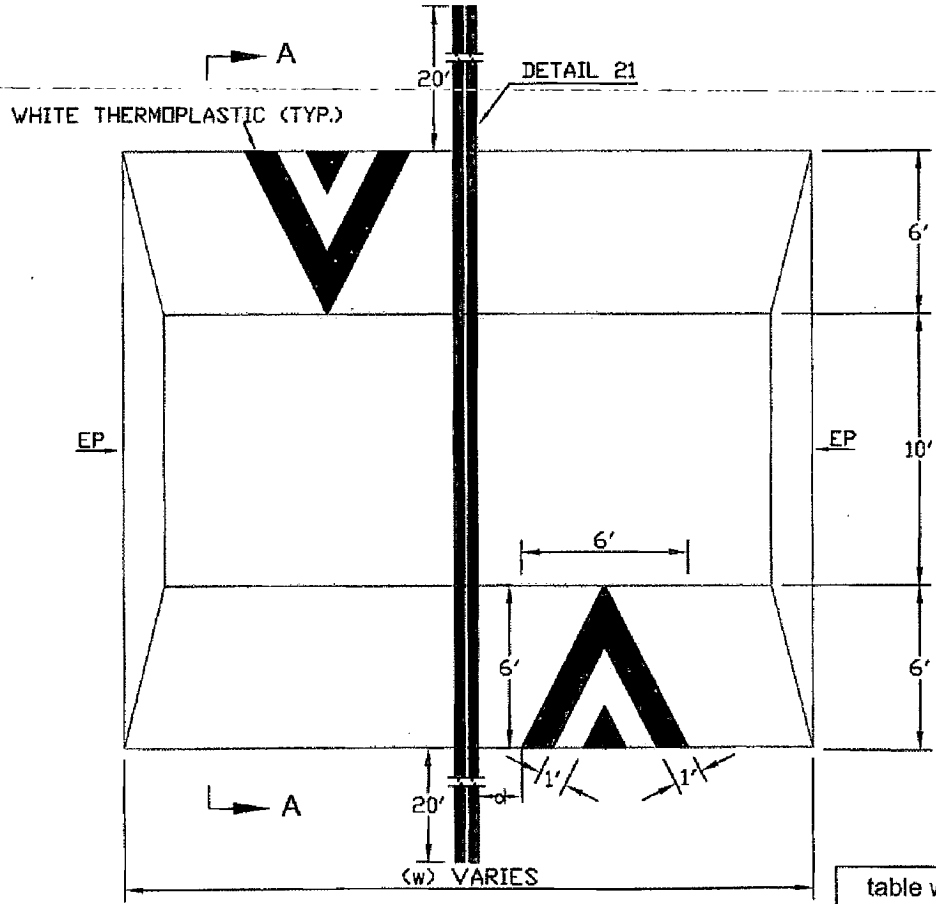

PLAN VIEW & STRIPING PLAN

table width (w)	(d)
20' - 32'	2'-0"
32' +	3'-0"

LEGEND:

C&G - CURB AND GUTTER
 EP - EDGE OF PAVEMENT
 SWK - SIDEWALK

NOTES:

- BOLLARD TO BE INSTALLED ON SIDEWALKS WITH ROLLED CURBS. SEE CITY STANDARD DWG. NO. T-230.
- PADDLES TO BE INSTALLED ON PLANTER/DIRT WITH ROLLED CURBS OR UNIMPROVED STREETS. SEE CITY STANDARD DWG. NO. T-210.
- NO BOLLARD OR PADDLE IS NEEDED WHERE TYPE 2 CURB & GUTTER IS PRESENT.

REV.	DATE	DESCRIPTION
△		
△		
△		

R:\Utilities\Transportation\StdDwgs\T-226.dwg

CITY OF SACRAMENTO
 DEPARTMENT OF TRANSPORTATION

SPEED TABLE DETAIL

APPROVED BY: *[Signature]* SCALE: None
 DATE: 08/31/09 DWG. NO. T-226

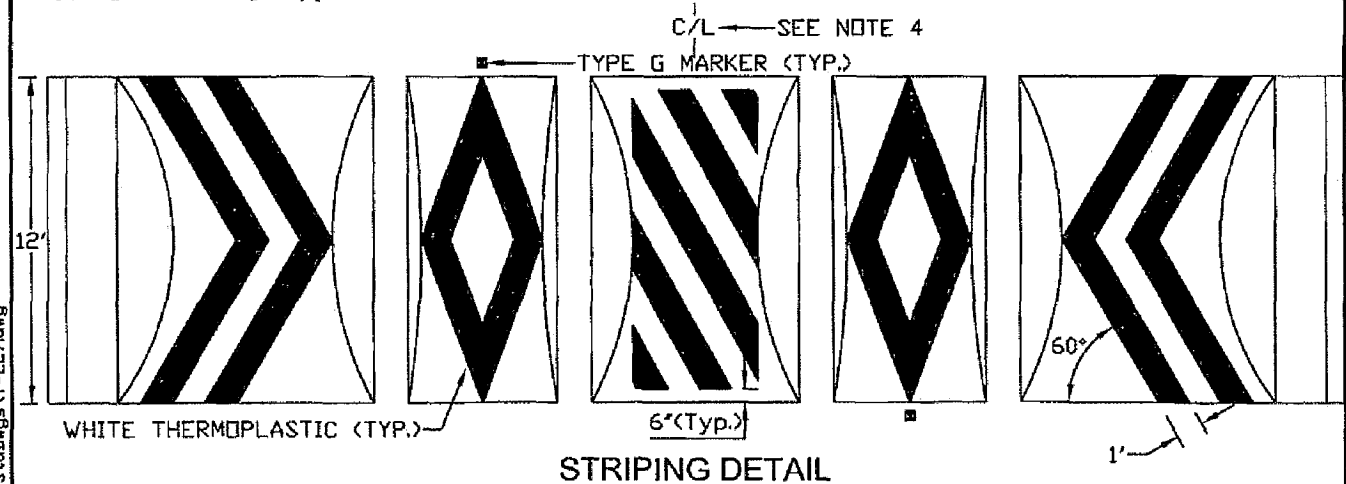
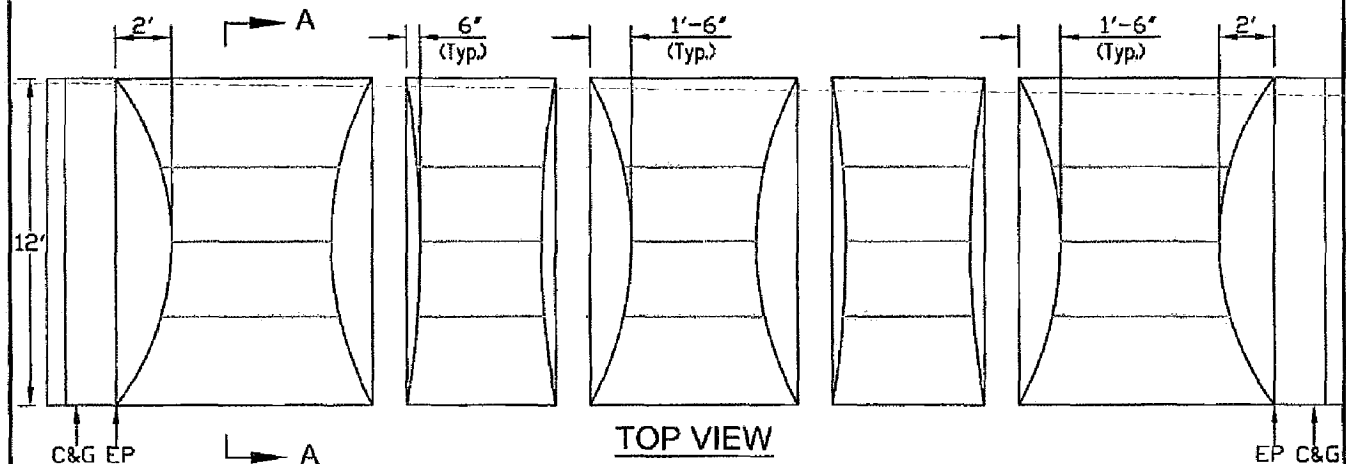
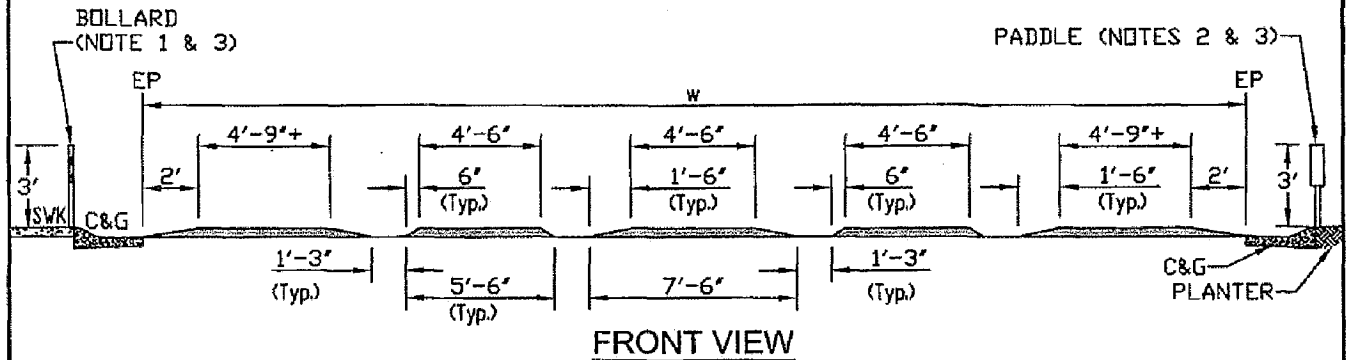
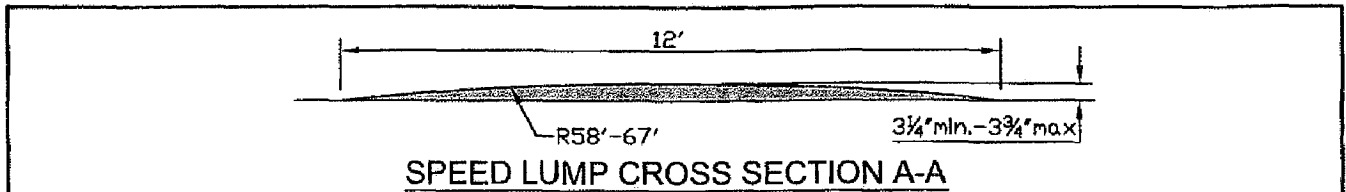

LEGEND:

C&G - CURB AND GUTTER
 EP - EDGE OF PAVEMENT
 SWK - SIDEWALK

NOTES:

1. BOLLARD TO BE INSTALLED ON SIDEWALKS WITH ROLLED CURBS. SEE CITY STANDARD DWG. NO. T-230.
2. PADDLES TO BE INSTALLED ON PLANTER/DIRT WITH ROLLED CURBS OR UNIMPROVED STREETS. SEE CITY STANDARD DWG. NO. T-210.
3. NO BOLLARD OR PADDLE IS NEEDED WHERE TYPE 2 CURB & GUTTER IS PRESENT.
4. CENTER LUMP ON ROADWAY UNLESS OTHERWISE NOTED BY THE ENGINEER.

REV.	DATE	DESCRIPTION
△		
△		
△		

R:\Utilities\Transportation\StdDwgs\T-227.dwg

EXHIBIT B

Location	Between These Streets	Lumps	Width	TB Guide
17th Street	Wakefield Wy/65th Av	2	35	337-C1
19th Street	Matson Dr/Kirk Wy	2	25	337-C3
21st Street	Matson Dr/Meadowview Rd	3	35	337-C3
36th Street	Y St/2nd Av	2	39	297-F7
53rd Avenue	City-County Line/Briggs Dr	2	42	318-B7
53rd Avenue	City-County Line/Briggs Dr	1	34	318-B7
Addison Way	Casa Linda Dr/Meadowview Rd	2	26	337-D3
Airport Road	Tanzanite Av/San Juan Rd	2	22	277-A3
Albatross Way	Marconi Cir/Iris Av	2	21	278-5B
Albatross Way	Iris Av/Helena Av	1	19	278-5B
Arcade Boulevard	Fairfield St/Altos Av	2	26	277-H5
Banfield Drive	Burberry Wy/Club Center Dr	2	35	257-B5
Burberry Way	Mabry Dr/Birk Wy	2	25	257-A4
Burberry Way	Dunlay Dr/Banfield Dr	2	25	257-A4
Casa Linda Drive	Addison Wy/24th St	1	33	337-D3
Collingwood Street	Matson Dr/Meadowview Rd	3	36	337-D3
Cromwell Way	Wakefield Wy/West elbow	1	25	337-C1
Crosby Way	Helena Av/Glenrose Av	1	21	278-6B
Crosby Way	Glenrose Av/Frienza Av	1	20	278-6B
Dunlay Drive	Northborough Dr/Mabry Dr	3	25	257-A4
Dunlay Drive	Mabry Dr/Burberry Wy	2	25	257-B4
Dunlay Drive	Burberry Wy/Club Center Dr	2	25	257-B5
Florin Frontage Road	Amherst St/17th St	2	18	337-C1
Florin Frontage Road	17th St/Cromwell Wy	2	18	337-C1
Florin Frontage Road	Cromwell Wy/21 St	2	18	337-C1
Flowerwood Way	N. Elbow/Windbridge Dr	3	25	336-H2
Frienza Avenue	Van Ness St/Princeton St	1	26	278-6B
Glenrose Avenue	Auburn Bl/Crosby Wy	2	21	278-6B
Glenrose Avenue	Crosby Wy/Plover St	1	21	278-6B
Greg Thatch Circle	Papusas Wy/Tres Peizas Dr	2	35	256-H4
Helena Avenue	Auburn Bl/Plover St	1	21	278-6B
Helena Avenue	Auburn Bl/Plover St	1	32	278-6B
Helena Avenue	Plover St/Albatross Wy	1	21	278-6B
Iris Avenue	Plover St/Albatross Wy	1	25	278-5B
Juliesse Avenue	Albatross Wy/Connie Dr	1	19	278-5B
Kenmar Road	Barros Dr/Sotnip Rd	5	21	257-E7
Kirk Way	21st St/Collingwood Wy	2	25	337-D3
Kirk Way	Collingwood Wy/Tamoshanter Wy	2	25	337-D3
Lejano Way	Osuna Wy/Azevedo Dr	2	25	277-A4
Mabry Drive	Northborough Dr/Dunlay Dr	2	41	257-B4
Mabry Drive	Dunlay Dr/Natomas Bl	3	41	157-B5

**2011
SPEED LUMP
MAPS**

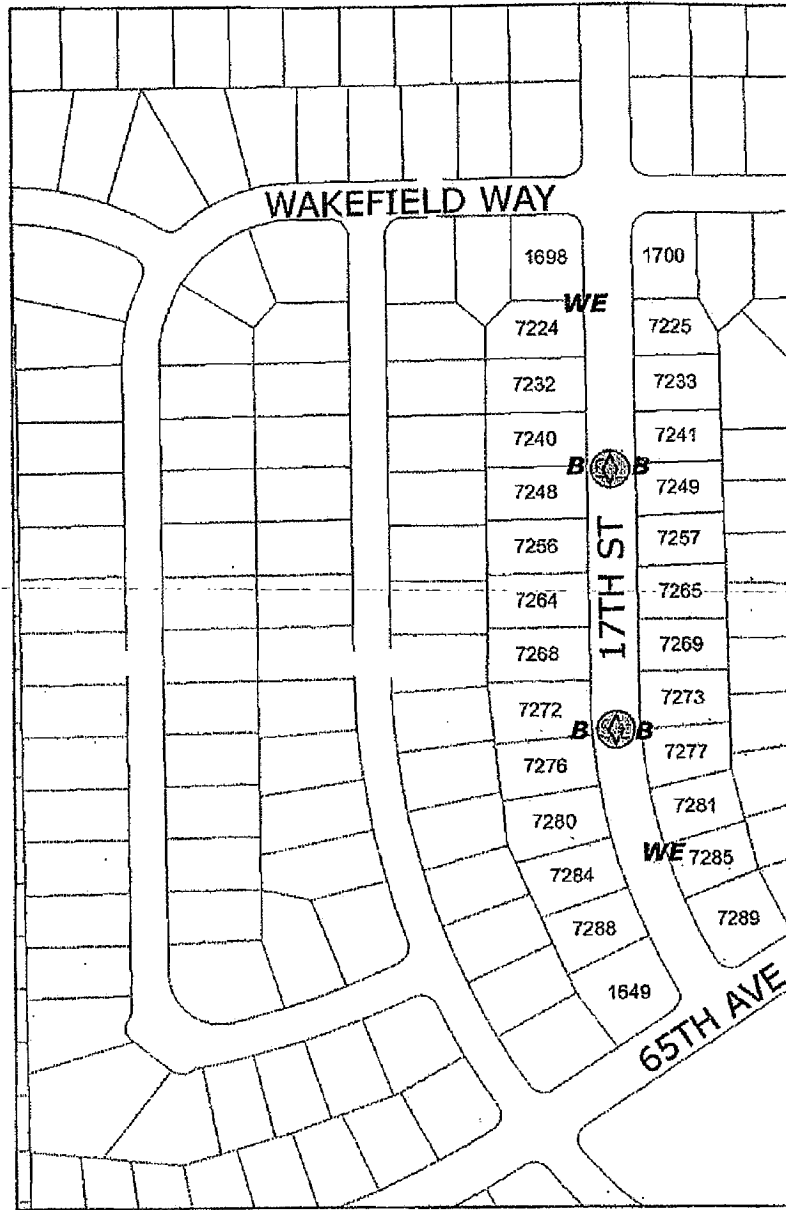

ON: 17TH STREET			
BETWEEN WAKEFIELD WAY			
AND: 65TH AVE			
DEVICE SPEED LUMP			
QTY.	WIDTH (ft)	BOLLARD	4
2	35	PADDLE:	
		WARNING SIGN:	2
		2" PIPE:	
		EXTENSION:	
		ON ELECTROLIER:	2
PN: S15071146		NTMP: WILLOW RANCHO	DISTRICT: 8

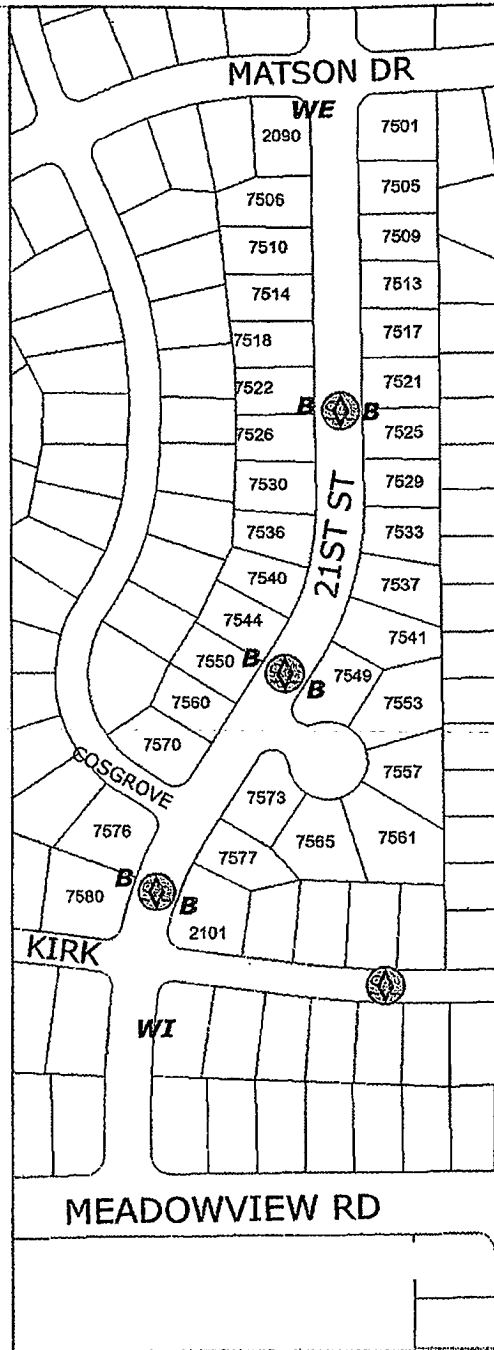

ON: 21ST STREET		BOLLARD: 6	
BETWEEN MATSON DR		PADDLE:	
AND: MEADOWVIEW RD		WARNING SIGN: 2	
DEVICE SPEED LUMP		2" PIPE: 1	
QTY.	WIDTH (ft)	EXTENSION:	
3	35	ON ELECTROLIER: 1	
PN: S15071147		NTMP: VISTA	
		DISTRICT: 8	

REMOVE EXISTING
25 MPH SIGN & INSTALL
SL SIGN ON SAME PIPE

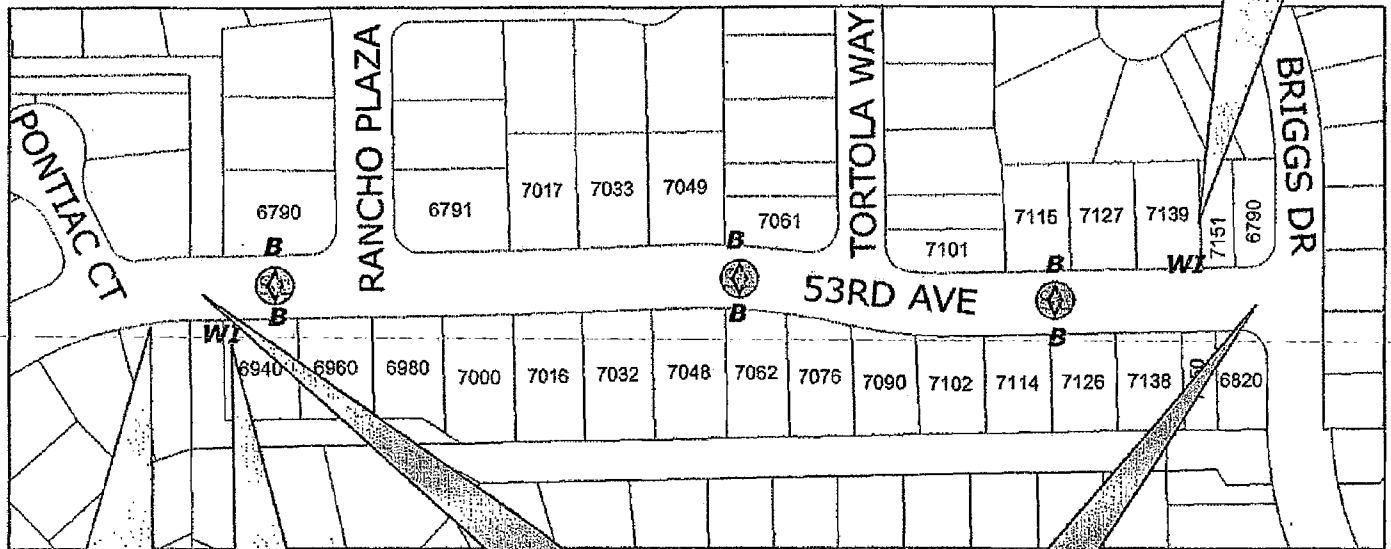

REMOVE EXISTING
25 MPH SIGN & PIPE

REMOVE 2 SPEED LEGENDS
AND 2 SIGNS AND 1 PIPE

REMOVE COUNTY'S END BIKEWAY SIGN
AND INSTALL SL SIGN ON POST



ON: 53RD AVENUE		
BETWEEN CITY LIMITS		
AND: BRIGGS DR		
DEVICE SPEED LUMP		
QTY.	WIDTH (ft)	
2	42'	
1	34'	
		BOLLARD: 6
		PADDLE:
		WARNING SIGN: 2
		2" PIPE: 1
		EXTENSION:
		ON ELECTROLIER:
PN: S1507138	NTMP: CAMELLIA	DISTRICT: 6

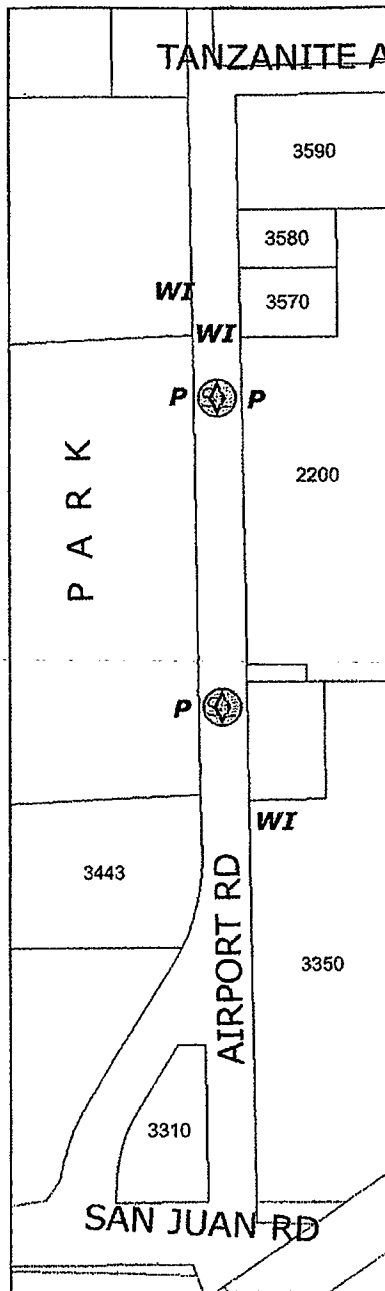

ON: AIRPORT ROAD			
BETWEEN TANZANITE AVE			
AND: SAN JUAN RD			
DEVICE SPEED LUMP			
QTY.	WIDTH (ft)	BOLLARD	
2	22	PADDLE:	3
		WARNING SIGN:	2
		2" PIPE:	2
		EXTENSION:	
		ON ELECTROLIER:	
PN: S15101200		NTMP:	DISTRICT: 1

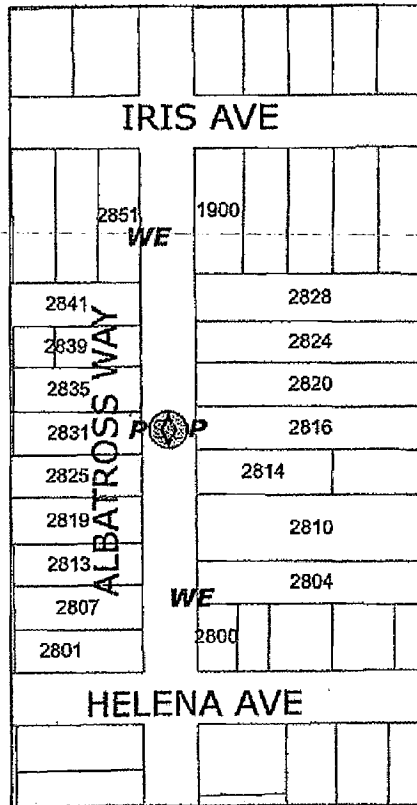

ON: ALBATROSS WAY (2)		
BETWEEN IRIS AVE		
AND: HELENA AVE		
DEVICE SPEED LUMP		
QTY.	WIDTH (ft)	
1	19	
		BOLLARD 1
		PADDLE: 2
		WARNING SIGN: 2
		2" PIPE: 1
		EXTENSION: 1
		ON ELECTROLIER: 2
PN: S15071149	NTMP: BEN ALI	DISTRICT: 3

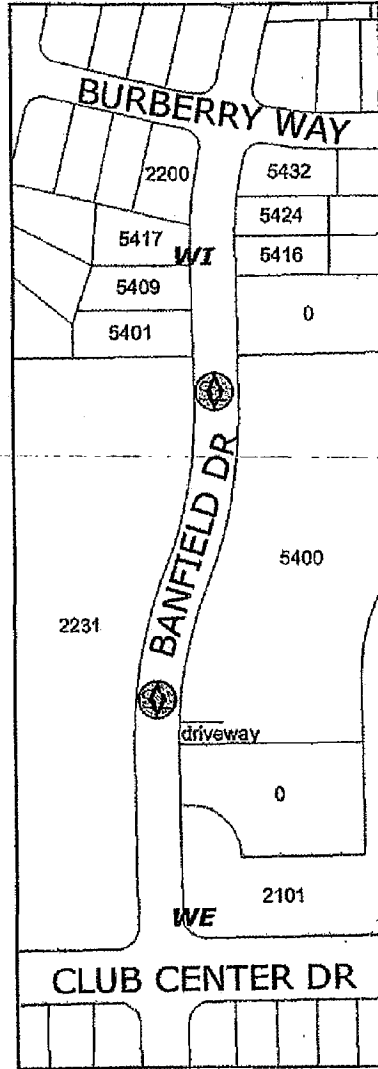

ON: BANFIELD DRIVE		
BETWEEN: BURBERRY WAY		
AND: CLUB CENTER DR		
DEVICE: SPEED LUMP		
QTY.	WIDTH (ft)	
2	35	
		BOLLARD:
		PADDLE:
		WARNING SIGN: 2
		2" PIPE: 1
		EXTENSION:
		ON ELECTROLIER: 1
PN: S15101105	NTMP: MEADOWS	DISTRICT: 1

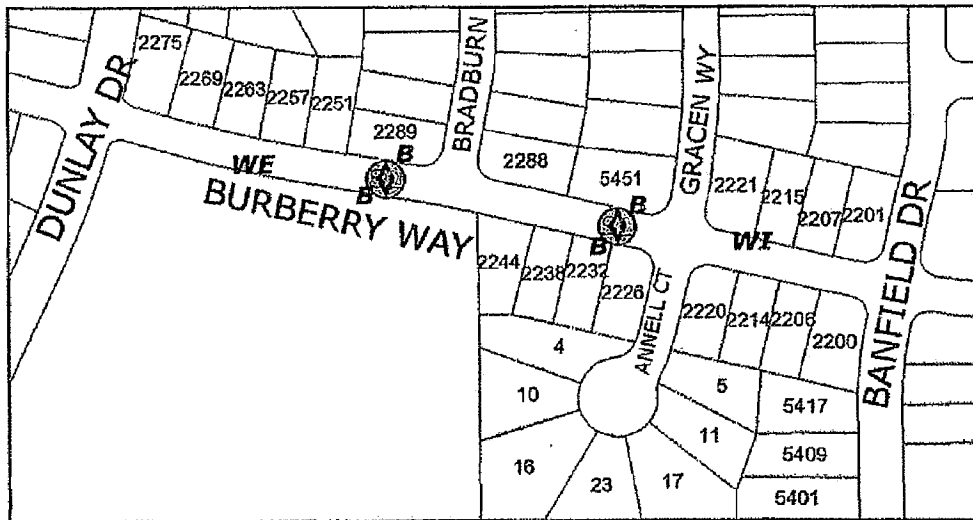

ON: BURBERRY WAY (2)		
BETWEEN DUNLAY DR		
AND: BANFIELD DR		
DEVICE SPEED LUMP		
QTY.	WIDTH (ft)	
2	25	
		BOLLARD 4
		PADDLE:
		WARNING SIGN: 2
		2" PIPE: 1
		EXTENSION:
		ON ELECTROLIER: 1
PN: S15101105	NTMP: MEADOWS	DISTRICT: 1

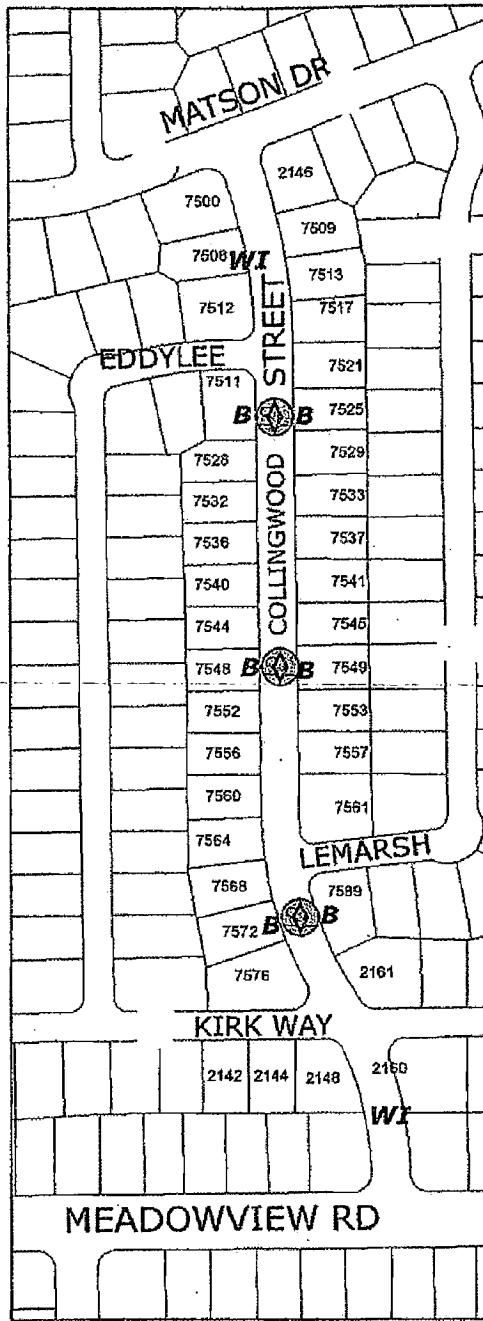

ON: COLLINGWOOD STREET

BETWEEN MATSON DR

AND: MEADOWVIEW RD

DEVICE: SPEED LUMP

QTY. WIDTH (ft)

3 36

BOLLARD: 6

PADDLE:

WARNING SIGN: 2

2" PIPE: 2

EXTENSION:

ON ELECTROLIER:

PN: S16071147

NTMP: VISTA

DISTRICT: 8

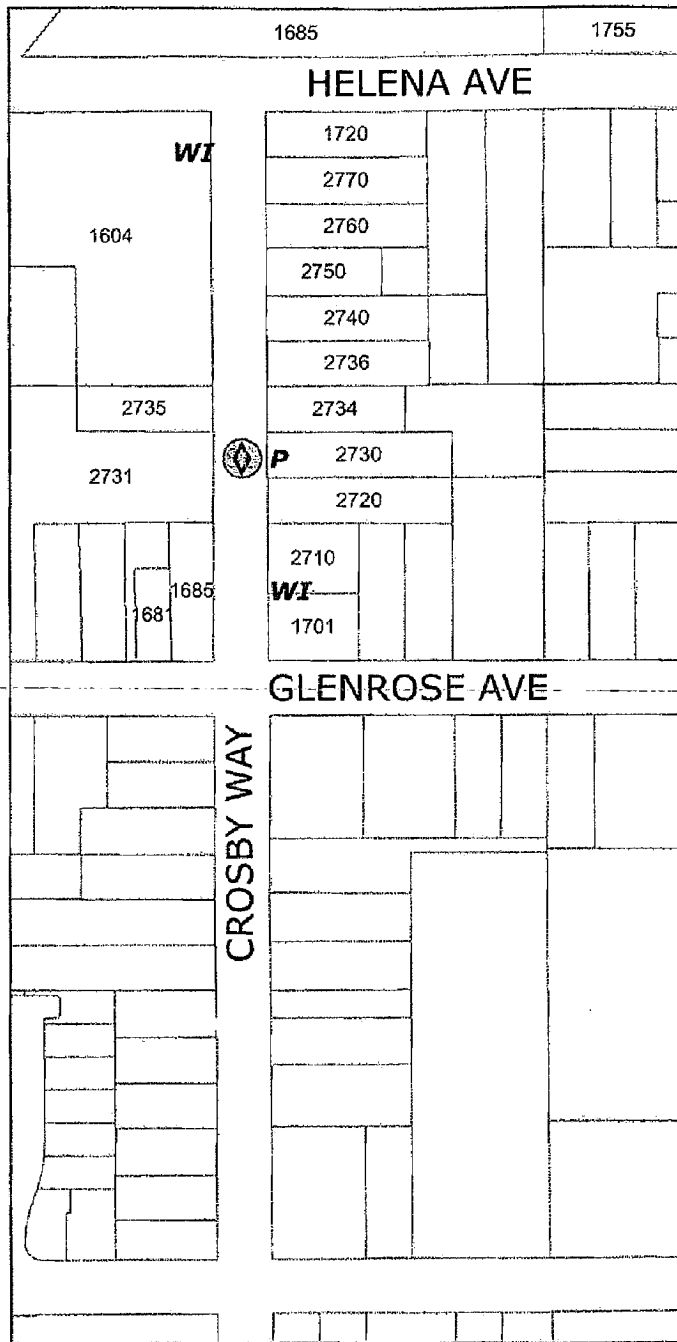

ON: CROSBY WAY (1)

BETWEEN HELENA AVE

AND: GLENROSE AVE

DEVICE SPEED LUMP

QTY. WIDTH (ft)

1 21

BOLLARD

PADDLE: 1

WARNING SIGN: 2

2" PIPE: 2

EXTENSION:

ON ELECTROLIER:

PN: S15071149

NTMP: BEN ALI

DISTRICT: 3

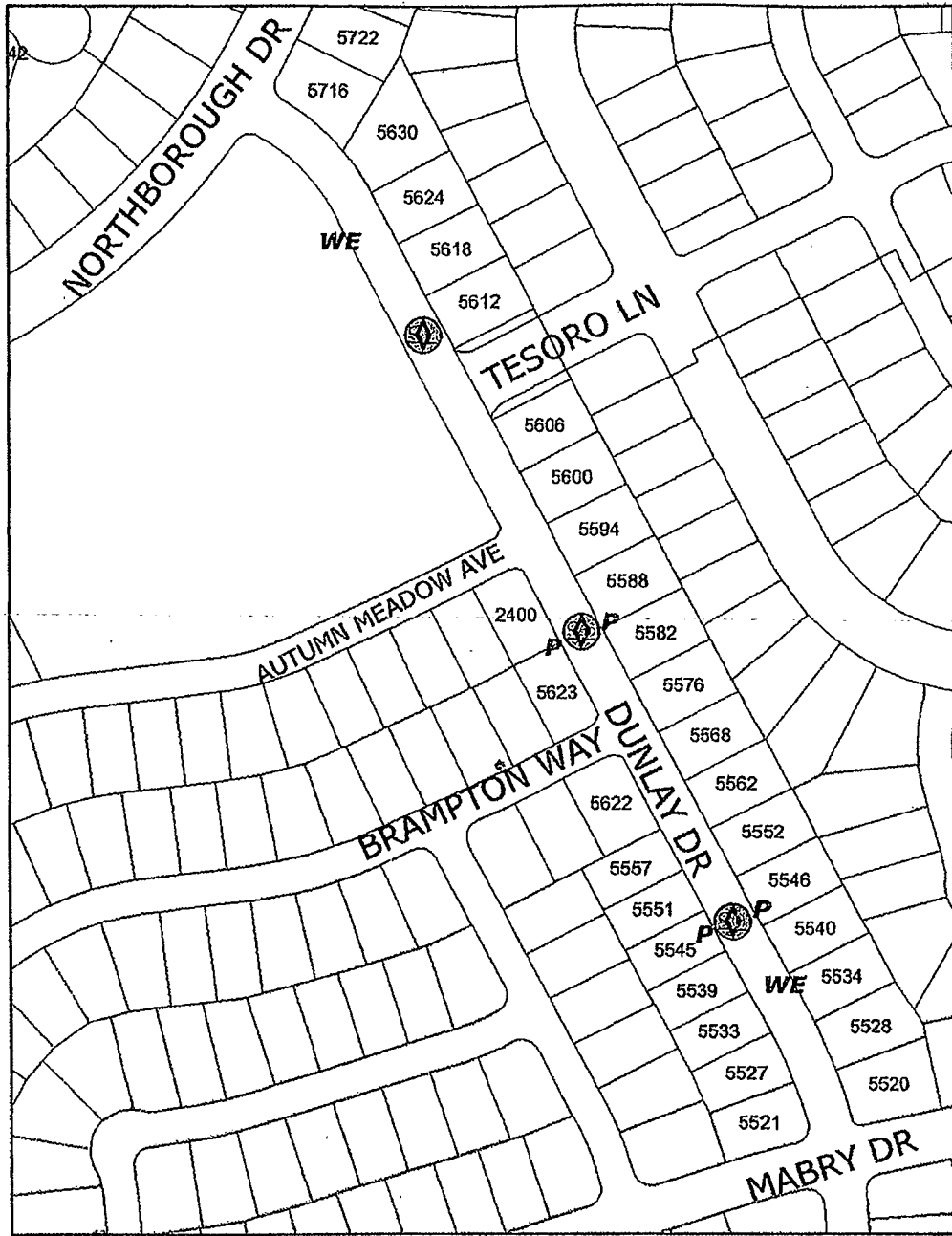

ON: DUNLAY DRIVE (1)

BETWEEN: NORTHBOROUGH DR

AND: MABRY DR

DEVICE: SPEED LUMP

QTY. **WIDTH (ft)**

3	25

BOLLARD:

PADDLE: 4

WARNING SIGN: 2

2" PIPE:

EXTENSION:

ON ELECTROLIER: 2

PN: S15101105

NTMP: MEADOWS

DISTRICT: 1

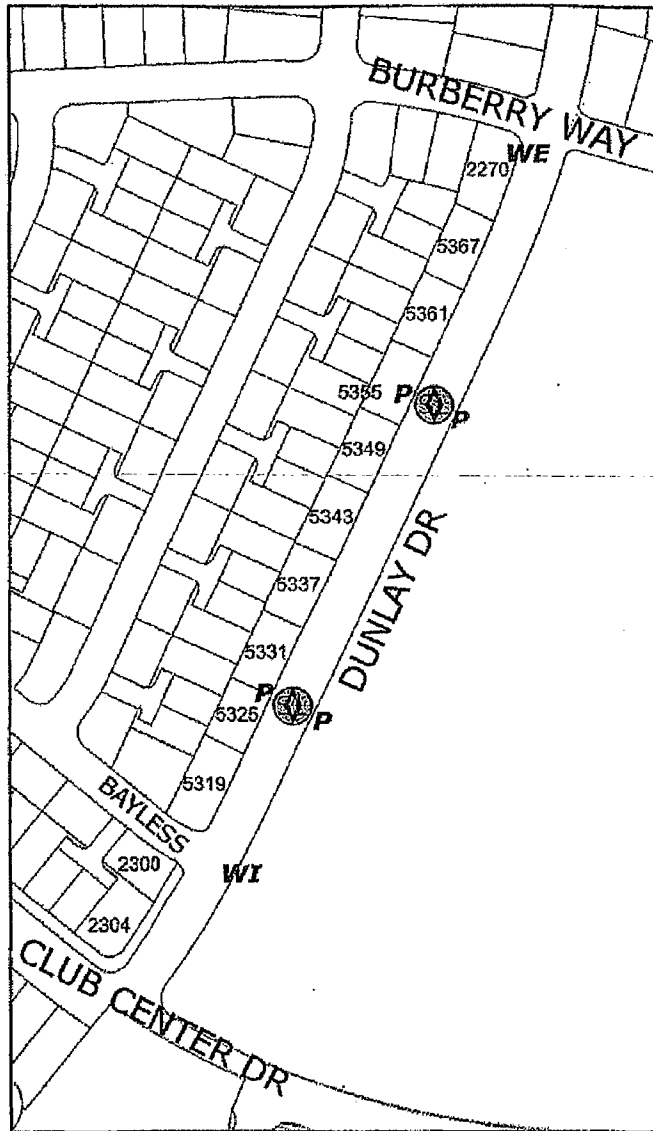

ON: DUNLAY DRIVE (3)			
BETWEEN BURBERRY WAY			
AND: CLUB CENTER DR			
DEVICE: SPEED LUMP			
QTY.	WIDTH (ft)	BOLLARD	4
2	25	PADDLE:	
		WARNING SIGN:	2
		2" PIPE:	1
		EXTENSION:	
		ON ELECTROLIER:	1
PN: S15101105	NTMP: MEADOWS	DISTRICT:	1

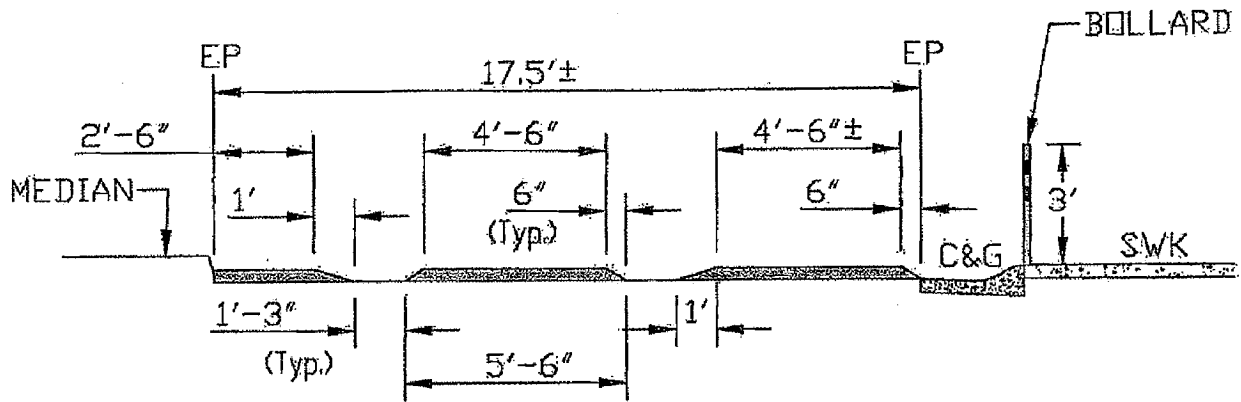

SPEED LUMP DETAIL FOR THIS SEGMENT

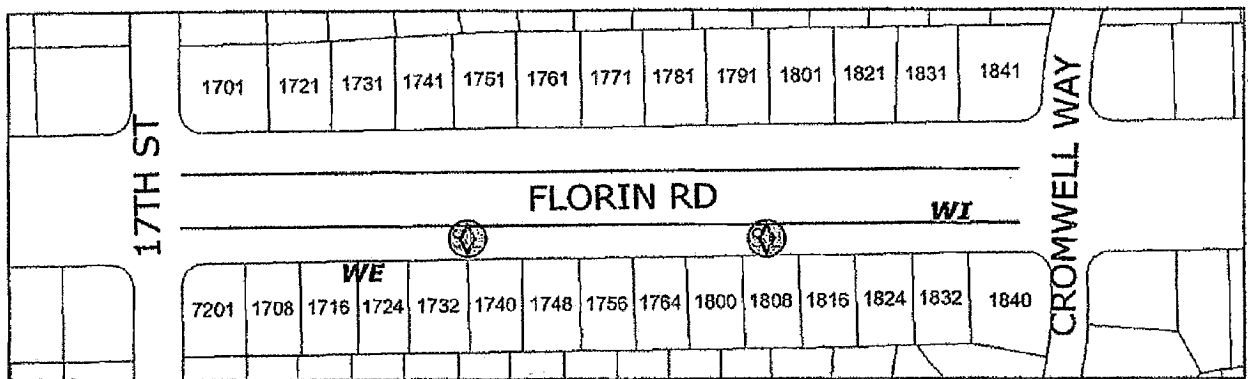

B
P
WI
WX



ON: FLORIN FRONTAGE RD. S (2)			
BETWEEN 17TH ST			
AND: CROMWELL WAY			
DEVICE SPEED LUMP			
QTY.	WIDTH (ft)	BOLLARD	2
2	18	PADDLE:	
		WARNING SIGN:	2
		2" PIPE:	1
		EXTENSION:	
		ON ELECTROLIER:	1
PN: S15071146	NTMP: WILLOW RANCHO	DISTRICT:	8

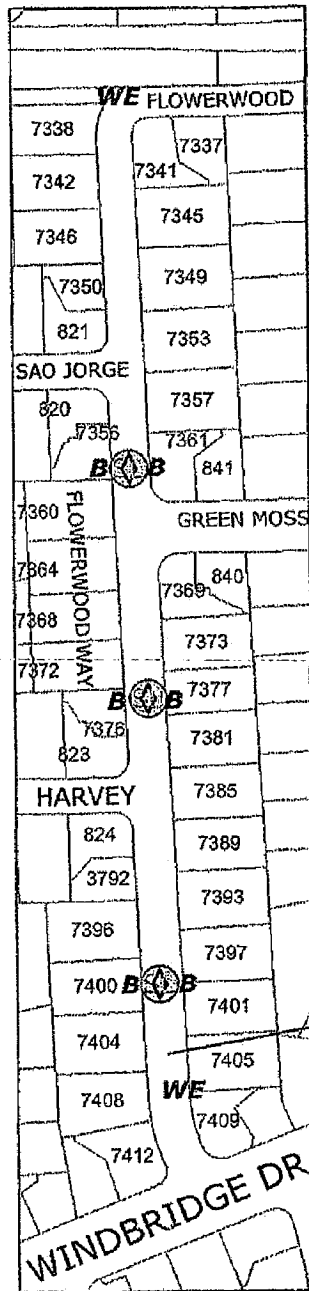

ON: FLOWERWOOD WAY			
BETWEEN NELBOW			
AND: WINDBRIDGE DR			
DEVICE SPEED LUMP			
QTY.	WIDTH (ft)	BOLLARD	6
3	25	PADDLE:	
		WARNING SIGN:	2
		2" PIPE:	1
		EXTENSION:	
		ON ELECTROLIER:	1
PN: S15101200		NTMP:	DISTRICT: 7

REMOVE R2 & PIPE

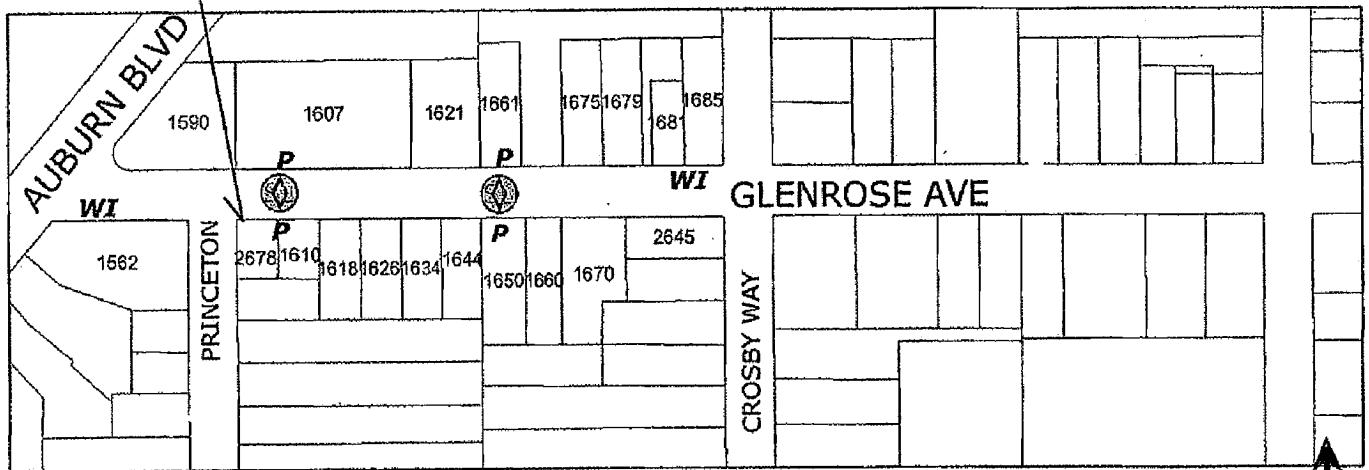

ON: GLENROSE AVENUE (1)		BOLLARD
BETWEEN AUBURN BLVD		PADDLE: 4
AND: CROSBY WAY		WARNING SIGN: 2
DEVICE SPEED LUMP		2" PIPE: 2
QTY.	WIDTH (ft)	EXTENSION:
2	21	ON ELECTROLIER:
PN: S15071149	NTMP: BEN ALI	DISTRICT: 3

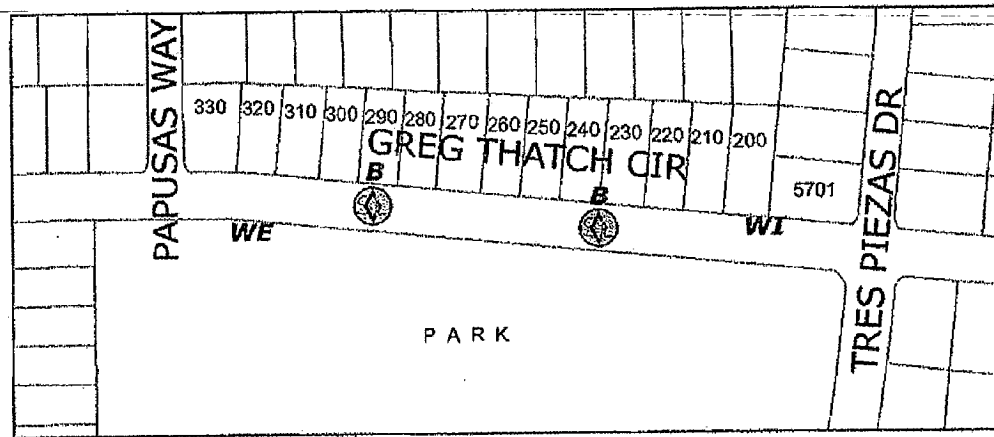

ON: GREG THATCH CIRCLE		
BETWEEN PAMPUSAS WAY		
AND: TRES PEIZAS DR		
DEVICE SPEED LUMP		
QTY.	WIDTH (ft)	
2	35	
		BOLLARD: 2
		PADDLE: 1
		WARNING SIGN: 2
		2" PIPE: 1
		EXTENSION: 1
		ON ELECTROLIER: 1
PN: S15101200	NTMP:	DISTRICT: 1

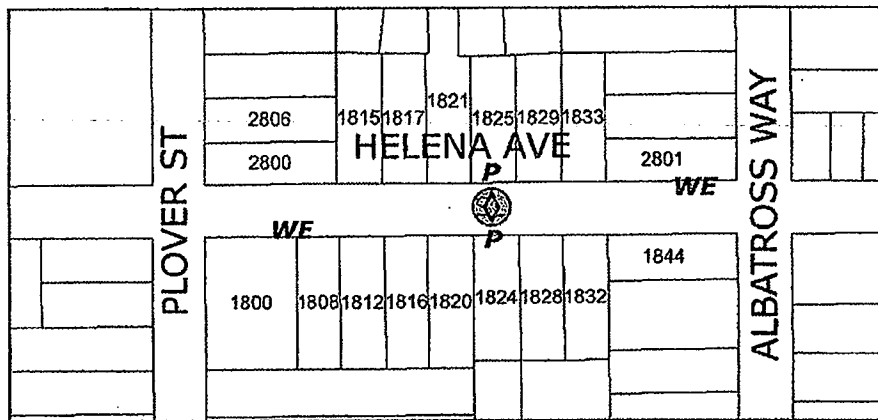

ON: HELENA AVENUE (2)

BETWEEN PLOVER ST

AND: ALBATROSS WAY

DEVICE SPEED LUMP

QTY. WIDTH (ft)

1 21

BOLLARD

PADDLE: 2

WARNING SIGN: 2

2" PIPE:

EXTENSION:

ON ELECTROLIER: 2

PN: S15071149

NTMP: BEN ALI

DISTRICT: 3

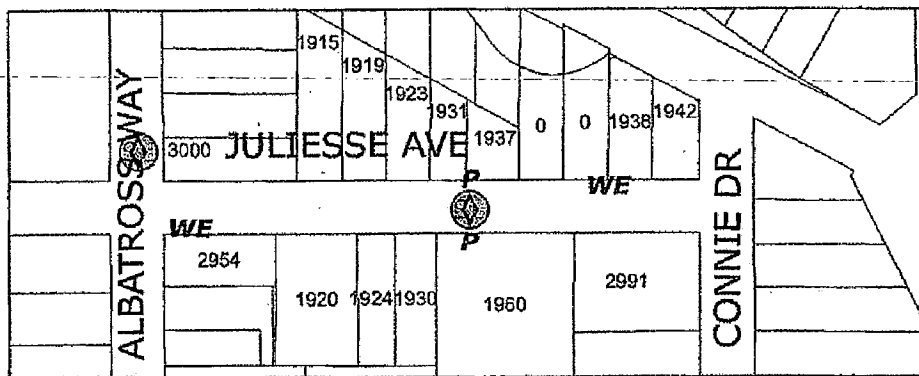

ON: JULIESSE AVENUE		
BETWEEN ALBATROSS WAY		
AND: CONNIE DR		
DEVICE SPEED LUMP		
QTY.	WIDTH (ft)	
1	19	
		BOLLARD
		PADDLE: 2
		WARNING SIGN: 2
		2" PIPE:
		EXTENSION:
		ON ELECTROLIER: 2
PN: S15071149		NTMP: BEN ALI
		DISTRICT: 3

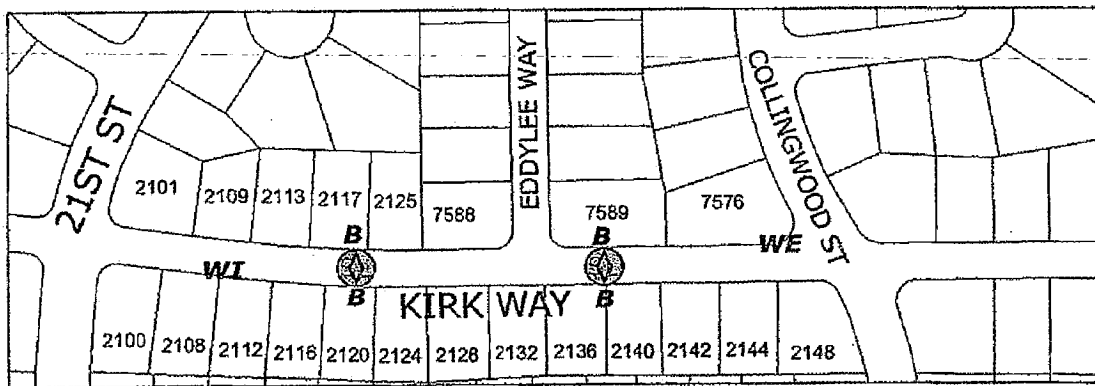

ON: KIRK WY (1)		
BETWEEN 21ST ST		
AND: COLLINGWOOD ST		
DEVICE SPEED LUMP		
QTY.	WIDTH (ft)	
2	25	
		BOLLARD 4
		PADDLE:
		WARNING SIGN: 2
		2" PIPE: 1
		EXTENSION:
		ON ELECTROLIER: 1
PN: S15101200	NTMP:	DISTRICT: 8

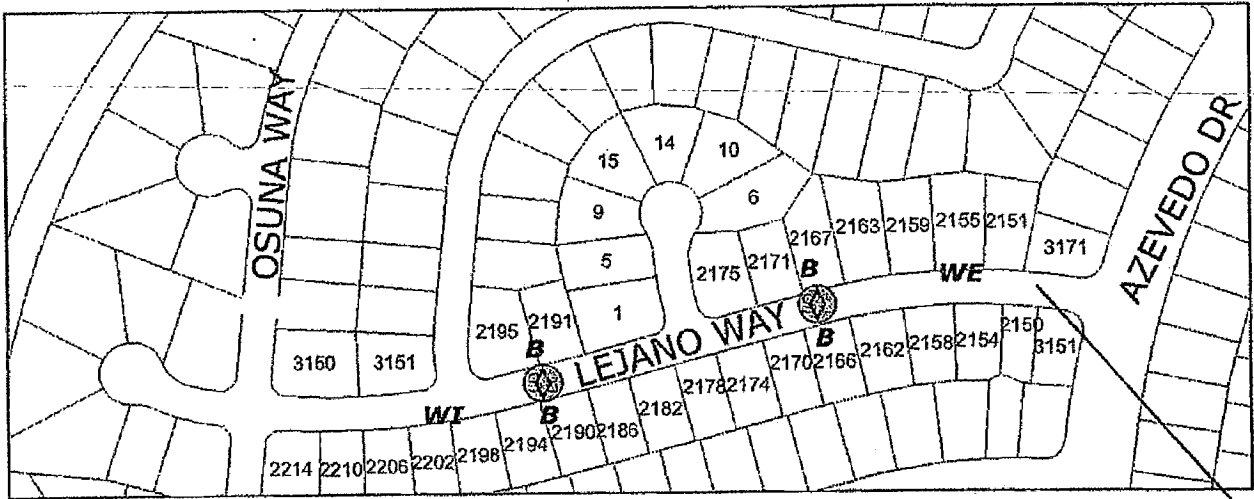

REMOVE SPEED LEGEND



ON: LEJANO WAY		BOLLARD: 4	
BETWEEN OSUNA WAY		PADDLE:	
AND: AZEVEDO DR		WARNING SIGN: 2	
DEVICE SPEED LUMP		2" PIPE: 1	
QTY.	WIDTH (ft)	EXTENSION:	
2	25	ON ELECTROLIER: 1	
PN: S15101200		DISTRICT: 1	
NTMP:			

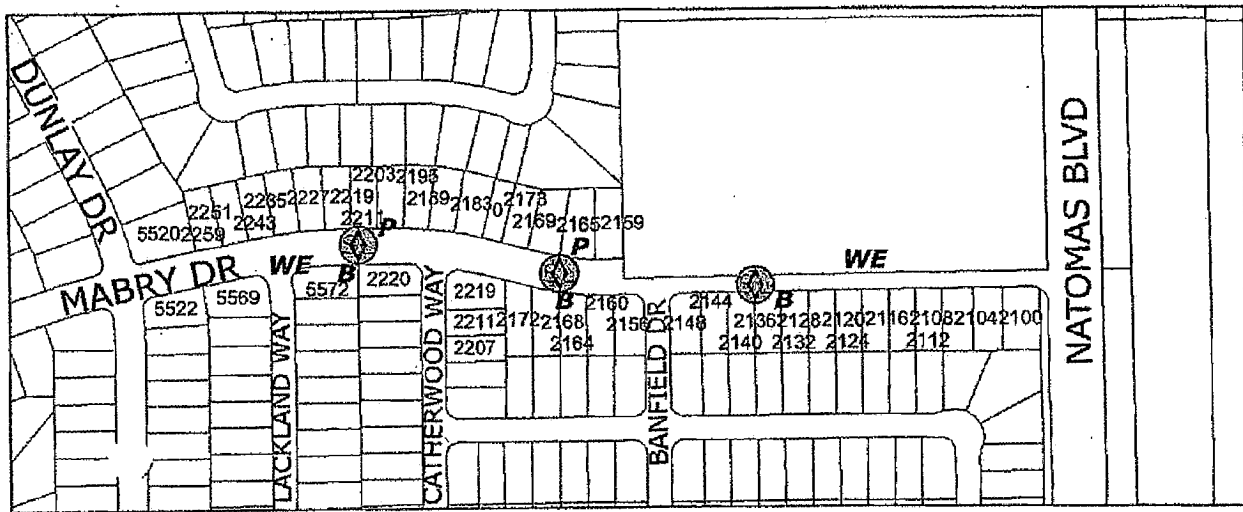

WI
WX



ON: MABRY DRIVE (2)		
BETWEEN DUNLAY DR		
AND: NATOMAS BLVD		
DEVICE SPEED LUMP		
QTY.	WIDTH (ft)	
3	41	
		BOLLARD 3
		PADDLE: 2
		WARNING SIGN: 2
		2" PIPE: []
		EXTENSION: []
		ON ELECTROLIER: 2
PN: S15101105	NTMP: MEADOWS	DISTRICT: []

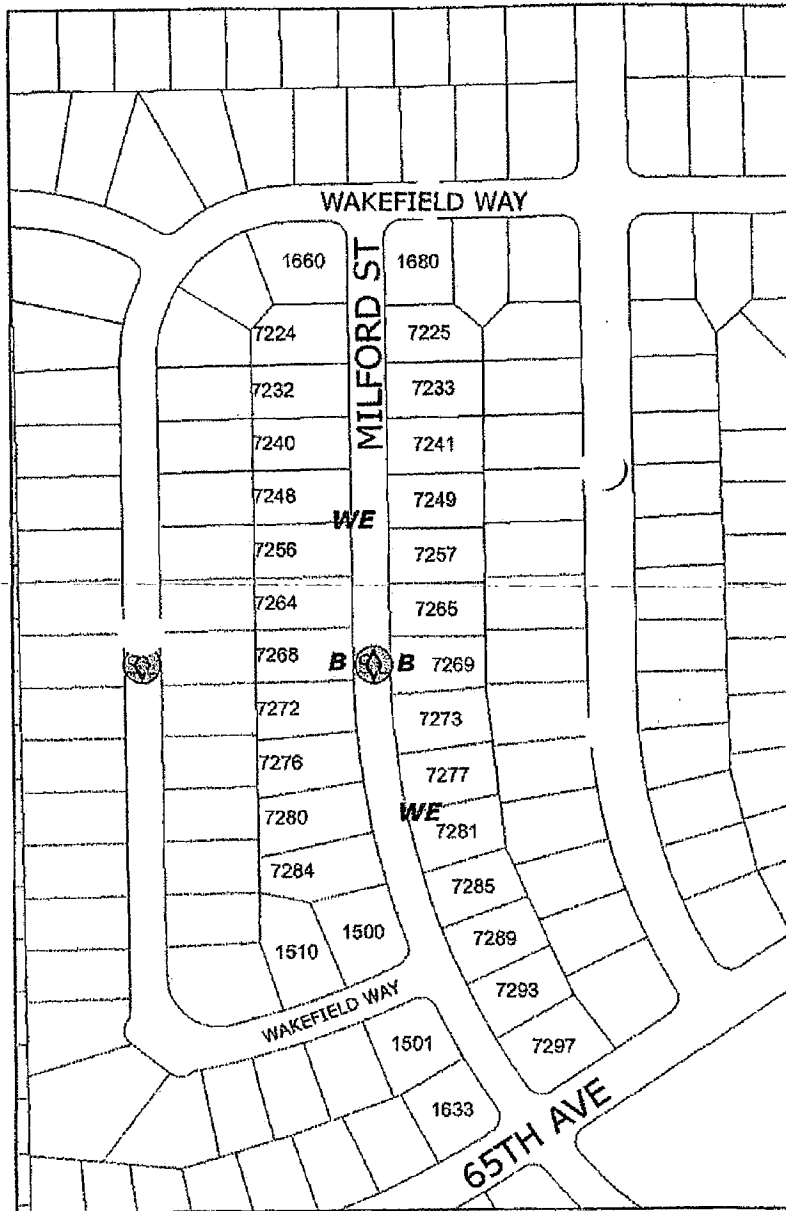

ON: MILFORD STREET		BOLLARD 2	
BETWEEN WAKEFIELD WAY		PADDLE:	
AND: 65TH AVE		WARNING SIGN: 2	
DEVICE SPEED LUMP		2" PIPE:	
QTY.	WIDTH (ft)	EXTENSION:	
1	25	ON ELECTROLIER: 2	
PN: S15071146		NTMP: WILLOW RANCHO	
		DISTRICT: 8	

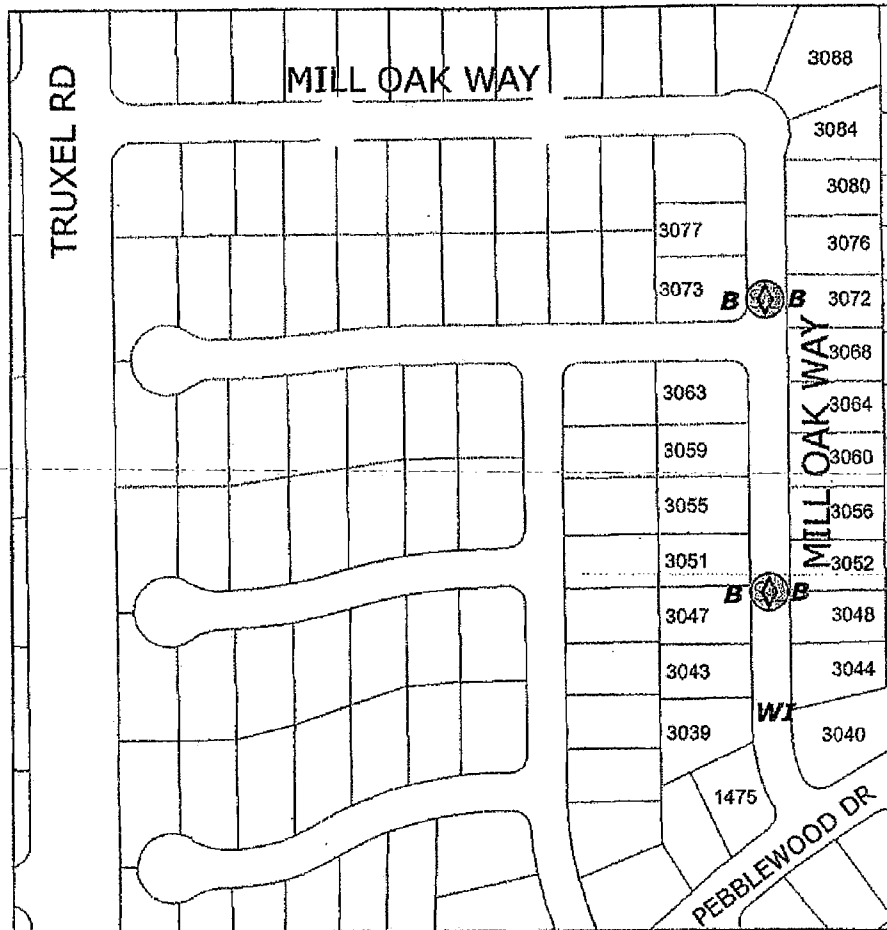

SEE ALSO MILL OAK WAY (1) MAP



ON: MILL OAK WAY (2)		BOLLARD 4	
BETWEEN E CURVE		PADDLE:	
AND: PEBBLEWOOD DR		WARNING SIGN: 1	
DEVICE SPEED LUMP		2" PIPE: 1	
QTY.	WIDTH (ft)	EXTENSION:	
2	25	ON ELECTROLIER:	
PN: S15101200		NTMP:	
DISTRICT:			

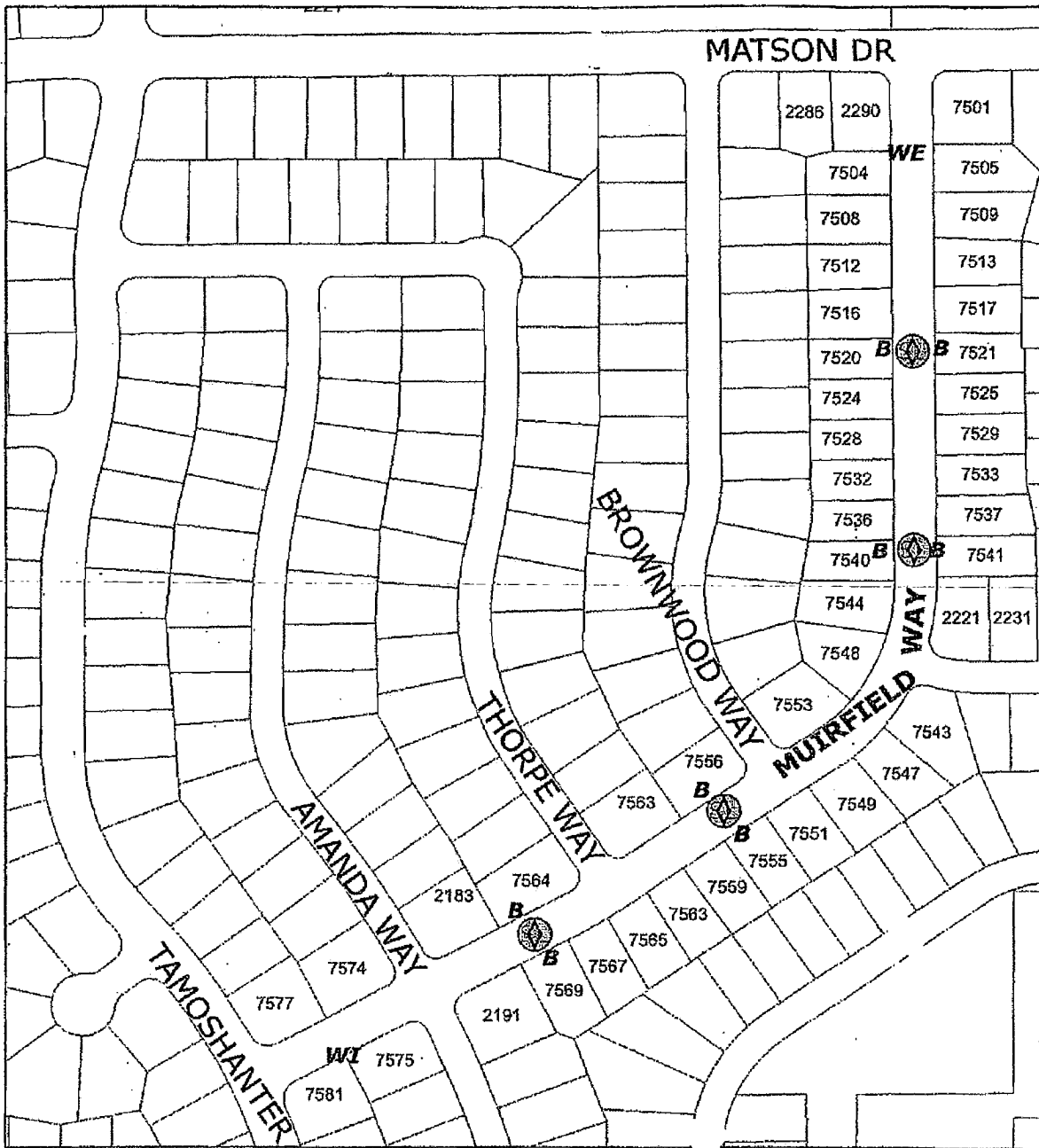

ON: MUIRFIELD WAY		BOLLARD 8	
BETWEEN MATSON DR		PADDLE:	
AND: TAMOSHANTER WAY		WARNING SIGN: 2	
DEVICE SPEED LUMP		2" PIPE: 1	
QTY.	WIDTH (ft)	EXTENSION:	
4	35	ON ELECTROLIER: 1	
PN: S15071147		NTMP: VISTA	
		DISTRICT: 8	

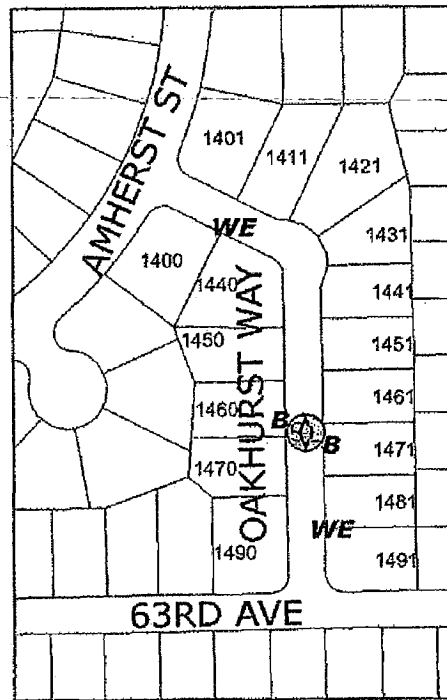

ON: OAKHURST WAY		
BETWEEN AMHERST ST		
AND: 63RD AVE		
DEVICE SPEED LUMP		
QTY.	WIDTH (ft)	
1	25	
		BOLLARD: 2
		PADDLE:
		WARNING SIGN: 2
		2" PIPE:
		EXTENSION:
		ON ELECTROLIER: 2
PN: S15071146	NTMP: WILLOW RANCHO	DISTRICT: 8

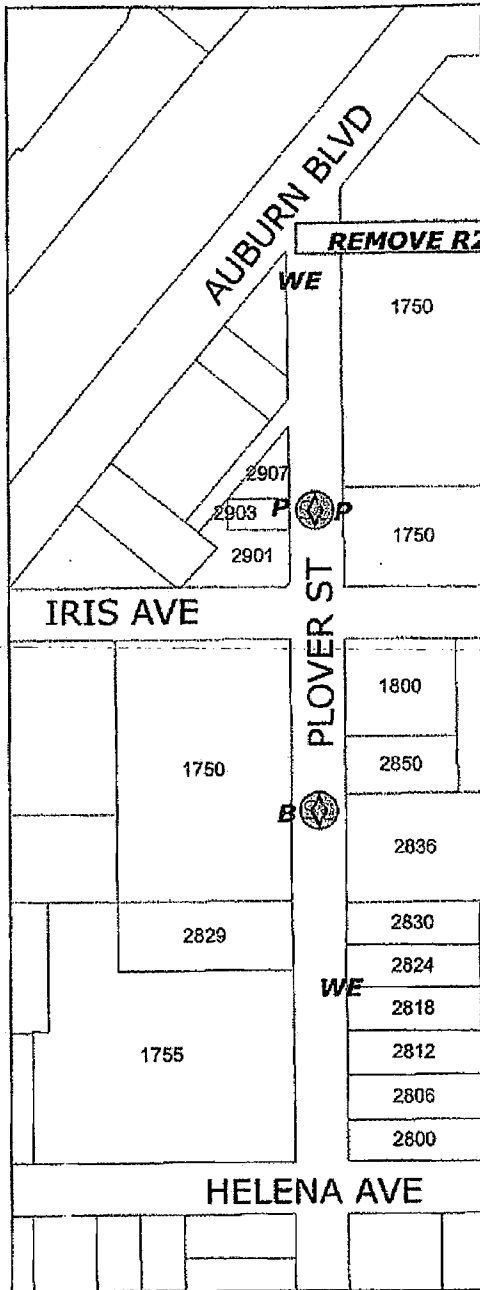

ON: PLOVER STREET (1)			
BETWEEN AUBURN BLVD			
AND: HELENA AVE			
DEVICE SPEED LUMP			
QTY.	WIDTH (ft)	BOLLARD	1
1	21	PADDLE	2
1	29	WARNING SIGN	2
		2" PIPE	
		EXTENSION	
		ON ELECTROLIER	2
PN: S15071149		DISTRICT: 3	
NTMP: BEN ALI			

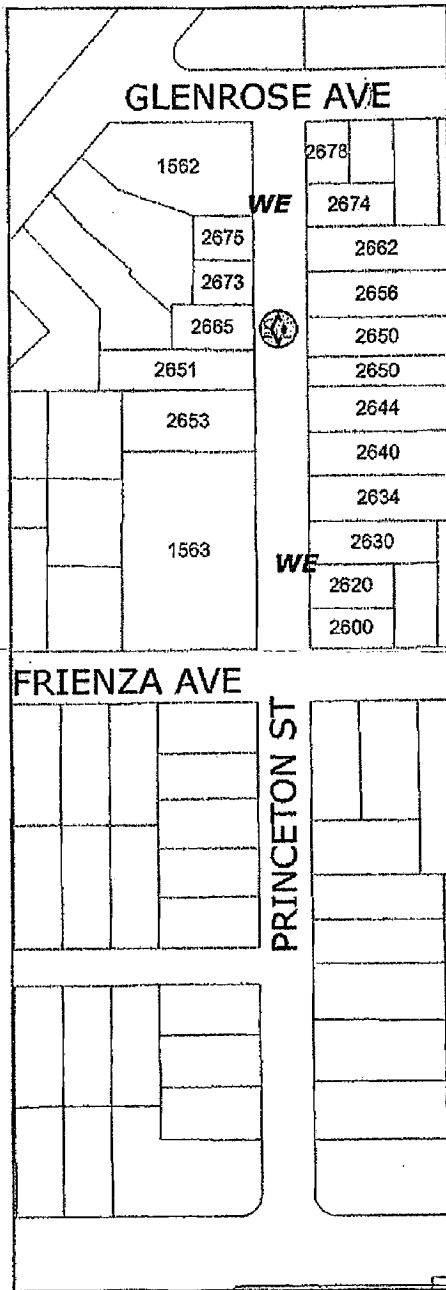

ON: PRINCETON STREET (1)		BOLLARD
BETWEEN GLENROSE AVE		PADDLE:
AND: FRIENZA AVE		WARNING SIGN: 2
DEVICE SPEED LUMP		2" PIPE:
QTY.	WIDTH (ft)	EXTENSION:
1	26	ON ELECTROLIER: 2
PN: S15071149		DISTRICT: 3
NTMP: BEN ALI		

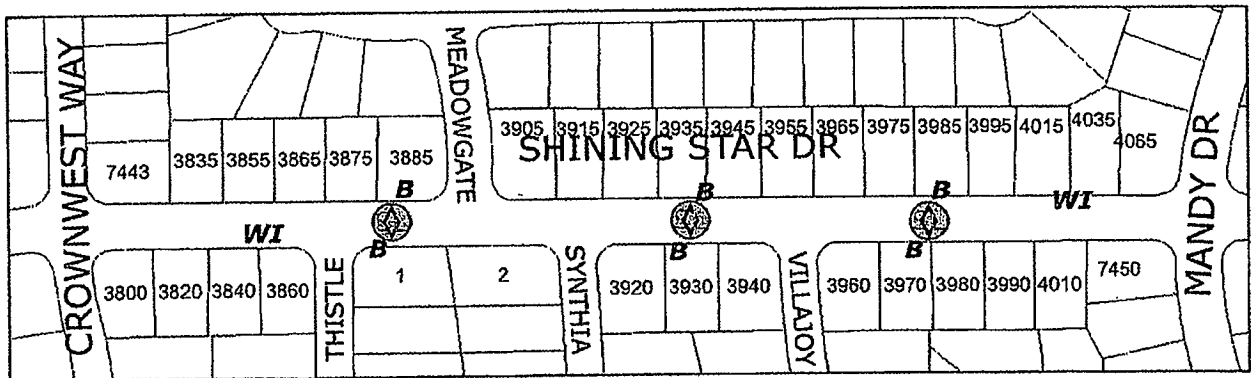

ON: SHINING STAR (1)		
BETWEEN CROWN WEST WAY		
AND: MANDY DR		
DEVICE SPEED LUMP		
QTY.	WIDTH (ft)	
3	35	
		BOLLARD 6
		PADDLE:
		WARNING SIGN: 2
		2" PIPE: 2
		EXTENSION:
		ON ELECTROLIER:
PN: S15071148	NTMP: VILLAGE PARK	DISTRICT: 8

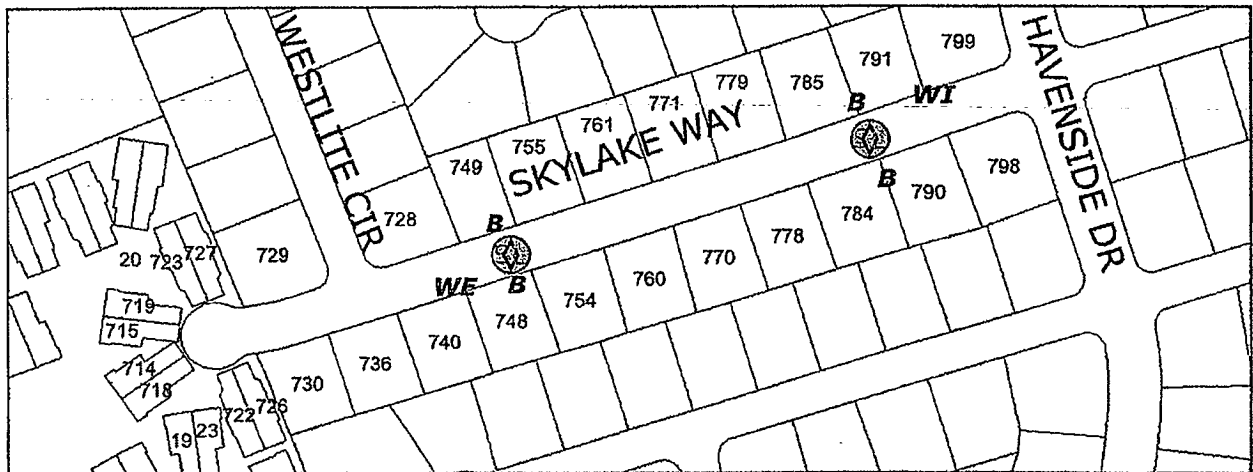

ON: SKYLAKE WAY			
BETWEEN: END			
AND: HAVENSIDE DR			
DEVICE: SPEED LUMP			
QTY.	WIDTH (ft)	BOLLARD	4
2	35	PADDLE:	
		WARNING SIGN:	2
		2" PIPE:	1
		EXTENSION:	
PN: S15101200	NTMP:	ON ELECTROLIER:	1
		DISTRICT:	7

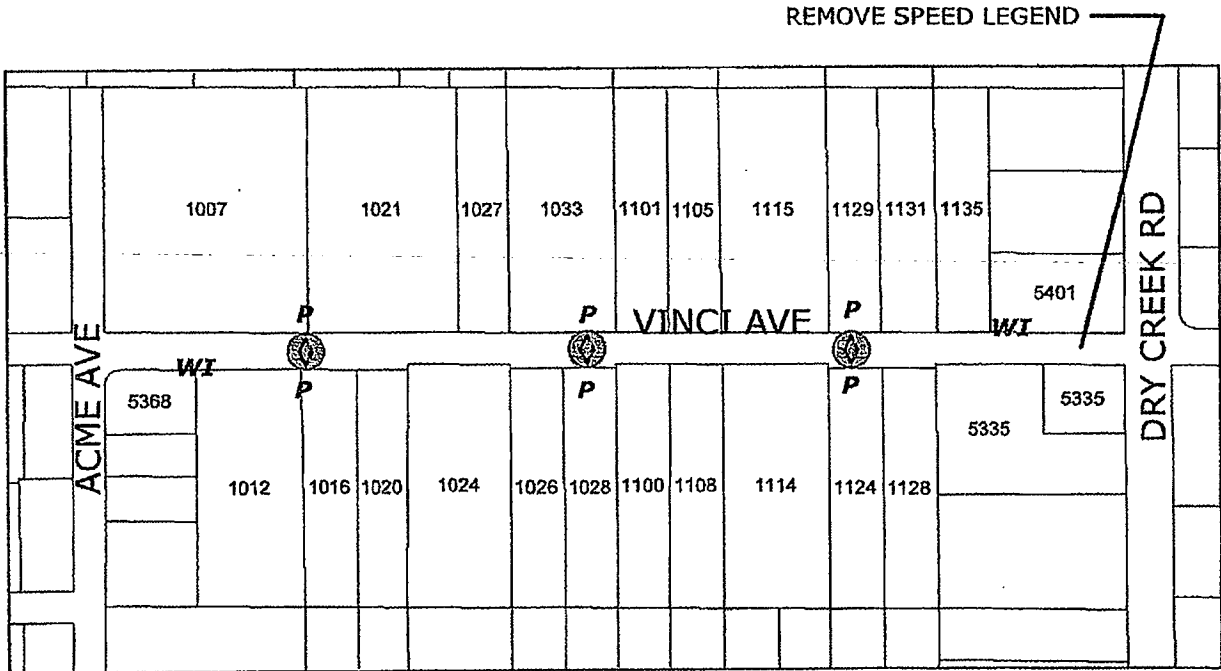
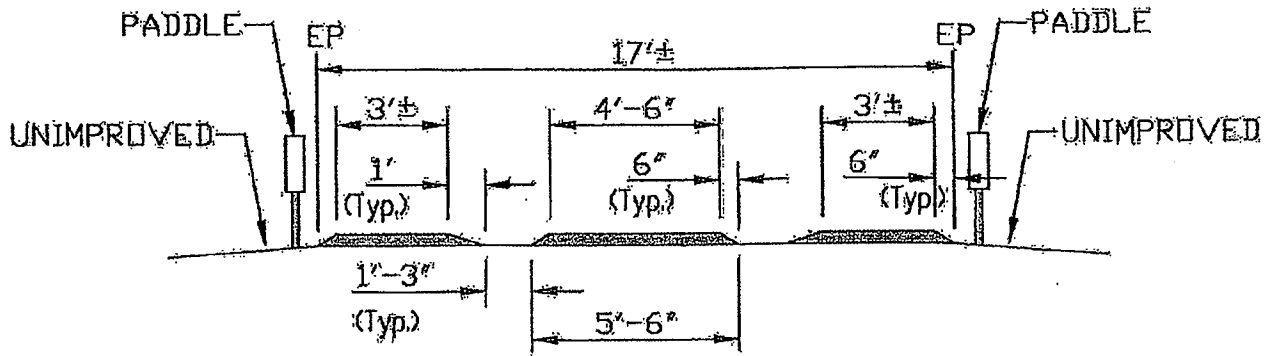

ON: VINCI AVENUE			
BETWEEN: ACME AVE			
AND: DRY CREEK RD			
DEVICE: SPEED LUMP			
QTY.	WIDTH (ft)	BOLLARD:	
3	17	PADDLE:	6
		WARNING SIGN:	2
		2" PIPE:	2
		EXTENSION:	
		ON ELECTROLIER:	
PN: S15101200		NTMP:	DISTRICT: 2

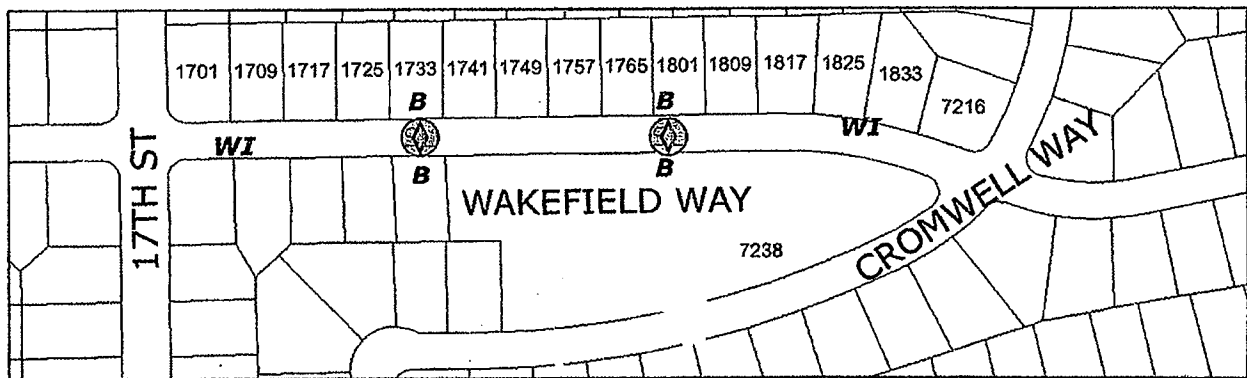

ON: WAKEFIELD WAY (2)		
BETWEEN 17TH ST		
AND: CROMWELL WAY		
DEVICE SPEED LUMP		
QTY.	WIDTH (ft)	
2	25	
		BOLLARD 4
		PADDLE:
		WARNING SIGN: 2
		2" PIPE: 2
		EXTENSION:
		ON ELECTROLIER:
PN: S15101200	NTMP:	DISTRICT: 8

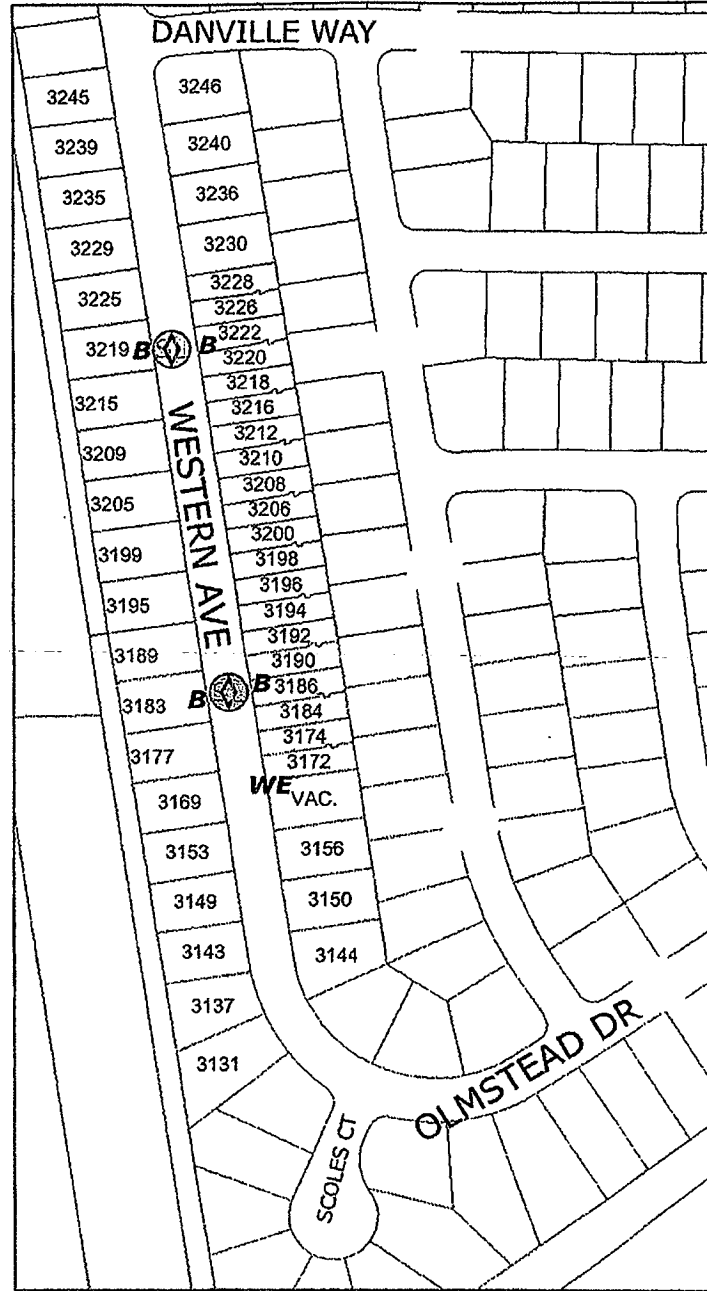
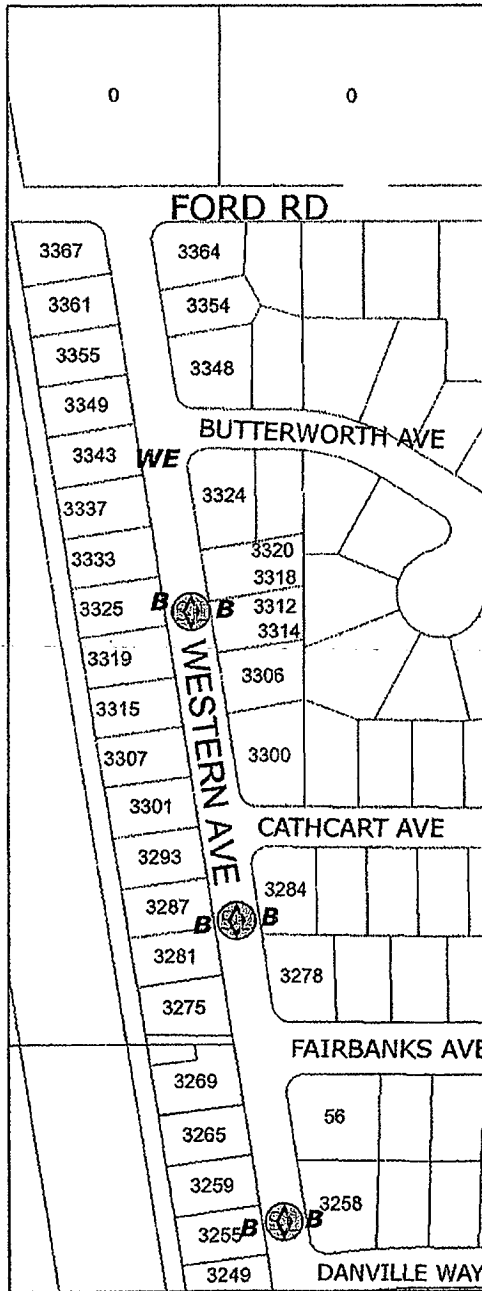

ON: WESTERN AVENUE

BETWEEN FORD RD

AND: OLMSTEAD DR

DEVICE SPEED LUMP

QTY. WIDTH (ft)

5 36

BOLLARD 10

PADDLE:

WARNING SIGN: 2

2" PIPE:

EXTENSION:

ON ELECTROLIER: 2

PN: S15101200

NTMP:

DISTRICT: 2

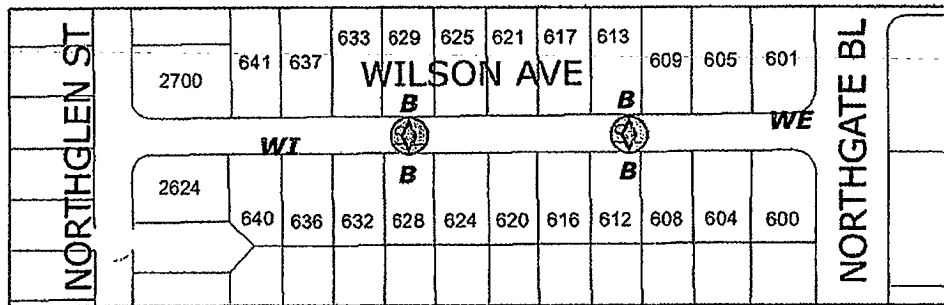

ON: WILSON AVENUE		
BETWEEN NORTHGLEN ST		
AND: NORTHGATE BL		
DEVICE SPEED LUMP		
QTY.	WIDTH (ft)	
2	26	
		BOLLARD: 4
		PADDLE:
		WARNING SIGN: 2
		2" PIPE: 1
		EXTENSION:
		ON ELECTROLIER: 1
PN: S15101200		DISTRICT: 1
NTMP:		

EXHIBIT C

Location	Between These Streets	Tables	Width	TB Guide
Innovator Drive	Prosper Rd/Endeavor Wy	3	40	277-B2

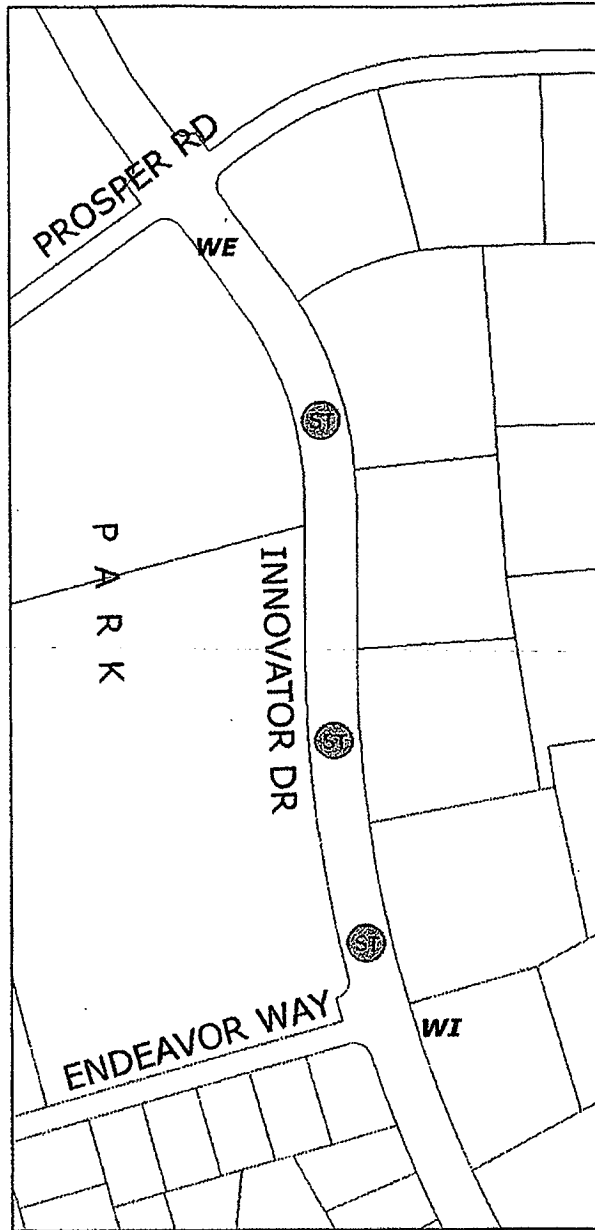

ON: INNOVATOR DRIVE

BETWEEN PROSPER RD

AND: ENDEAVOR WY

DEVICE SPEED TABLE

QTY. WIDTH (ft)

3 40

BOLLARD

PADDLE:

WARNING SIGN: 2

2" PIPE: 1

EXTENSION:

ON ELECTROLIER: 1

PN: S15101200

NTMP:

DISTRICT: 1