

CITY OF SACRAMENTO

1231 I Street, Sacramento, CA 95814

Permit No: 0313808

Insp Area: 3
Thos Bros: 317 F1

Site Address: 3200 5TH AV SAC
Parcel No: 013-0136-015

Sub-Type: NOTHR
Housing (Y/N): N

CONTRACTOR
GPS SPECIALTY CONSTRUCTION
203 B KENROY LN
ROSEVILLE CA 95678

OWNER
UNIVERSITY OF THE PACIFIC
3200 5TH AV
SACRAMENTO CA 95817

ARCHITECT

Nature of Work: 8 FLAG POLES/15 FEET HGT

CONSTRUCTION LENDING AGENCY: I hereby affirm under penalty of perjury that there is a construction lending agency for the performance of the work for which this permit is issued (Sec. 3097, Civ. C).

Lender's Name Lender's Address

LICENSED CONTRACTORS DECLARATION: I hereby affirm under penalty of perjury that I am licensed under provisions of Chapter 9 (commencing with section 7000) of Division 3 of the Business and Professions Code and my license is in full force and effect.

License Class B License Number 731185 Date 9/11/03 Contractor Signature [Signature]

OWNER-BUILDER DECLARATION: I hereby affirm under penalty of perjury that I am exempt from the contractors License Law for the following reason (Sec. 7031.5, Business and Professions Code; any city or county which requires a permit to construct, alter, improve, demolish, or repair any structure, prior to its issuance, also requires the applicant for such permit to file a signed statement that he or she is licensed pursuant to the provisions of the Contractors License Law (Chapter 9 (commencing with Section 7000) of Division 8 of the Business and Professions Code) or that he or she is exempt therefrom and the basis for the alleged exemption. Any violation of Section 7031.5 by any applicant for a permit subjects the applicant to a civil penalty of not more than five hundred dollars (\$500.00);

I, as a owner of the property, or my employees with wages as their sole compensation, will do the work, and the structure is not intended or offered for sale (Sec. 7044, Business and Professional Code: The Contractors License Law does not apply to an owner of property who builds or improves thereon, and who does such work himself or herself or through his/her own employees, provided that such improvements are not intended or offered for sale. If, however, the building or improvement is sold within one year of completion, the owner-builder will have the burden of proving that he/she did not build or improve for the purpose of sale.)

I, as owner of the property, am exclusively contracting with licensed contractors to construct the project (Sec. 7044, Business and Professions Code: The Contractors License Law does not apply to an owner of property who builds or improves thereon and who contracts for such projects with a contractor(s) licensed pursuant to the Contractors License Law).

I am exempt under Sec. B & PC for this reason:
Date Owner Signature

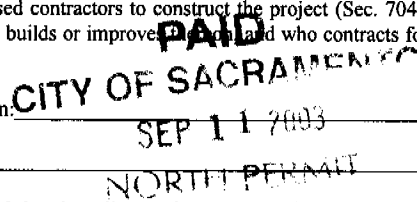

IN ISSUING THIS BUILDING PERMIT, the applicant represents, and the city relies on the representation of the applicant, that the applicant verified all measurements and locations shown on the application or accompanying drawings and that the improvement to be constructed does not violate any law or private agreement relating to permissible or prohibited locations for such improvements. This building permit does not authorize any illegal location of any improvement or the violation of any private agreement relating to location of improvements.

I certify that I have read this application and state that all information is correct. I agree to comply with all city and county ordinances and state laws relating to building construction and hereby authorize representative(s) of this city to enter upon the abovementioned property for inspection purposes.

Date 9/11/03 Applicant/Agent Signature [Signature]

WORKER'S COMPENSATION DECLARATION: I hereby affirm under penalty of perjury one of the following declarations:
I have and will maintain a certificate of consent to self-insure for workers' compensation as provided for by Section 3700 of the Labor Code, for the performance of work for which the permit is issued.

X I have and will maintain workers' compensation insurance, as required by Section 3700 of the Labor Code, for the performance of the work for which this permit is issued. My workers' compensation insurance carrier and policy number are:

Carrier STATE FUND Policy Number 692-00 UNIT 0002284 Exp Date 10/01/2003

(This section need not be completed if the permit is for \$100 or less) I certify that in the performance of the work for which this permit is issued, I shall not employ any person in any manner so as to become subject to the workers' compensation laws of California and agree that if I should become subject to the workers' compensation provisions of Section 3700 of the Labor Code, I shall forthwith comply with those provisions.

Date 9/11/03 Applicant Signature [Signature]

WARNING: FAILURE TO SECURE WORKER'S COMPENSATION COVERAGE IS UNLAWFUL AND SHALL SUBJECT AN EMPLOYER TO CRIMINAL PENALTIES AND CIVIL FINES UP TO ONE HUNDRED THOUSAND DOLLARS (\$100,000) IN ADDITION TO THE COST OF COMPENSATION, DAMAGES AS PROVIDED FOR IN SECTION 3706 OF THE LABOR CODE, INTEREST AND ATTORNEY'S FEE.

THIS PERMIT SHALL EXPIRE BY LIMITATION IF WORK IS NOT COMMENCED WITHIN 180 DAYS.

APPLICATION FOR COMMERCIAL BUILDING PERMIT

CITY OF SACRAMENTO
PLANNING & BUILDING DEPARTMENT
 1231 I Street, Suite 200 or 2101 Arena Bl., 200
 Sacramento, CA 95814 Sacramento, CA 95834
 (916) 264-5656, 1-866 EZ PERMIT or www.cityofsacramento.org

ACTIVITY # 03	Insp. Area
-------------------------	-------------------

Applicant to complete all areas down to valuation

ADDRESS 3200 5th Ave. **Suite** _____
PARCEL # _____

CONTACT		LICENSED CONTRACTOR Lic No. # _____	
Name <u>Doug Hawkins</u>	Street Address <u>203 B Kenroy Lane</u>	Name <u>GPS Specialty Construction</u>	Address <u>203 B Kenroy Lane</u>
City/State/Zip <u>Roseville, CA</u>	Phone <u>786-3330</u> FAX _____	City/State/Zip <u>Roseville, CA</u>	Phone <u>786-3330</u> FAX _____
E-mail: _____		E-mail: _____	
ARCHITECT/ENGINEER		OWNER	
Name <u>Eric Reitzell Engineering</u>	Address <u>5029 Burnbrae Place</u>	Name <u>McGeorge / UDP</u>	Address <u>3200 5th Ave</u>
City/State/Zip <u>Antelope, CA</u>	Phone _____ FAX _____	City/State/Zip <u>Sacramento, CA</u>	Phone _____ FAX _____
E-mail: _____		E-mail: _____	

→ Will permittee have any employees on the jobsite? No Yes → **INSURANCE CO:** State Comp
 → **WORKER'S COMPENSATION POLICY #** 69222-84 **EXPIRATION DATE:** 10/31/03

NATURE OF WORK IN DETAIL: Install 8 flag poles

OCCUPANT/TENANT: McGeorge **VALUATION:** \$ 10,000.00

FLOOD STATUS						S.C.A.T.								
JOB DESCRIPTION						<input type="checkbox"/> BLDG <input type="checkbox"/> SHELL <input type="checkbox"/> APT <input type="checkbox"/> TI () <input type="checkbox"/> REM () <input type="checkbox"/> SW <input type="checkbox"/> FIRE <input type="checkbox"/> ADD <input type="checkbox"/> OTHER <input type="checkbox"/>								
INSPECTION DISCIPLINES						BLDG		MECH		PLUMB		ELEC	SITE	FIRE
# Stories	1" flr Area.	Total Area	Use Zone	Occp Group	Const type	Fire Req. Y / N		Fed Code		Vio. File				
						SPR	ALARM					PW	UTIL	
B	L	P	M	E	F	S		D						

COMMENTS:

REGIONAL SANITATION FEES? Yes No **HEALTH DEPARTMENT?** Yes No
WATER FLOW TEST FOR NEW BUILDINGS OR ADDITIONS? Yes No

City of Sacramento Planning Division
PLANNING REVIEW FOR BUILDING PERMIT SUBMITTAL

ADDRESS: 3200 5 TH AVENUE	APN: 013-0136-015
DRPB AREA / PUD / SPD: OAK PARK DR	ZONING: R-1
EXISTING LAND USE: MC GEORGE SCHOOL OF LAW	
PROPOSED USE: 8 NEW FLAG POLES	
<p>PLANNING STAFF WILL CHECK ONE OR MORE OF THE ITEMS BELOW:</p> <p><input type="checkbox"/> Planning review is NOT required.</p> <p><input type="checkbox"/> Use is NOT allowed; applicant CANNOT submit for plan check.</p> <p><input type="checkbox"/> Requires APPLICATION(s): PC ZA IR ER DR PB</p> <p style="padding-left: 40px;">Required Planning application must be submitted <i>before</i> project can be submitted for plan check.</p> <p><input type="checkbox"/> Application(s) IN PROGRESS:</p> <p style="padding-left: 40px;">Applicant may submit for concurrent building permit plan check, at applicant's risk. Building Division must check with Planning staff and/or SITE before issuing building permit.</p> <p><input type="checkbox"/> Application(s) COMPLETED:</p> <p style="padding-left: 40px;">Building permit must conform to approved plans and comply with all conditions of approval. Do NOT issue building permit prior to end of 10 day appeal period.</p> <p><input type="checkbox"/> Plans may be submitted for plan check. Plan checker(s) shall confirm compliance with Zoning Ordinance requirements and all applicable development standards <i>prior to issuance</i> of building permit.</p> <p><input type="checkbox"/> Meets setback & lot coverage requirements as shown on site plan provided.</p> <p><input type="checkbox"/> Plans to be submitted have been stamped/signed by Planning counter staff.</p> <p><input type="checkbox"/> Route to SITE for plan check and inspection.</p> <p><input type="checkbox"/> Preliminary review ONLY; the information on this form must be reviewed again and confirmed at the time of building permit submittal.</p>	
<p>COMMENTS: FLAG POLES APPROVED BY DR (LUIS SANCHEZ) 9/10/03.</p> <p>POLES CAN NOT BE IN THE FRONT SETBACK - MAX HEIGHT 18'</p>	
DATE: 9/11/03	BY: LINDA HAY <i>L. Hay</i>

" " Indicates placement of Barriers

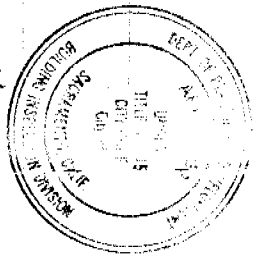
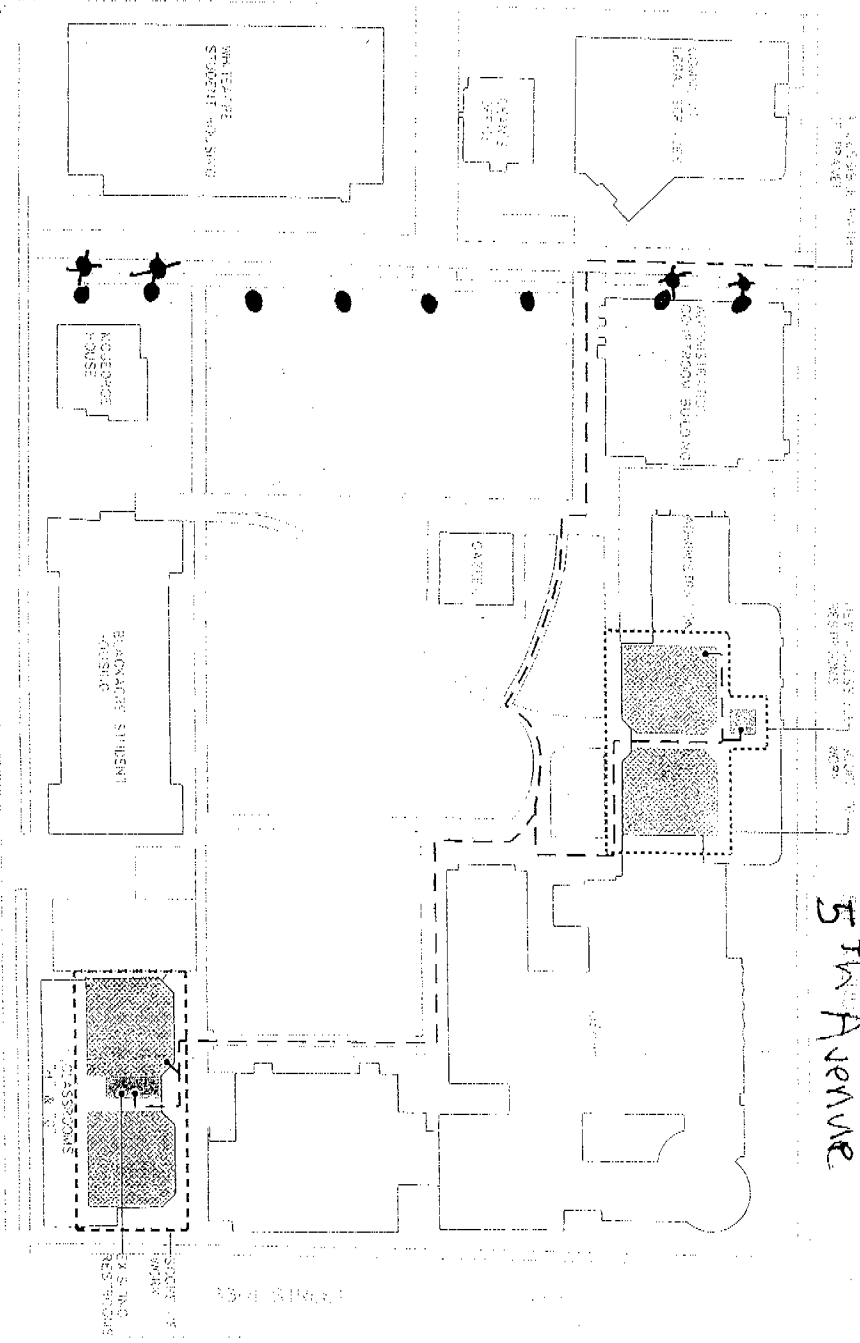

5th Avenue

The approval of this plan and specification SHALL NOT be held to permit or approve the violation of any City Ordinance or State Law.

UNIVERSITY OF THE SAN FRANCISCO DISTRICT
 1300 BAYVIEW AVENUE
 SACRAMENTO, CALIFORNIA 95834
 SAN FRANCISCO DISTRICT
 1300 BAYVIEW AVENUE
 SACRAMENTO, CALIFORNIA 95834

CONCRETE FOOTINGS DETAIL

CITY OF SACRAMENTO
 DESIGN REVIEW

PROJECT NO: NA

APPROVED BY: A. S. S. S.

APPROVAL DATE: 9/11/03

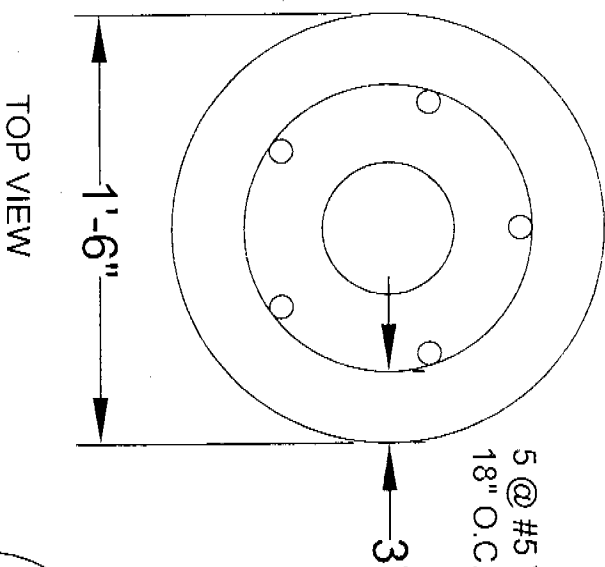

CONCRETE FOOTING

REBAR CAGE

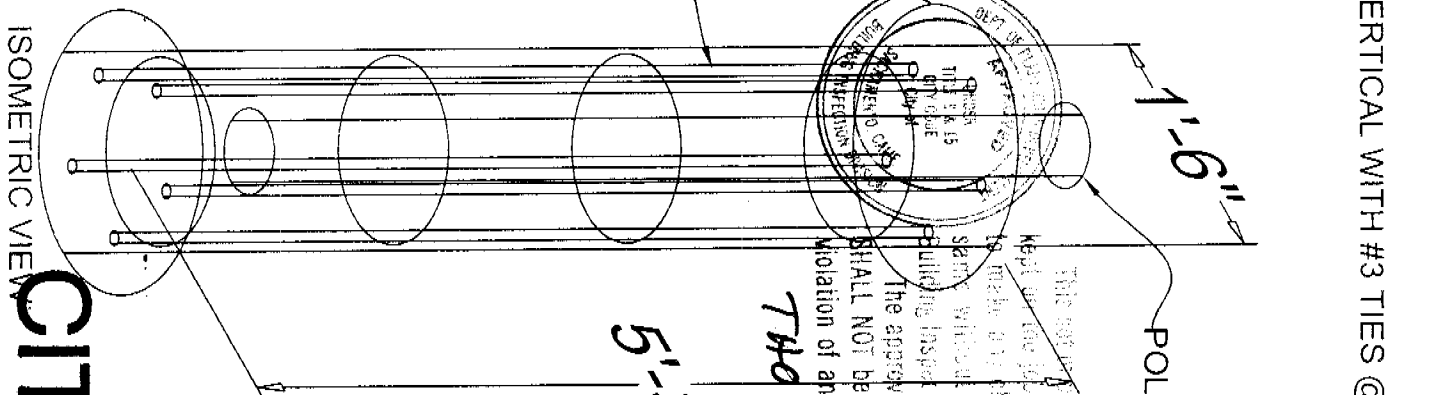

ISOMETRIC VIEW

5 @ #5 VERTICAL WITH #3 TIES @ 18" O.C.

POLE

5'-3"

THO 9/11/03

The approval of this plan and specification shall NOT be held to permit or approve the violation of any City Ordinance or State Law.

BANNER FABRICATION BY SIERRA DISPLAY.

THIS DRAWING IS THE PROPERTY OF GPS SPECIALTY CONSTRUCTION INC. IT IS TO BE USED ONLY FOR THE PROJECT AND SITE SPECIFICALLY IDENTIFIED HEREON. IT IS NOT TO BE REPRODUCED OR COPIED IN ANY MANNER WITHOUT THE WRITTEN PERMISSION OF GPS SPECIALTY CONSTRUCTION INC.

POLE 5 1/2" DIA.

6" DIA.

5" DIA.

3" DIA.

1 1/2"

4"

15'-0"

3'-0"

6'-0"

- SPECIFICATIONS
- 5" SCH. 40 PIPE
 - POWDERCOATED FINISH
 - 60% GLOSS BLACK
- CONCRETE FOOTING:
- 5'-3" DEEP
 - 18" DIAMETER
 - 3" MINIMUM BETWEEN

TOTAL OF 8 BANNERS & POLES

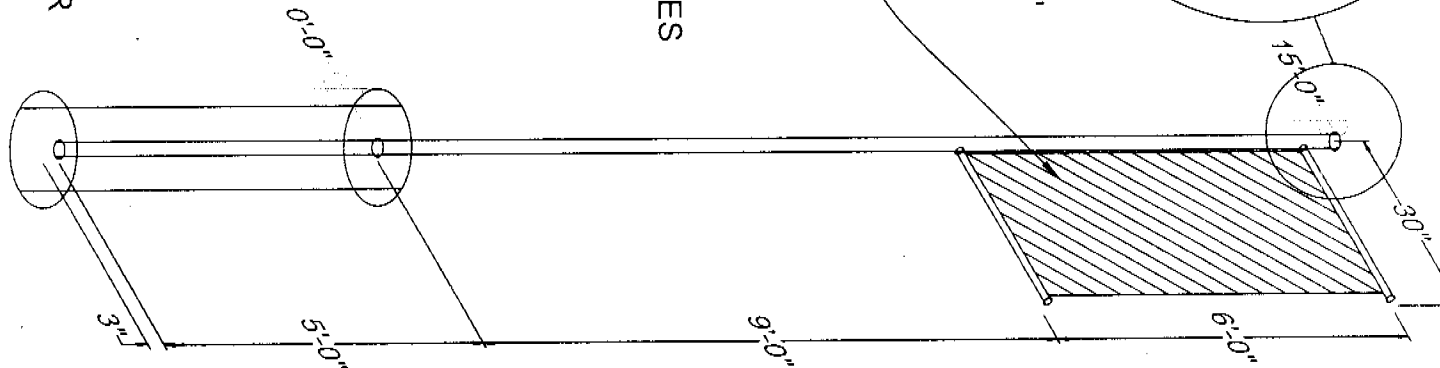

DATE: 08/15/03

SCALE: NOTED

JOB: NOTED

DRAWN: M.K.

SHEET: 1

OF 1 SHEETS

McGEORGE SCHOOL OF LAW

3200 FIFTH AVE. SACRAMENTO, CA 95817

GPS SPECIALTY CONSTRUCTION INC.

203 B KENROY LANE ROSEVILLE, CA 95678

TELEPHONE: 916-786-3330 FAX: 916-786-0504

CONTRACTOR LICENSE# 731185 B & D - 03

REVISIONS	DATE	BY

GPS SPECIALTY CONSTRUCTION INC. does not represent that these plans or the specifications in connection therewith are suitable, whether or not modified for any other site than the one they were prepared. GPS SPECIALTY CONSTRUCTION INC. disclaims responsibility for these plans and specification if they were used in whole or in part at any other site. All drawings and written material appearing herein constitute the original and unpublished work of GPS SPECIALTY CONSTRUCTION INC. and the same may not be duplicated, used, or disclosed with out written consent of GPS SPECIALTY CONSTRUCTION INC.

CITY COPY