

11



CITY OF SACRAMENTO

CITY MANAGER'S OFFICE
RECEIVED
AUG 11 1982

DEPARTMENT OF ENGINEERING
915 I STREET
CITY HALL ROOM 207
SACRAMENTO, CALIFORNIA 95814
TELEPHONE (916) 449-5261

J.F. VAROZZA
CITY ENGINEER
M.H. JOHNSON
ASSISTANT CITY ENGINEER

August 9, 1982

APPROVED
BY THE CITY COUNCIL

AUG 17 1982

OFFICE OF THE
CITY CLERK

City Council
Sacramento, California

Honorable Members in Session:

SUBJECT: Revocable Encroachment Permit - Forum Building Associates LTD

SUMMARY:

Forum Building Associates LTD has applied for a revocable encroachment permit for the purpose of constructing a sidewalk grate. The City Engineer recommends that the permit be granted.

BACKGROUND:

The area for which this request is being made consists of an area adjacent to permittee's property 3' x 3', 150' south of the south side of K Street and 10' west of the east side of 9th Street at 1107 9th Street (County Assessor's Parcel No. 6-102-1).

RECOMMENDATION:

The City Engineer recommends that the attached resolution be passed granting a revocable encroachment permit to Forum Building Associates LTD in the area and for the purpose outlined above.

Respectfully submitted,

J. F. Varozza
J. F. VAROZZA
City Engineer

Recommendation Approved:

Walter J. Slipes, Jr.
Walter J. Slipes, City Manager

14-R-030-00-0

cc: Glenn Marshall
Tim Sullivan
Jim Bloodgood
Bill Seeber

August 17, 1982
District #1

CONFIDENTIAL

NOV 19 1954

MEMPHIS

TO : SAC, MEMPHIS (44-1987) FROM : SAC, JACKSON (44-1987)

RE : MURKIN; JACKSON TELETYPE TO BUREAU, 10/28/54

FOR INFORMATION OF THE JACKSON OFFICE, THE FOLLOWING IS A SUMMARY OF THE

RESULTS OF THE INVESTIGATION CONDUCTED AT JACKSON, MISSISSIPPI, ON 10/28/54:

1. THE JACKSON OFFICE HAS BEEN ADVISED THAT THE SUBJECT, [REDACTED],

IS CURRENTLY EMPLOYED AS A [REDACTED] AT THE [REDACTED] OFFICE,

JACKSON, MISSISSIPPI. THE SUBJECT'S EMPLOYMENT RECORDS AT THIS OFFICE

REVEAL THAT HE HAS BEEN EMPLOYED SINCE [REDACTED] 1954.

2. THE JACKSON OFFICE HAS BEEN ADVISED THAT THE SUBJECT IS A [REDACTED]

AND IS CURRENTLY [REDACTED] AT THE [REDACTED] OFFICE,

JACKSON, MISSISSIPPI. THE SUBJECT'S EMPLOYMENT RECORDS AT THIS OFFICE

REVEAL THAT HE HAS BEEN EMPLOYED SINCE [REDACTED] 1954.

3. THE JACKSON OFFICE HAS BEEN ADVISED THAT THE SUBJECT IS A [REDACTED]

AND IS CURRENTLY [REDACTED] AT THE [REDACTED] OFFICE,

JACKSON, MISSISSIPPI. THE SUBJECT'S EMPLOYMENT RECORDS AT THIS OFFICE

REVEAL THAT HE HAS BEEN EMPLOYED SINCE [REDACTED] 1954.

4. THE JACKSON OFFICE HAS BEEN ADVISED THAT THE SUBJECT IS A [REDACTED]

AND IS CURRENTLY [REDACTED] AT THE [REDACTED] OFFICE,

JACKSON, MISSISSIPPI. THE SUBJECT'S EMPLOYMENT RECORDS AT THIS OFFICE

REVEAL THAT HE HAS BEEN EMPLOYED SINCE [REDACTED] 1954.

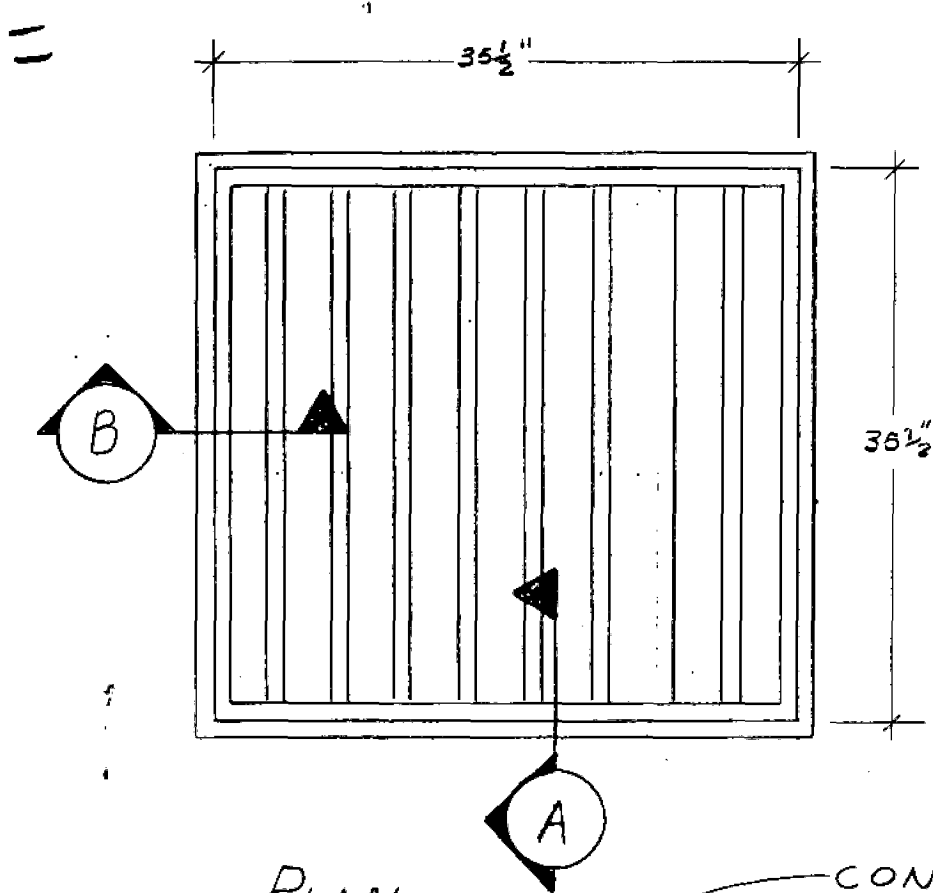

PLAN
1" = 1'-0"

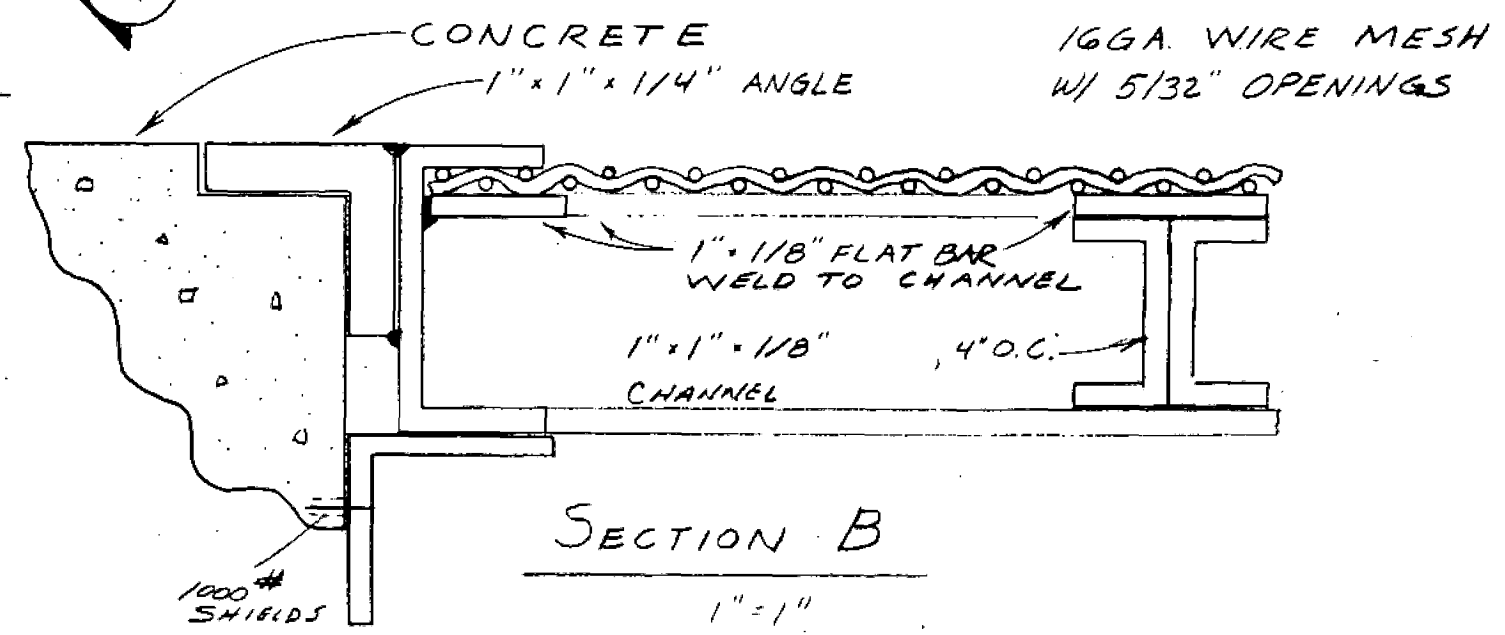
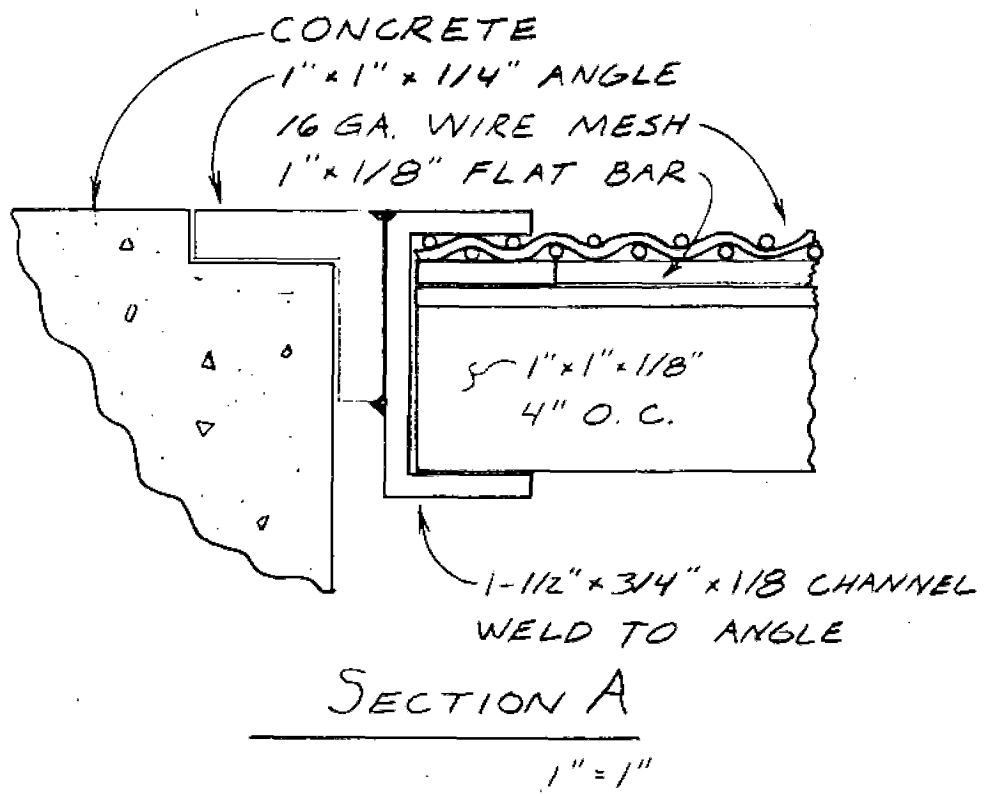

GRATE
DETAILS -
FORUM
BUILDING -
AIRCO
MECHANICAL

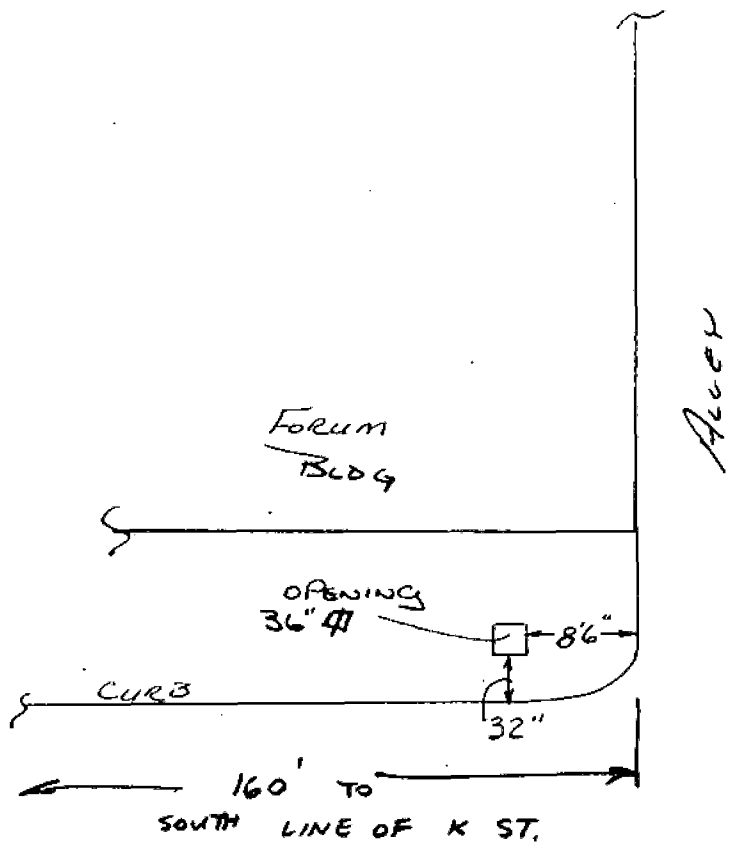

LOCATION OF GRATE
AIRC0 MECHANICAL

11

RESOLUTION No. 82-570

Adopted by The Sacramento City Council on date of

August 17, 1982

RESOLUTION GRANTING REVOCABLE ENCROACHMENT TO:

Forum Building Associates, LTD

BE IT RESOLVED BY THE COUNCIL OF THE CITY OF SACRAMENTO:

That a revocable encroachment permit for the purpose of
constructing a sidewalk grate

is hereby granted to Forum Building Associates, LTD, whose
address is as follows: 601 University Avenue, Suite 135, Sacto 95825.

The encroachment area is described as follows:

An area adjacent to permittee's property. An area 3' x 3', 150' south of the south side of K Street and 10' west of the east side of 9th Street at 1107 9th Street (County Assessor's Parcel Number 6-102-1).

This permit is granted subject to the "General Provisions - Revocable Encroachment Permit", which were adopted by the City Council in Resolution No. 81-845 dated November 17, 1981, and the hereinafter specified special conditions, if any. This permit shall be effective only after the applicant files with the Risk Management & Insurance Division of the City of Sacramento, the insurance certificates required by the General Provisions.

APPROVED
BY THE CITY COUNCIL

AUG 17 1982

OFFICE OF THE
CITY CLERK

RECEIVED
MAY 11 1950
U.S. AIR FORCE

SPECIAL CONDITIONS

1. Permittee shall comply with the requirements of the City Building Inspection Department.
2. Permittee shall contact the City sidewalk Inspector at 449-5236 prior to construction.

MAYOR

ATTEST:

CITY CLERK

APPROVED
BY THE CITY COUNCIL

AUG 17 1992

OFFICE OF THE
CITY CLERK

1941
1942
1943
1944
1945
1946
1947
1948
1949
1950
1951
1952
1953
1954
1955
1956
1957
1958
1959
1960
1961
1962
1963
1964
1965
1966
1967
1968
1969
1970
1971
1972
1973
1974
1975
1976
1977
1978
1979
1980
1981
1982
1983
1984
1985
1986
1987
1988
1989
1990
1991
1992
1993
1994
1995
1996
1997
1998
1999
2000
2001
2002
2003
2004
2005
2006
2007
2008
2009
2010
2011
2012
2013
2014
2015
2016
2017
2018
2019
2020
2021
2022
2023
2024
2025