

CITY OF SACRAMENTO
1231 I Street, Sacramento, CA 95814

Permit No: 0014075
Insp Area: 1

Site Address: 1420 29TH ST SAC
Parcel No: 007-0273-023

Sub-Type: COM
Housing (Y/N): N

CONTRACTOR
SENTINEL FIRE EQUIPMENT
5702 BROADWAY
SAC CA 95820

OWNER
KNUDSON JAMES R/MARGARET E/T
1420 29TH ST
SACRAMENTO CA 95816

ARCHITECT

Nature of Work: EXHAUST HOOD FIRE SUPPRESSION SYSTEM

CONSTRUCTION LENDING AGENCY: I hereby affirm under penalty of perjury that there is a construction lending agency for the performance of the work for which this permit is issued (Sec. 3097, Civ. C).

Lender's Name _____ Lender's Address _____

LICENSED CONTRACTORS DECLARATION: I hereby affirm under penalty of perjury that I am licensed under provisions of Chapter 9 (commencing with section 7000) of Division 3 of the Business and Professions Code and my license is in full force and effect.

License Class C16 License Number 369187 Date 12-5-2000 Contractor Signature SENTINEL FIRE EQUIPMENT

OWNER-BUILDER DECLARATION: I hereby affirm under penalty of perjury that I am exempt from the contractors License Law for the following reason (Sec. 7031.5, Business and Professions Code: any city or county which requires a permit to construct, alter, improve, demolish, or repair any structure, prior to its issuance, also requires the applicant for such permit to file a signed statement that he or she is licensed pursuant to the provisions of the Contractors License Law (Chapter 9 (commencing with Section 7000) of Division 8 of the Business and Professions Code) or that he or she is exempt therefrom and the basis for the alleged exemption. Any violation of Section 7031.5 by any applicant for a permit subjects the applicant to a civil penalty of not more than five hundred dollars (\$500.00);

____ I, as a owner of the property, or my employees with wages as their sole compensation, will do the work, and the structure is not intended or offered for sale (Sec. 7044, Business and Professional Code: The Contractors License Law does not apply to an owner of property who builds or improves thereon, and who does such work himself or herself or through his/her own employees, provided that such improvements are not intended or offered for sale. If, however, the building or improvement is sold within one year of completion, the owner-builder will have the burden of proving that he/she did not build or improve for the purpose of sale.)

____ I, as owner of the property, am exclusively contracting with licensed contractors to construct the project (Sec. 7044, Business and Professions Code: The Contractors License Law does not apply to an owner of property who builds or improves thereon, and who contracts for such projects with a contractor(s) licensed pursuant to the Contractors License Law).

____ I am exempt under Sec. _____ B & PC for this reason: _____

Date _____ Owner Signature _____

IN ISSUING THIS BUILDING PERMIT, the applicant represents, and the city relies on the representation of the applicant, that the applicant verified all measurements and locations shown on the application or accompanying drawings and that the improvement to be constructed does not violate any law or private agreement relating to permissible or prohibited locations for such improvements. This building permit does not authorize any illegal location of any improvement or the violation of any private agreement relating to location of improvements.

I certify that I have read this application and state that all information is correct. I agree to comply with all city and county ordinances and state laws relating to building construction and hereby authorize representative(s) of this city to enter upon the abovementioned property for inspection purposes.

Date 12-5-2000 Applicant/Agent Signature Wayne Farrington

WORKER'S COMPENSATION DECLARATION: I hereby affirm under penalty of perjury one of the following declarations:

____ I have and will maintain a certificate of consent to self-insure for workers' compensation as provided for by Section 3700 of the Labor Code, for the performance of work for which the permit is issued.

____ I have and will maintain workers' compensation insurance, as required by Section 3700 of the Labor Code, for the performance of the work for which this permit is issued. My workers' compensation insurance carrier and policy number are:

Carrier STATE FUND Policy Number 565-00-009600 Exp Date 10/01/2001

(This section need not be completed if the permit is for \$100 or less) I certify that in the performance of the work for which this permit is issued, I shall not employ any person in any manner so as to become subject to the workers' compensation laws of California and agree that if I should become subject to the workers' compensation provisions of Section 3700 of the Labor Code, I shall forthwith comply with those provisions.

Date 12-5-2000 Applicant Signature Wayne Farrington

WARNING: FAILURE TO SECURE WORKER'S COMPENSATION COVERAGE IS UNLAWFUL AND SHALL SUBJECT AN EMPLOYER TO CRIMINAL PENALTIES AND CIVIL FINES UP TO ONE HUNDRED THOUSAND DOLLARS (\$100,000) IN ADDITION TO THE COST OF COMPENSATION, DAMAGES AS PROVIDED FOR IN SECTION 3706 OF THE LABOR CODE, INTEREST AND ATTORNEY'S FEE.

THIS PERMIT SHALL EXPIRE BY LIMITATION IF WORK IS NOT COMMENCED WITHIN 180 DAYS.

APPLICATION FOR COMMERCIAL BUILDING PERMIT

CITY OF SACRAMENTO
DEVELOPMENT SERVICES DIVISION
PERMIT SERVICES SECTION

1231 I Street, Rm. 200
 Sacramento, CA 95814 (916) 264-7619 FAX 264-7046

ACTIVITY # 0014075	Insp. Area 1C
--	---

Applicant **MUST** complete ALL Unshaded areas

ADDRESS 1420 29th STREET Suite _____
 PARCEL # 007 0273 023

<p style="text-align: center;">CONTACT</p> <p>Name <u>Limbo Y TACO</u> Street Address <u>1420 29th STREET</u> City/State/Zip <u>SACRAMENTO, CA - 95816</u> Phone _____ FAX _____ E-mail: _____</p>	<p style="text-align: center;">LICENSED CONTRACTOR Lic No. # <u>369137-16</u></p> <p>Name <u>SENTINEL FIRE EQUIP. CO</u> Address <u>5702 BROADWAY</u> City/State/Zip <u>SACRAMENTO CA 95820</u> Phone <u>916 455-5535</u> FAX <u>455-4104</u> E-mail: <u>455-5630</u></p>
<p style="text-align: center;">ARCHITECT/ENGINEER</p> <p>Name _____ Address _____ City/State/Zip _____ Phone _____ FAX _____ E-mail: _____</p>	<p style="text-align: center;">OWNER</p> <p>Name _____ Address _____ City/State/Zip _____ Phone _____ FAX _____ E-mail: _____</p>

→ Will permittee have any employees on the jobsite? No Yes → INSURANCE CO: STATE COMPENSATION INS. FUND
 → WORKER'S COMPENSATION POLICY # 585009600 EXPIRATION DATE: 10-01-01

NATURE OF WORK IN DETAIL: _____
EXHAUST HOOD FIRE SYSTEMS

OCCUPANT/TENANT: _____ VALUATION: \$ 3500.00

FLOOD STATUS:				S.C.A.T.						
JOB DESCRIPTION		BLDG	SHELL	APT	TI()	REM()	SW	FIRE	ADD	OTH
INSPECTION DISCIPLINES		BLDG	MECH	PLUMB	ELEC	SITE	FIRE			
# Stories	1st fir Area	Total Area	Use Zone	Occp Group	Const type	Fire Req. Y / N		Fed Code	Vio. File	
				<u>A</u>		SPR	ALARM	<u>18</u>	[H]	[Quad]
<u>B</u>	<u>L</u>	<u>P</u>	<u>M</u>	<u>E</u>	F	<u>S</u>	<u>D</u>	<u>75</u>	PW	UTIL

COMMENTS: _____

REGIONAL SANITATION FEES? Yes No HEALTH DEPARTMENT? Yes No

WATER FLOW TEST FOR NEW BUILDINGS OR ADDITIONS? Provided Faxed

CITY OF SACRAMENTO
DEVELOPMENT SERVICES DIVISION

EXPRESS PLAN REVIEW

SUBMITTAL DATES					
1st Review		2nd Review		3rd Review	
IN	OUT	IN	OUT	IN	OUT
/ /	/ /	/ /	/ /	/ /	/ /

PLAN CHECK # 075
 ADDRESS: 1420 29th St
 Commercial Residential



ACCEPTED by (Staff):

DISCIPLINE	1ST REVIEW			2ND REVIEW			3RD REVIEW		
	Status	Staff	Date	Status	Staff	Date	Status	Staff	Date
DIS/SAFETY									
STRUCTURAL									
MECHANICAL/PLUMBING									
ELECTRICAL									
FIRE	13	BTF	11/29/00						
LANDSCAPING									

STAFF COMMENTS: _____

ST 0514075
45
11-29-00
1420 29th

This set of plans and specifications shall be kept on the job at all times and it is awarded to make any changes or alterations from the same without written approval from the Building Inspector Division. The approval of this plan and specification shall NOT be held to permit any violation of any City Ordinance or State Law.

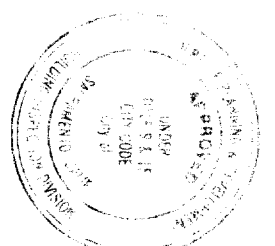

**RECEIVED
ISSUED**

DEC 8 5 2000

Sacramento Building Division

APPROVED
James R. Smith
Sacramento Fire Department
Division Chief

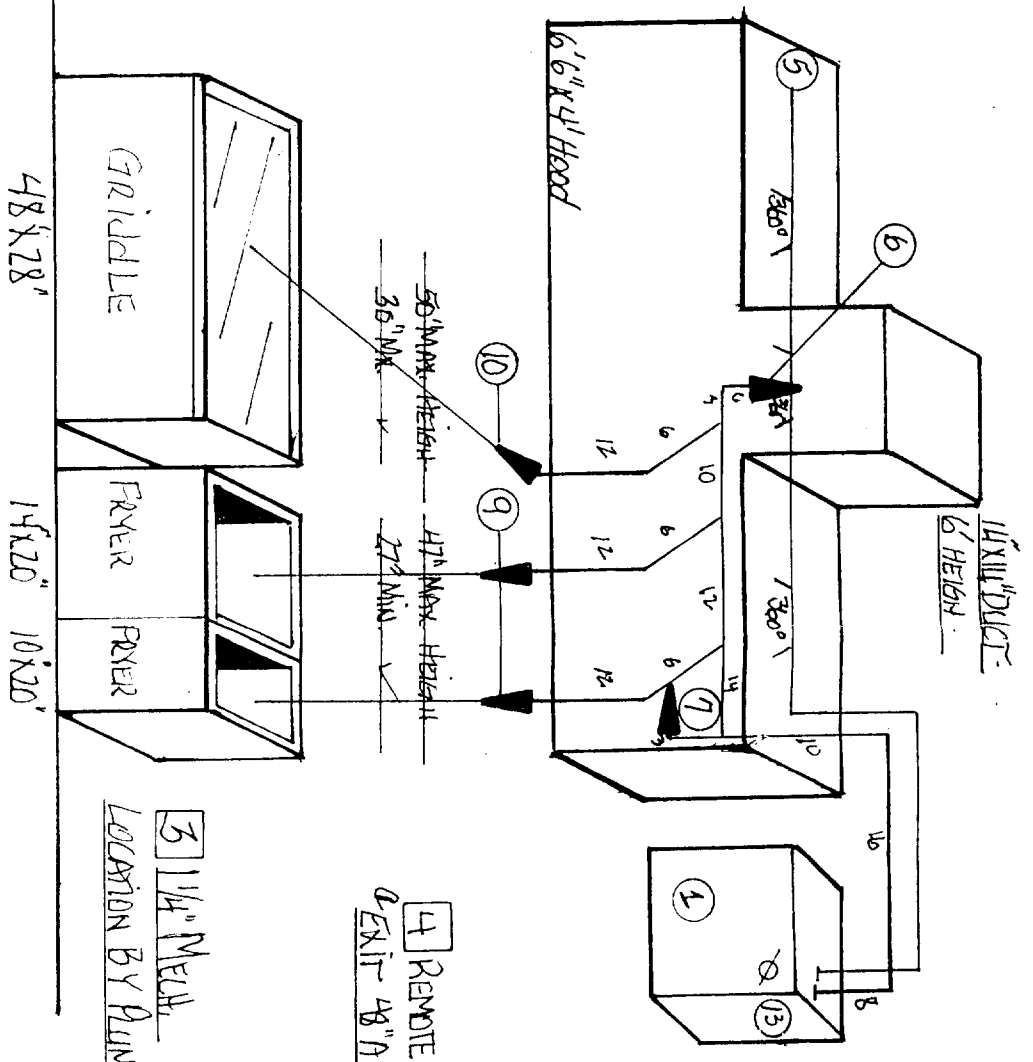

*ALL PIPING IS 3/8" BLK-SCHD. 40
 *AS BUILT PIPING DIMENSIONS TO BE FURNISHED AT FINAL TEST
 *TO BE INSTALLED AS-PER ANSUL MANUAL, NFPA 77A, AND LOCAL FIRE AUTH.
 *MAX. FLOW POINTS IS (11), BEING USED IS (9) FLOW POINTS
 SINGLE FILTER BANK

Established 1929
SENTINEL FIRE
 EQUIPMENT COMPANY
 C-16 LICENSE NO. 369137
 5702 ROADWAY, SACRAMENTO, CA 95820
 SALES AND SERVICE
 ANSUL AUTHORIZED DISTRIBUTOR
 RESTAURANT HOOD SYSTEMS
 VEHICLE FEE PROTECTION
 (916) 455-5630

BRAND: ANSUL
 MODEL: R102 711300 36AL
 DATE: 11-22-2000
 JOB NAME: Jimboy TKO #4
 ADDRESS: 1420 29th STREET
 CITY: SACRAMENTO, CA 95816
 DRAWN BY: *[Signature]*

NO.	DESCRIPTION	PART NO	NO.	DESCRIPTION	PART NO	NO.	DESCRIPTION	PART NO
1	ANSUL (R102) SYSTEM	79290	6	DUCT NOZZLE	ZW 419339	11	RADIANT EROLLER	
2	OTHER		7	PLENUM NOZZLE-8'	1M 419335	12	SALAMANDER NOZZLE	
3	GAS VALVE 1/4" MECH.	55604	8	PLENUM NOZZLE-4'		13	Switch For Alarm Bell-INTERLOCK	ZZ222
4	REMOTE PULL BOX	4835	9	FRYER NOZZLE	2RFRS 230	14		
5	DETECTOR BRACKET 360°	38837	10	'GRILL NOZZLE	2RFRS 260	15		

Office Copy

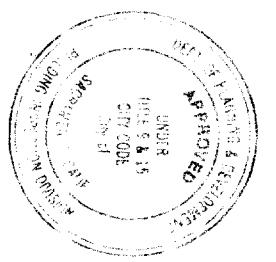

This set of plans and specifications must be kept on the job at all times and it is unlawful to make any changes or alterations without the same without written permission from the Building Inspection Division.
The approval of this plan and specification SHALL NOT be held to permit or approve the violation of any City Ordinance or State Law.

ISSUED

LFC 0 5 2000

Sacramento Building Division

38 J. J. J. 11-29-00

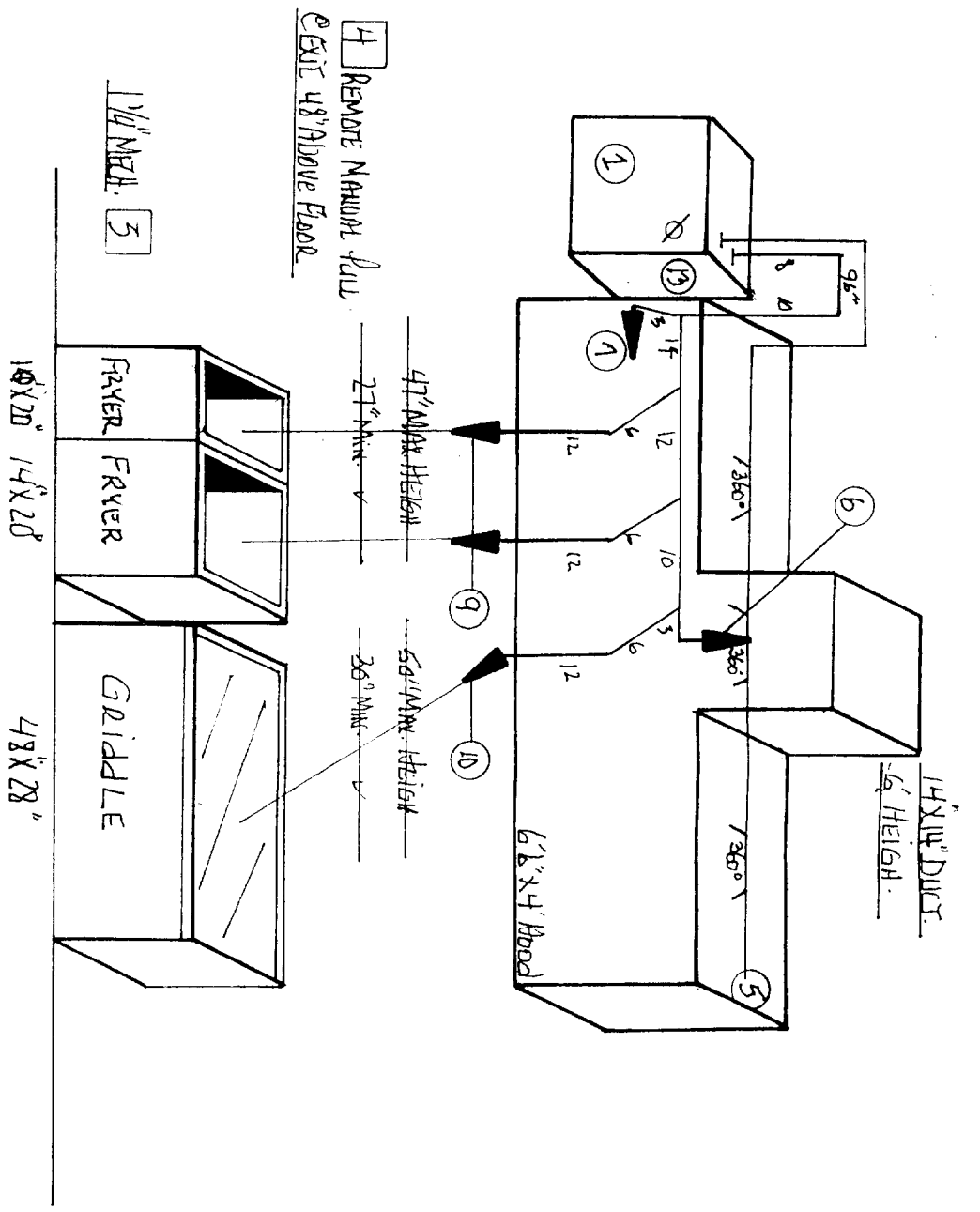

*ALL PIPING IS 3/8" ELK.-SCHD. 40
 *AS BUILT PIPING DIMENSIONS TO BE FURNISHED AT FINAL TEST
 *TO BE INSTALLED AS-PER ANSUL MANUAL, NFPA 77A, AND LOCAL FIRE AUTH.
 *MAX. FLOW POINTS IS (11), BEING USED IS (9) FLOW POINTS
 SINGLE FILTER BANK

SENTINEL FIRE
 EQUIPMENT COMPANY
 C-16 LICENSE NO. 369137
 5702 EROADWAY, SACRAMENTO, CA 95820 (916) 455-5650

SALES AND SERVICE
 ANSUL AUTHORIZED DISTRIBUTOR
 RESTAURANT HOOD SYSTEMS
 VEHICLE FIRE PROTECTION

BRAND: ANSUL
 MODEL: RID2 UL300 3GA
 DATE: 11-22-2000
 CITY: SACRAMENTO, CA 95816

JIMBOY TACO #74
 1420 29th STREET
 SACRAMENTO, CA 95816

NO.	DESCRIPTION	PART NO.	NO.	DESCRIPTION	PART NO.	NO.	DESCRIPTION	PART NO.
1	ANSUL (R102) SYSTEM	79290	6	DUCT NOZZLE	2W	11	RADIANT EROLLER	
2	OTHER		7	PLENUM NOZZLE-8'	1W	12	SALAMANDER NOZZLE	
3	GAS VALVE 1/4" NEH.	55604	8	PLENUM NOZZLE-4'		13	Switch for Alarm & Elec. Interlock	32222
4	REMOTE PULL BOX	4835	9	FRYER NOZZLE	2R. R.	14		
5	DETECTOR BRACKET 360°	5837	10	/GRILL NOZZLE 2R. R.	260	15		

Estimated 1929
 ANSUL AUTHORIZED DISTRIBUTOR
 RESTAURANT HOOD SYSTEMS
 VEHICLE FIRE PROTECTION
 (916) 455-5650

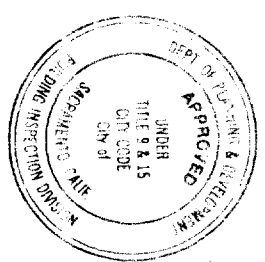
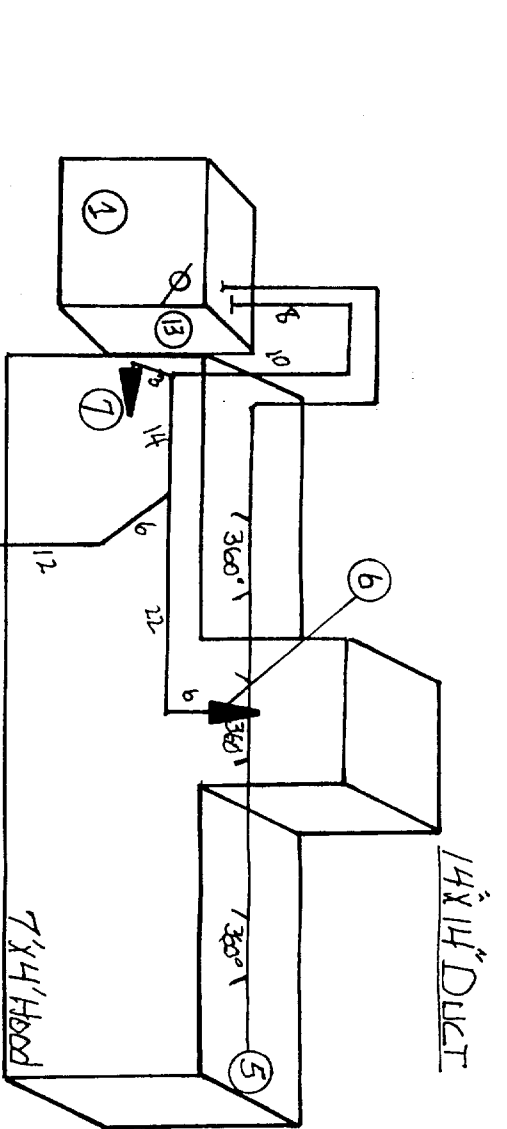

This set of plans and specifications must be kept on the job at all times and it is unlawful to make any changes or alterations from the same without written permission from the Building Inspection Division.
The approval of this plan and specification SHALL NOT be held to permit or approve the violation of any City Ordinance or State Law.

ISSUED

FEB 0 5 2000

Sacramento Building Division

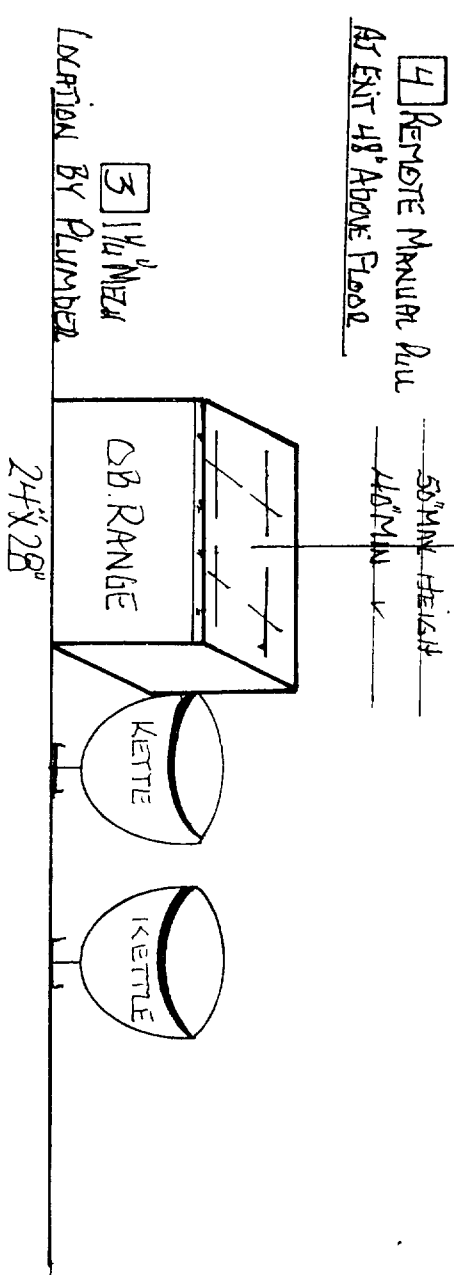

APPROVED
BA Foster 11-29-00
Sacramento Fire Department

*ALL PIPING IS 3/8" ELK.-SCHD. 40
 *AS BUILT PIPING DIMENSIONS TO BE FURNISHED AT FINAL TEST
 *TO BE INSTALLED AS-PER ANSUL MANUAL, NFPA 77A, AND LOCAL FIRE AUTH.
 *MAX. FLOW POINTS IS (//), BEING USED IS (S) FLOW POINTS
 Single Filter Bank

Established 1929
SENTINEL FIRE
 EQUIPMENT COMPANY
 C-16 LICENSE NO. 369137
 5702 HOWARD AVE., SACRAMENTO, CA 95820 (916) 455-5630

SALES AND SERVICE
 ANSUL AUTHORIZED DISTRIBUTOR
 RESTAURANT HOOD SYSTEMS
 VEHICLE FEE PROTECTION

BRAND: ANSUL
 MODEL: R102 TL300
 DATE: 11-22-2000

JOB NAME: Jimbo Taco #4
 ADDRESS: 1420 29th STREET
 CITY: SACRAMENTO, CA 95816

NO.	DESCRIPTION	PART NO	NO.	DESCRIPTION	PART NO	NO.	DESCRIPTION	PART NO
1	ANSUL (R102) SYSTEM	79290	6	DUCT NOZZLE	2W	11	RADIANT ROLLER	
2	OTHER		7	PLENUM NOZZLE-8'	1N	12	SALAMANDER NOZZLE	
3	GAS VALVE 1/4" MECH.	55604	8	PLENUM NOZZLE-4'		13	Switch For Alarm & Eject Intertec	32222
4	REMOTE PULL BOX	4835	9	FRYER NOZZLE		14		
5	DETECTOR BRACKET 360	56837	10	RANGE / NOZZLE 24x28	245	15		

SCALE: 1/8"

DRAWN BY: [Signature]

This set of plans and specifications must be kept on the job at all times and it is unlawful to make any changes or alterations from the same without written permission from the Building Inspection Division.

The approval of this plan and specification SHALL NOT be held to permit or approve the violation of any City Ordinance or State Law.

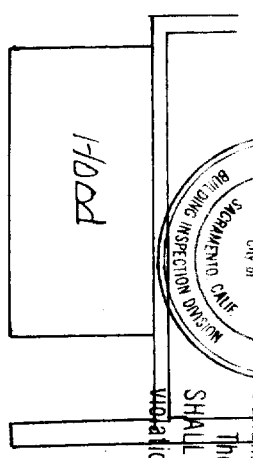
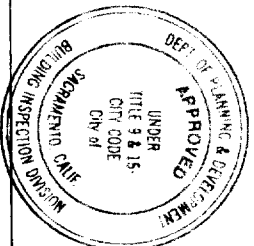

FRONT KITCHEN

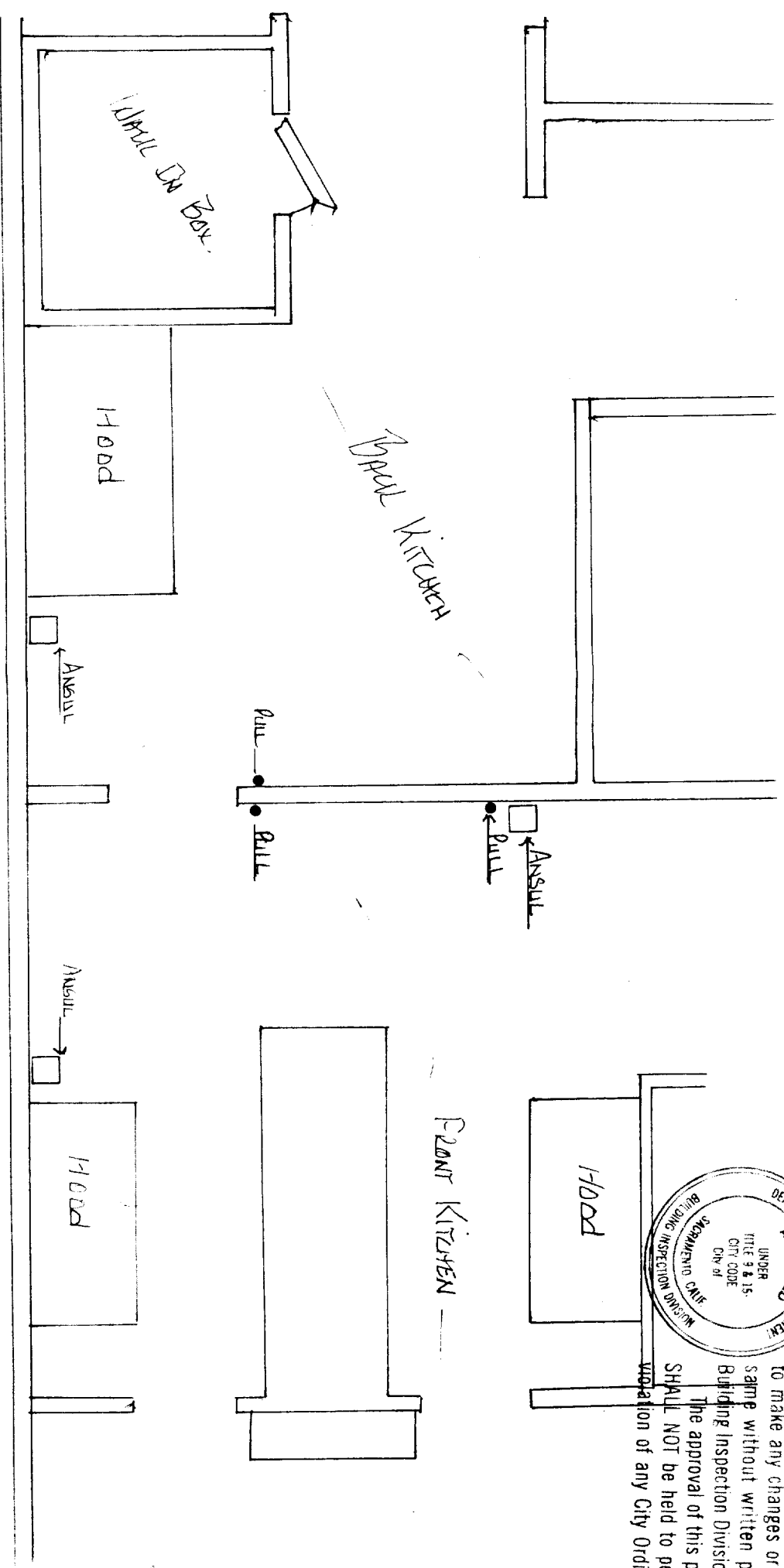
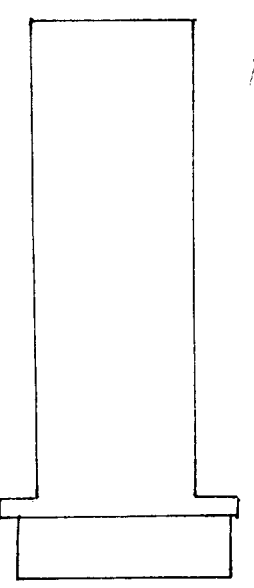

ISSUED

1000 A 5 2000

Sacramento Building Division

001407
ANSUL

DESIGN
INSTALLATION
RECHARGE AND
MAINTENANCE
MANUAL

Office Copy

R-102 RESTAURANT
FIRE SUPPRESSION
SYSTEM
(Standard UL 300 Listed)

CITY OF SACRAMENTO
PERMIT ADMINISTRATION

NOV 29 2000

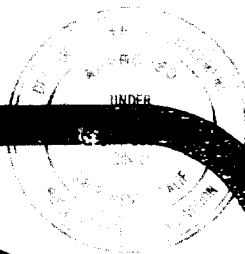

This set of plans
kept on the job at a
to make any chang
same without writ
Building inspection
The approval of
ALL work to be held
ation of any Cit

ications must be
nd it is unallow
ations from the
ission from the
Special Admin
for approval the
ce Law.

RECEIVED

ISSUED

NOV 05 2000

Sacramento Building Division

APPROVED

B. J. Foster 11-29-00

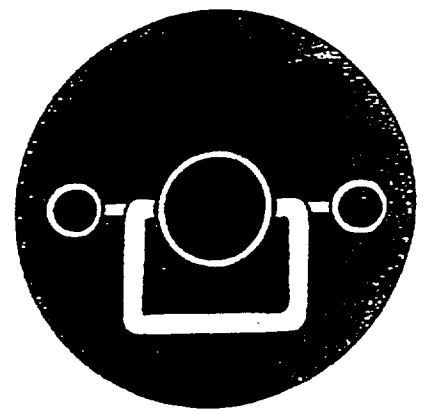

EXTINGUISHING AGENT

ANSULEX Low pH Liquid Fire Suppressant (1.5 gallon - Part No. 79694 or 3.0 gallon - Part No. 79372) is a potassium-based solution designed for fast knock-down and suppression of grease-related fires. The agent is shipped in plastic containers which provide one complete tank charge. Agent storage life expectancy is twelve years. The distributor must record the batch numbers and date of shipment receipt to be filed with each installation record.

ANSULEX™ LOW pH LIQUID FIRE SUPPRESSANT

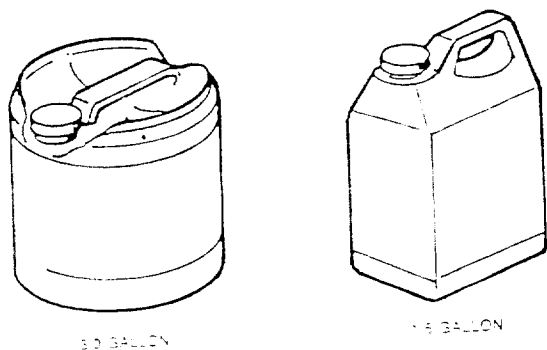

FIGURE 1

REGULATED RELEASE ASSEMBLY (MECHANICAL)

The ANSUL AUTOMAN Regulated Mechanical Release Assembly (3.0 gallon - Part No. 79290 or 1.5 gallon - Part No. 79291) contains the regulated release mechanism, agent tank, expellant gas hose for agent tank hookup, and enclosure knockouts to facilitate installing actuation piping; expellant piping; detection system; and additional equipment. This regulated release assembly is used in single, double, and multiple-tank systems and must be mounted to a rigid surface. The release mechanism can be used to interconnect both the actuation and expellant gas lines as required per system design. The regulator is designed to allow a constant flow of gas into the tank at 100 psi (690 kPa) when the system is actuated.

In single, double, and multiple-tank systems, the provided expellant gas hose connects the agent tank to the bottom outlet of the regulator. In double and multiple-tank system configurations, the back outlet of the regulator is used as an expellant gas feed for one additional tank-enclosure or tank-bracket hookup. The enclosure contains the required knockouts to facilitate this connection. If a pressure switch is to be attached to the regulator, additional fittings are required.

The tank is mounted within the enclosure. The tank contains an adaptor/tube assembly with a burst disc union. The burst disc helps prevent siphoning of the agent up the pipe due to significant temperature fluctuations in the area where the tank is located. The tank is mild steel and, under normal conditions, requires hydrostatic testing every twelve years.

The agent tank is shipped uncharged and must be filled with 1.53 gallons (5.8 L) or 3.06 gallons (11.6 L) of only ANSULEX Low pH Liquid Fire Suppressant during installation.

The detection and additional equipment required per system design are connected to the release mechanism. The enclosure contains knockouts to facilitate detection and additional hookups.

The system can be actuated automatically or manually. Automatic actuation occurs when a fusible link within the detection system separates in a fire condition. Manual actuation of the system occurs when personnel pull on the remote manual pull station pull ring.

"ANSUL AUTOMAN" REGULATED RELEASE ASSEMBLY (MECHANICAL)

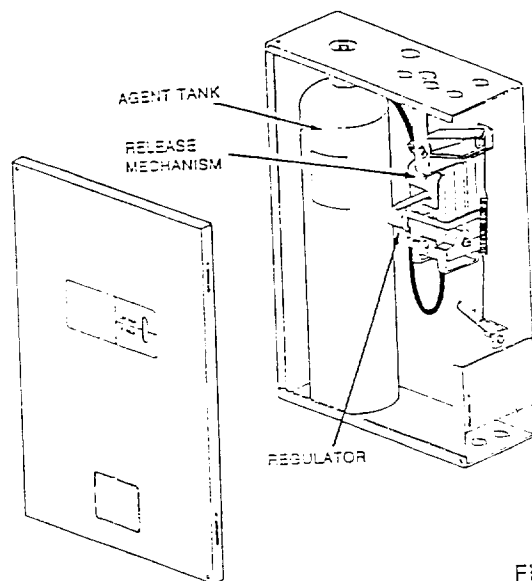

FIGURE 2

REGULATED RELEASE ASSEMBLY (ELECTRICAL)

The ANSUL AUTOMAN Regulated Electrical Release Assembly (3.0 gallon Part No. 79292) is identical to the mechanical version except it contains a factory installed 120 VAC solenoid and electrical switch.

The solenoid is used to provide electrical actuation of the release mechanism. The electric switch is used to protect the solenoid by opening the circuit to the solenoid once the system is fired. Additional electrical switches can be added as required for automatic equipment and gas shut-off accessories, as well as initiating audible and visual alarms.

"ANSUL AUTOMAN" REGULATED RELEASE ASSEMBLY (ELECTRICAL)

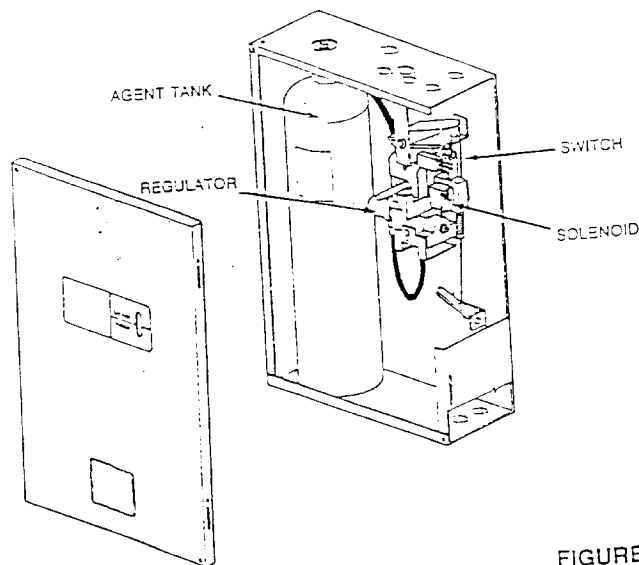

FIGURE 3

INSTALLATION INSTRUCTIONS

Before attempting any installation, the entire system design must have been determined including: Nozzle Placement, Tank Quantity, Actuation and Expellant Gas Piping, Distribution Piping, and Detection System Requirements and an installation sketch should be completed.

MOUNTING THE COMPONENTS

For successful system performance, the regulated release assembly, regulated actuator assembly(ies), and tank-enclosure(s) or tank-bracket assembly(ies) used must be located in areas where the air temperature will not fall below 32 °F (0 °C) or exceed 130 °F (54 °C). Also, the components must be arranged to conform to the actuation and expellant gas line, and the distribution piping guidelines noted in "System Design."

1.

CAUTION

Use only an ANSUL AUTOMAN Regulated Release assembly (Part No. 79290 – 3.0 gallon mechanical or 79292 – 3.0 gallon electrical or 79291 – 1.5 gallon mechanical or 79493 – OEM Release/Bracket Assembly). The regulator in this assembly is specifically designed to allow a regulated flow of expellant gas into the agent tank(s). Absence of this regulator could cause the tank(s) to rupture or create an improper system discharge.

Mount the regulated release assembly, OEM Release Assembly, and each regulated actuator assembly required by completing the following steps: See Figures 1, 2, and 3.

- a. Select a rigid surface for mounting the enclosure. The mounting locations must allow the regulated release assembly and the regulated actuator assembly(ies) to be within the limitation of the actuation and expellant gas line lengths and must be able to support the weight of the assembly(ies).
- b. Detach cover from the enclosure. Remove agent tank from enclosure and the expellant gas line hose from the tank/adaptor assembly.
- c. Secure enclosure box to selected mounting location using the four mounting holes. Use appropriate type of fasteners depending on the mounting surface.
- d. ¼"x3" molly bolts are used through plywood backing.

REGULATED RELEASE ASSEMBLY

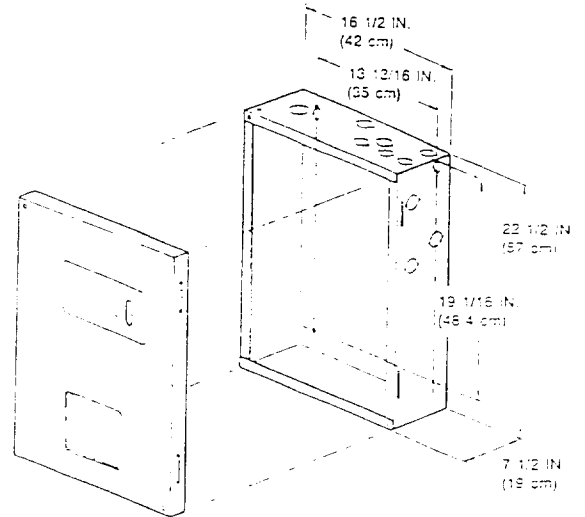

FIGURE 1

REGULATED ACTUATOR ASSEMBLY

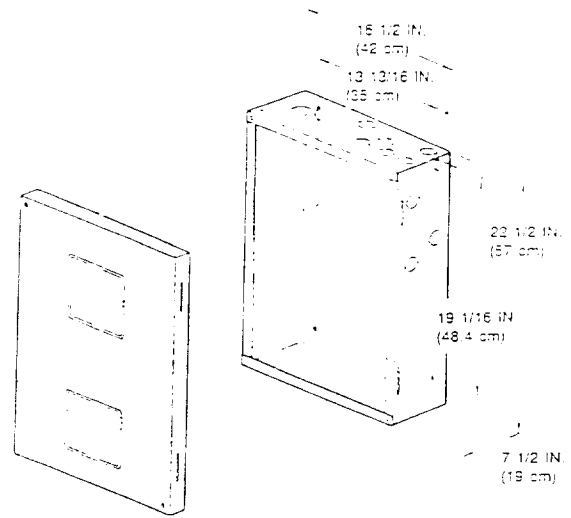

FIGURE 2

OEM RELEASE/BACKET ASSEMBLY

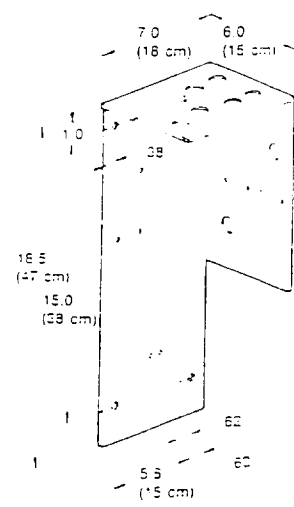

FIGURE 3

DESIGN AND APPLICATION

The Ansul R-102 Restaurant Fire Suppression System is designed to provide fire protection for restaurant cooking appliances, hoods, and ducts. It is a pre-engineered group of mechanical and electrical components for installation by an authorized Ansul distributor. The basic system consists of an ANSUL AUTOMAN regulated release assembly which includes a regulated release mechanism and a liquid agent storage tank housed within a single enclosure. Nozzles, detectors, cartridges, liquid agent, fusible links, pulley tees, and pulley elbows are supplied in separate packages in the quantities needed for each fire suppression system arrangement.

The system provides automatic actuation; or it can be actuated manually through a remote manual pull station. The gas or electrical supply to all protected appliances will be immediately shut off upon actuation of the system, using appropriate gas shut-off or electrical shut-down devices.

Additional equipment includes: remote manual pull station, mechanical and electrical gas valves, pressure switches, and electrical switches for automatic equipment and gas line shut-off. Accessories can be added, such as alarms, warning lights, etc., to installations where required.

The R-102 system suppresses fire by spraying the plenum area, the filters, cooking surfaces, and the exhaust duct system with a predetermined flow rate of ANSULEX Low pH Liquid Fire Suppressant. When the liquid agent is discharged onto a cooking appliance fire, it cools the grease surface, and reacts with the hot grease (saponification) forming a layer of soap-like foam on the surface of the fat. This layer acts as insulation between the hot grease and the atmosphere, thus helping to prevent the escape of combustible vapors.

Exhaust fans in the ventilating system should be left on. The forced draft of these fans assists the movement of the liquid agent through the ventilating system, thus aiding in the fire suppression process. These fans also provide a cooling effect in the plenum and duct after the fire suppression system has been discharged. The system is UL listed with or without fan operation.

It is also recommended that make up or supply air fans be shut down upon system actuation. Shutdown of fuel and power to all appliances located under protected ventilating equipment is required upon system actuation.

UL LISTING

The R-102 Restaurant Fire Suppression System has been tested and is listed by Underwriters Laboratories, Inc. as a pre-engineered system. These tests require extinguishment of fires which are initiated in deep fat fryers, griddles, char-broilers, upright broilers, chain-broilers, filters, plenum chambers, hoods, and ducts after pre-loading each appliance with a prescribed amount of cooking grease. Each fire is allowed to progress to maximum intensity before the fire suppression system is actuated.

DEFINITION OF TERMS

Actuation Gas Line: Piping from the ANSUL AUTOMAN Regulated Release Assembly which supplies nitrogen or carbon dioxide to the Regulated Actuator Assembly for multiple-tank system actuation.

Agent Tank: A pressure vessel containing the liquid agent.

ANSUL AUTOMAN Regulated Release Assembly (Electrical): An assembly which contains the regulated release mechanism, agent tank, expellant gas hose, solenoid, and electric switch within a metal enclosure. The enclosure contains knockouts to facilitate component hookups.

ANSUL AUTOMAN Regulated Release Assembly (Mechanical): An assembly which contains the regulated release mechanism, agent tank, and expellant gas hose within a metal enclosure. The enclosure contains knockouts to facilitate component hookups.

Authority Having Jurisdiction: The "authority having jurisdiction" is the organization, office, or individual responsible for "approving" equipment, an installation, or a procedure. The phrase "Authority Having Jurisdiction" is used in a broad manner since jurisdictions and "approval" agencies vary as do their responsibilities. Where public safety is primary, the "authority having jurisdiction" may be a federal, state, local, or other regional department or individual such as a fire chief, fire marshal, chief of a fire prevention bureau, labor department, health department, building official, electrical inspector, or others having statutory authority. For insurance purposes, an insurance company representative may be the "authority having jurisdiction." In many circumstances the property owner or his designated agent assumes the role of the "authority having jurisdiction;" at government installations, the commanding officer or departmental official may be the "authority having jurisdiction."

Blow-Off Cap: A cap which covers the end of the nozzle tip and prevents grease from plugging the nozzle orifice.

Branch Line: The agent distribution piping which extends from the supply line to the nozzle(s).

Bursting Disc: A disc installed in the tank adaptor which eliminates the siphoning of the agent up the pipe during extreme temperature variations.

Cartridge: A sealed, steel pressure vessel containing nitrogen or carbon dioxide gas used to pressurize the agent tank.

Cooking Appliance: Includes fryers, griddles, ranges, upright broilers, chain broilers, natural charcoal broilers, or char-broilers (electric, lava rock, gas-radiant, or mesquite).

Conduit Offset Assembly: A pre-formed piece of conduit which can be installed between the Ansul regulated release and the conduit to allow the wire rope for the detection, gas valve and remote manual pull station to be installed in a more convenient manner.

AGENT DATA SHEET

LIQUID FIRE SUPPRESSANT

FEATURES

- Fast Flame Knock-Down and Securement of Grease-Related Fires
- Provides a Cooling Effect Which Further Enhances Its Ability to Prevent Reflash
- Designed for a Wide Variety of Restaurant Hazards
- Listed by Underwriters Laboratories, Inc. (UL) as Part of the R-102 Restaurant System
- Ease of Recharge and Post-Fire Cleanup
- Non-Corrosive

APPLICATION

ANSULEX Low pH Liquid Fire Suppressant is designed for use only in Ansul R-102 restaurant fire suppression systems. This "liquid" agent will combat grease-related fires as found in restaurant appliances and ventilating equipment. It should **not** be used for fires involving energized electrical hazards.

DESCRIPTION

ANSULEX Low pH Liquid Fire Suppressant is a specially-formulated, aqueous solution of organic salts. The agent is pre-mixed, eliminating the need for dilution before system charging. When used as an extinguishing agent, it will produce no toxic by-products.

AGENT PROPERTIES

Appearance Color-Coded
Fluorescent
Yellow-Green

Storage Life 12 Years

Refractive Index 1.4040

Freeze Point -40 °F (-40 °C)

Boiling Point 230 °F (110 °C)

Specific Gravity 1.32

Kinematic Viscosity 5.26 centistokes

pH 7.8 - 8.2

WARNING: Care should be taken when handling the agent. If contact is made with the eyes or skin, flush with water. If the agent is swallowed, dilute with water or milk and contact a physician.

PERFORMANCE

When used in the Ansul R-102 restaurant system, ANSULEX Low pH Liquid Fire Suppressant is extremely effective on fires in restaurant ventilating equipment - hoods and ductwork, as well as in a variety of cooking appliances - deep-fat fryers, griddles, range tops, and several types of broilers and char-broilers.

As the agent is sprayed in fine droplets (atomized) onto an appliance grease fire, it provides excellent flame knock-down, surface-cooling, and fire-securing capabilities. When the agent reacts with the hot grease, it forms a layer of foam on the surface of the fat. This soap-like blanket of foam acts as an insulator between the hot grease and the atmosphere, helping to prevent flammable vapors from escaping and reducing the chance for flame reignition.

Post-fire cleanup can be readily accomplished by flushing the area with water or steam.

Because of the composition of ANSULEX Low pH Liquid Fire Suppressant, it is compatible with metals commonly found in restaurant kitchen environments (i.e., stainless steel, aluminum, galvanized metal, mild steel, copper and brass).

APPROVALS AND LISTINGS

ANSULEX Low pH Liquid Fire Suppressant has been tested, and is listed with Underwriters Laboratories, Inc. (EX-3470) as part of the Ansul R-102 Restaurant Fire Suppression System.

ORDERING INFORMATION

ANSULEX Low pH Liquid Fire Suppressant is available in sealed containers.

Part No. 79694 1.5 gallon (5.7 L)
Part No. 79372 3.0 gallon (11.4 L)

Recharge services are available from Ansul-authorized distributors.

ANSUL is a registered trademark and ANSULEX is a trademark.

SYSTEM DESIGN

The R-102 and the PIRANHA systems use compatible agents and components, therefore, they may be used together for cooking appliance, hood, and duct protection. The primary ANSUL AUTOMAN Release can be either an R-102 or a PIRANHA ANSUL AUTOMAN Release and can actuate up to two additional R-102 or PIRANHA Regulated Actuators. In systems utilizing a 101 remote release, any combination of the maximum number of regulated actuators can be used.

- Both systems must actuate simultaneously
- Each system must be designed and installed per its appropriate manual.
- Adjacent appliances requiring protection must be protected with the same type of system, either R-102 or PIRANHA, unless the center-to-center spacing between the adjacent R-102 and PIRANHA nozzles is no less than 36 inches.
- When appliances are protected with R-102 nozzles, the hood and connecting duct above those appliances cannot be protected with PIRANHA nozzles.
- Mixing systems in a common plenum is not allowed.

The Ansul R-102 Restaurant Fire Suppression System may be used on a number of different types of restaurant cooking appliances and hood and duct configurations. The design information listed in this section deals with the limitations and parameters of this pre-engineered system. Those individuals responsible for the design of the R-102 system must be trained and hold a current Annual certificate in an R-102 training program.

One of the key elements for restaurant fire protection is a correct system design. This section is divided into ten sub-sections: Nozzle Placement Requirements, Tank Quantity Requirements, Actuation and Expellant Gas Line Requirements, Distribution Piping Requirements, Detection System Requirements, Manual Pull Station Requirements, Mechanical Gas Valve Requirements, Electrical Gas Valve Requirements, Electrical Switch Requirements, and Pressure Switch Requirements. Each of these sections must be completed before attempting any installation. System design sketches should be made of all aspects of design for reference during installation.

NOZZLE PLACEMENT REQUIREMENTS

This section gives guidelines for nozzle type, positioning, and quantity for plenum, duct, and individual appliance protection. This section must be completed before determining tank quantity and piping requirements.

Duct Protection

All duct protection is UL approved without limitation of maximum duct length (unlimited length). This includes all varieties of duct-works both horizontal and vertical including ducts that run at angles to the horizontal and ducts with directional bends.

The R-102 system uses several different duct nozzles depending on the size of duct being protected

1W Nozzle (Part No. 419336) – 1.5 Gallon and 3.0 Gallon Systems:

The R-102 systems, both 1.5 gallon and 3.0 gallon, use the 1W nozzle (Part No. 419336) for duct protection of 27 in. (68.6 cm) perimeter or less or 8.5 in. (21.6 cm) diameter or less. The nozzle tip is stamped with 1W, indicating that this is a one-flow nozzle and is to be counted as one flow number.

- Single Nozzle (One Flow Number) Duct Protection: One 1W nozzle (Part No. 419336) will protect ducts with a maximum perimeter of 27 in. (68.6 cm) or a maximum diameter of 8.5 in. (21.6 cm). The nozzle must be installed 2-8 in. (5-20 cm) into the center of the duct opening and positioned as shown in Figure 1.

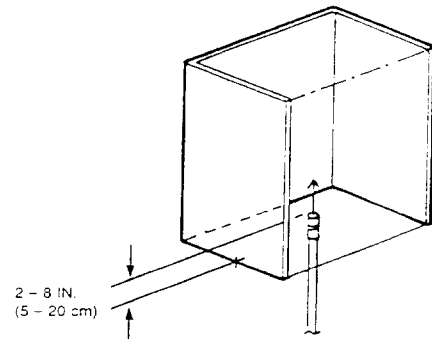

FIGURE 1
000173

- Single Nozzle (One Flow Number) Transition Protection: One 1W nozzle (Part No. 419336) will protect transitions where the perimeter of 27 in. (68.6 cm) or the diameter of 8.5 in. (21.6 cm) or less begins within that transition. The nozzle must be placed in the center of the transition opening where the maximum perimeter or diameter begins as shown in Figures 2 and 3.

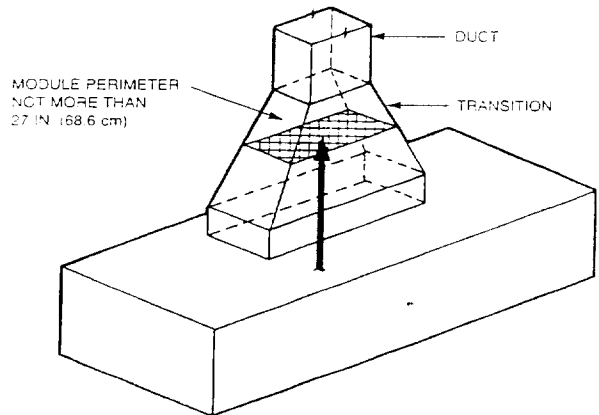

FIGURE 2
000174

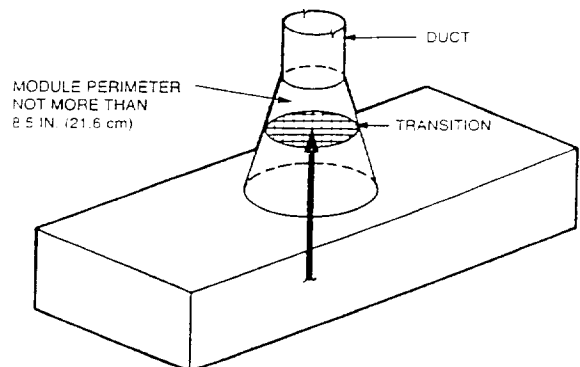

FIGURE 3
000175

NOZZLE PLACEMENT REQUIREMENTS (Continued)

Duct Protection (Continued)

NOTICE

A 2WH nozzle must be substituted for a 2W nozzle for any installation using Option 2 of the 1.5 gallon system coverage (6 flow duct and plenum protection only).

2W Nozzle (Part No. 419337):

The R-102 System, uses the 2W nozzle (Part No. 419337) for duct protection of 75 in. (190.5 cm) perimeter or less, or 24 in. (61 cm) diameter or less. The nozzle tip is stamped with 2W, indicating that this is a two-flow nozzle and must be counted as two flow numbers.

The 1W and 2W nozzles will protect the following:

3. Single Nozzle (2W) Duct Protection:

One 2W nozzle will protect ducts with a maximum perimeter of 75 in. (190.5 cm) or a maximum diameter of 24 in. (61 cm). The nozzle must be installed 2-8 in. (5-20 cm) into the center of the duct opening and positioned as shown in Figure 4.

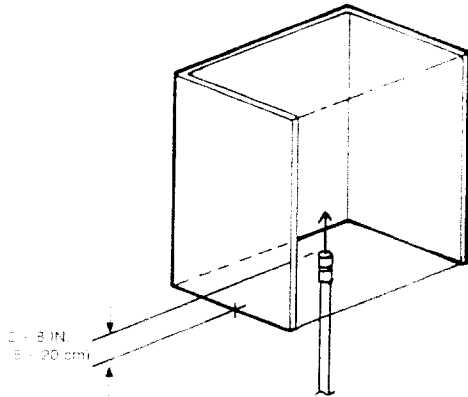

FIGURE 4
000173

4. Single Nozzle (2W) Transition Protection:

One 2W nozzle will protect transitions at the point where the perimeter of 75 in. (190.5 cm) or the diameter of 24 in. (61 cm) or less begins within that transition. The nozzle must be placed in the center of the transition opening where the maximum perimeter or diameter begins as shown in Figures 5 and 6.

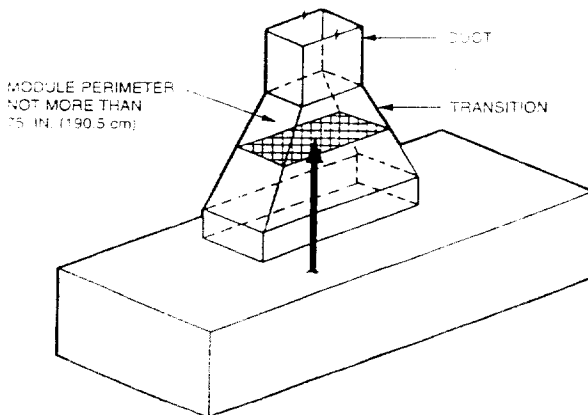

FIGURE 5
000174

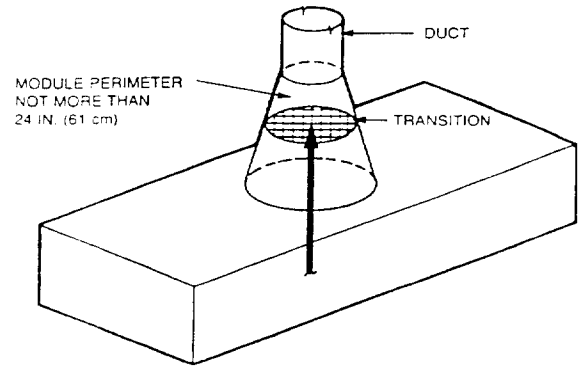

FIGURE 6
000175

5. Dual-Nozzle Duct Protection:

Two 2W nozzles will protect ducts with a maximum perimeter of 150 in. (381 cm) or a maximum diameter of 48 in. (122 cm). The nozzles must be installed 2-8 in. (5-20 cm) into the duct opening and positioned as in Figure 7.

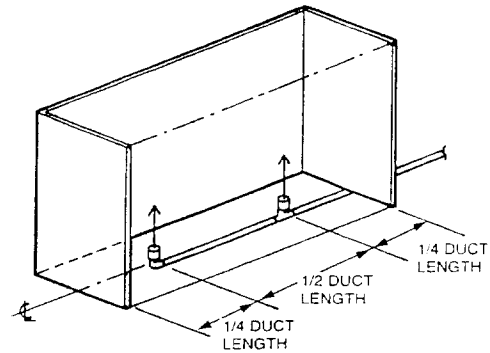

FIGURE 7
000176

NOTICE

In installations where a UL listed damper assembly is employed, the duct nozzle can be installed beyond the 8 in. (20 cm) maximum, to a point just beyond the damper assembly that will not interfere with the damper. Exceeding the maximum of 8 in. (20 cm) in this way will not void the UL listing of the system.

NOZZLE PLACEMENT REQUIREMENTS (Continued)

Duct Protection (Continued)

6 Dual-Nozzle Transition Protection

Two 2W nozzles will protect transitions with a maximum perimeter of 150 in. (381 cm). The transition area must be divided where two equally sized modules begin within that transition. The nozzle must be placed in the center of the transition opening where the maximum module perimeter begins as shown in Figure 8.

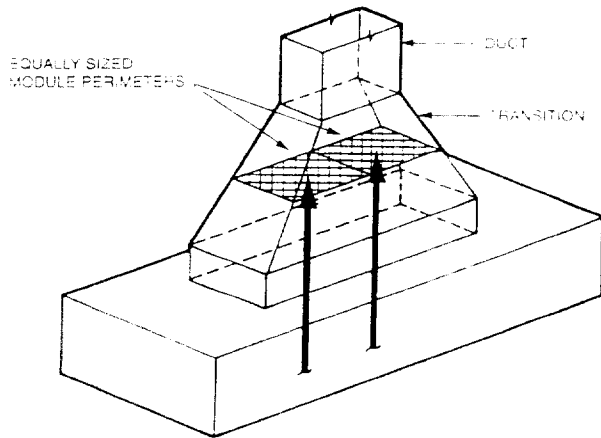

FIGURE 8
000177

7 Dual-Nozzle Duct Protection (3 Flow Numbers):

Rectangular ducts larger than 75 in. (191 cm) perimeter, up to a maximum of 102 in. (260 cm) perimeter, (diameters larger than 24 in. (61 cm), up to 32 in. (81 cm) diameter) can be protected with a combination of one 1W nozzle (Part No. 419336) and one 2W nozzle (Part No. 419337). Each nozzle must be installed on its own duct branch line and positioned 2-8 in. (5-20 cm) into the center of the duct. See Figure 9.

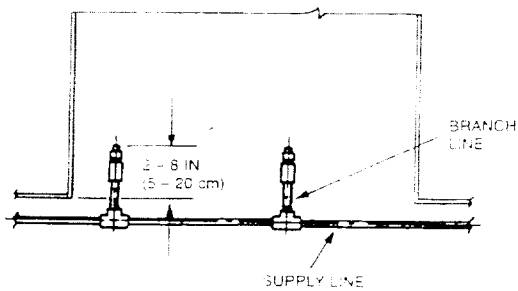

FIGURE 9
000178

To correctly locate the nozzles in the duct, the longest side of the duct must be divided into four equal modules. See Figure 10.

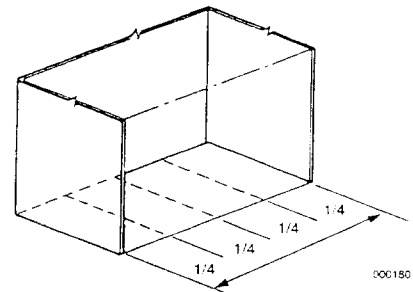
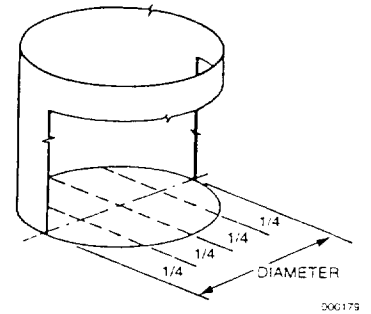

FIGURE 10

The 1W nozzle (Part No. 419336) is then centered in one of the outside modules. See Figure 11.

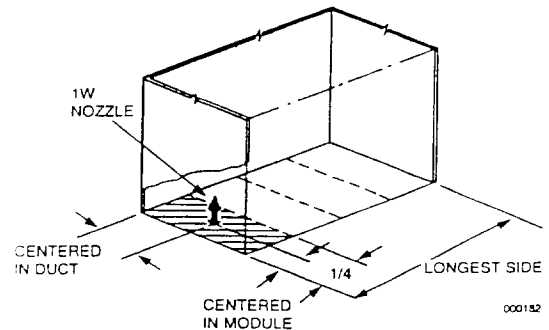
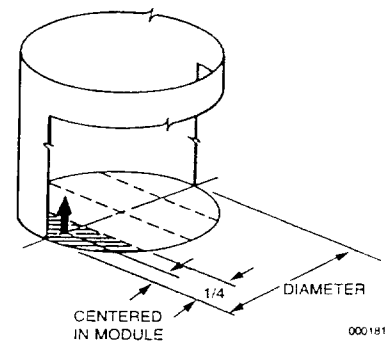

FIGURE 11

NOZZLE PLACEMENT REQUIREMENTS (Continued)

Duct Protection (Continued)

7 (Continued)

The 2W nozzle (Part No. 419337) is then centered in the remaining three modules. See Figure 12

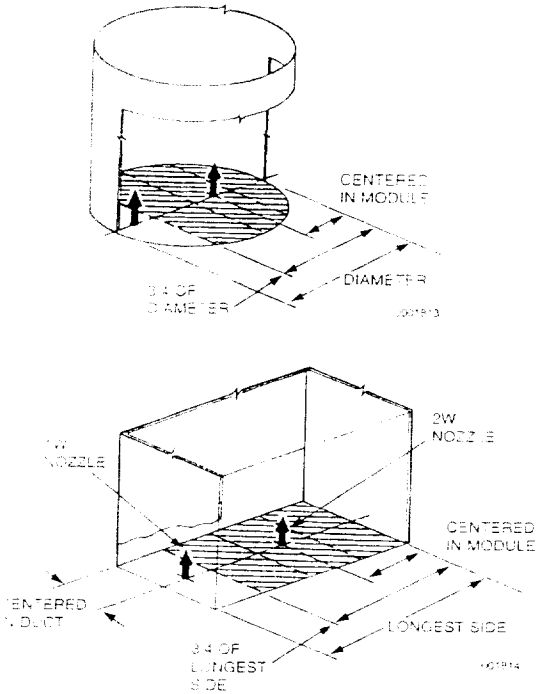

FIGURE 12

The nozzles must be positioned on the same centerline parallel to the longest side. See Figure 13.

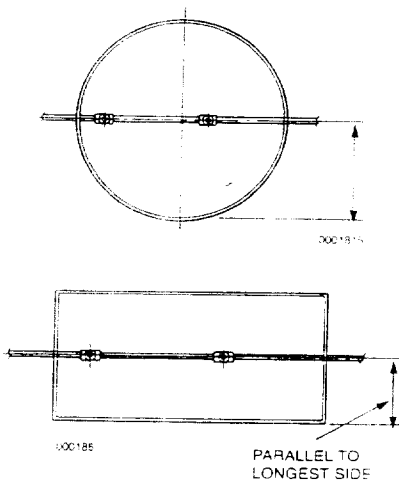

FIGURE 13

8. Triple-Nozzle Duct Protection (5 Flow Numbers):

NOTICE

When protecting the duct with a 1.5 gallon system using this type of protection, no appliance branch lines are allowed on the 1.5 gallon system.

Rectangular/square ducts larger than 150 in. (381 cm) perimeter, up to a maximum of 177 in. (450 cm) perimeter, may be protected with a combination of one 1W nozzle (Part No. 419336) and two 2W nozzles (Part No. 419337). Each nozzle must be installed on its own duct branch line and positioned 2-8 in. (5-20 cm) into the center of the duct. See Figure 14.

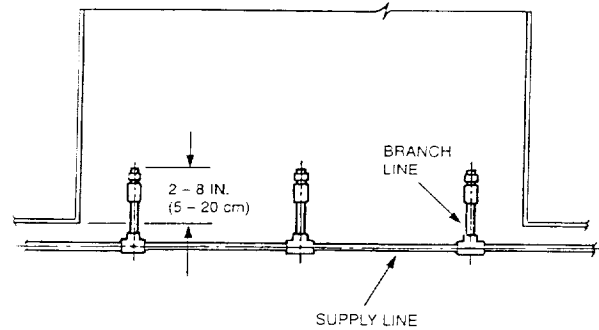

FIGURE 14
000187

To determine if this type of protection can be used, first divide the longest side of the duct in half. See Figure 15.

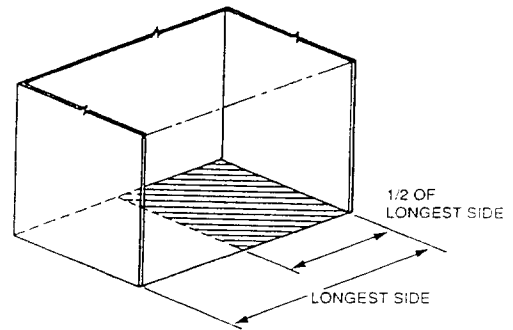

FIGURE 15
000188

NOZZLE PLACEMENT REQUIREMENTS (Continued)
Plenum Protection (Continued)

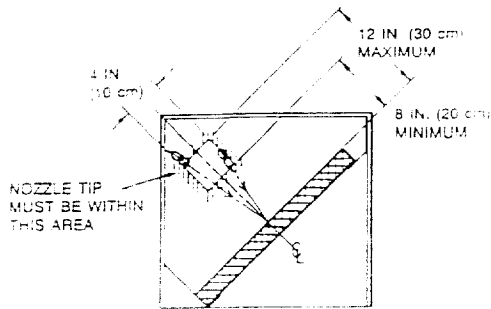

FIGURE 26

Exception: When the plenum chamber contains filters that do not exceed 10 in. (25.4 cm) in height and the 1N nozzle can be installed at the intersecting center lines of both filter banks and not exceed the 2-4 in. (5 to 10 cm) distance from either filters, a single 1N nozzle can be used. See Figure 27a.

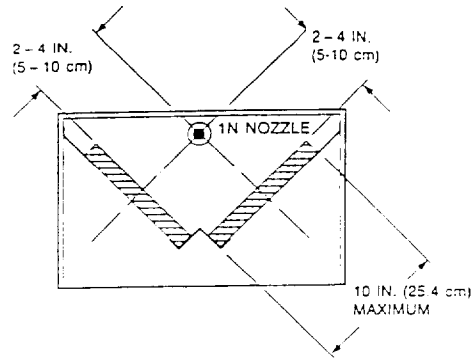

FIGURE 27a

NOTICE

If 1N nozzle coverage does not exceed 7 linear ft. (2.1 m), the nozzle can be mounted 2 to 6 in. (5-15 cm) from the face of the filter.

For a plenum, either single or "V" bank, with a linear extension longer than 8 feet (2.4 m), each bank may be protected using one 1N nozzle every 8 ft. (2.4 m) or less depending on the overall length of the plenum. See Figure 28. The nozzles may point in the opposite directions as long as the entire plenum area is protected, and the 8 ft. (2.4 m) limitation is not exceeded. See Figure 29. The nozzle positioning shown in Figure 30 is not an acceptable method of protection because the plenum area directly under the tee is not within the discharge pattern of either nozzle.

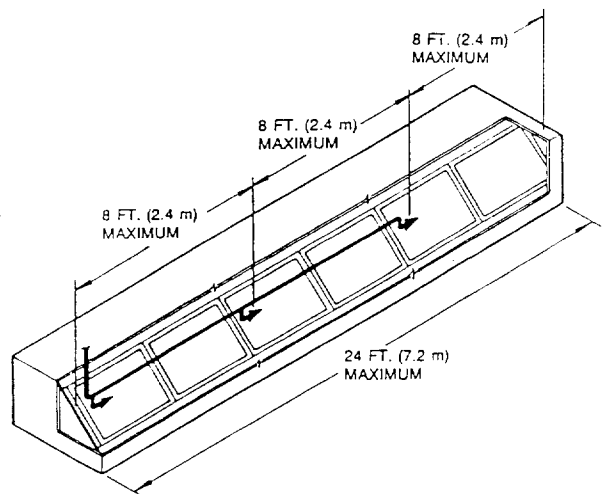

FIGURE 28

▶ **1N NOZZLE – PART NO. 419335**

One 1N nozzle will protect 8 linear feet (2.4 m) of single filter bank plenum or two 1N nozzles will protect 8 linear feet (2.4 m) of "V" bank plenum. In either application, the nozzle(s) must be mounted in the plenum, 2 to 4 in. (5 to 10 cm) from the face of the filter, centered between the filter height dimension, and aimed down the length. The filter height must not exceed 20 in. (51 cm). See Figure 27.

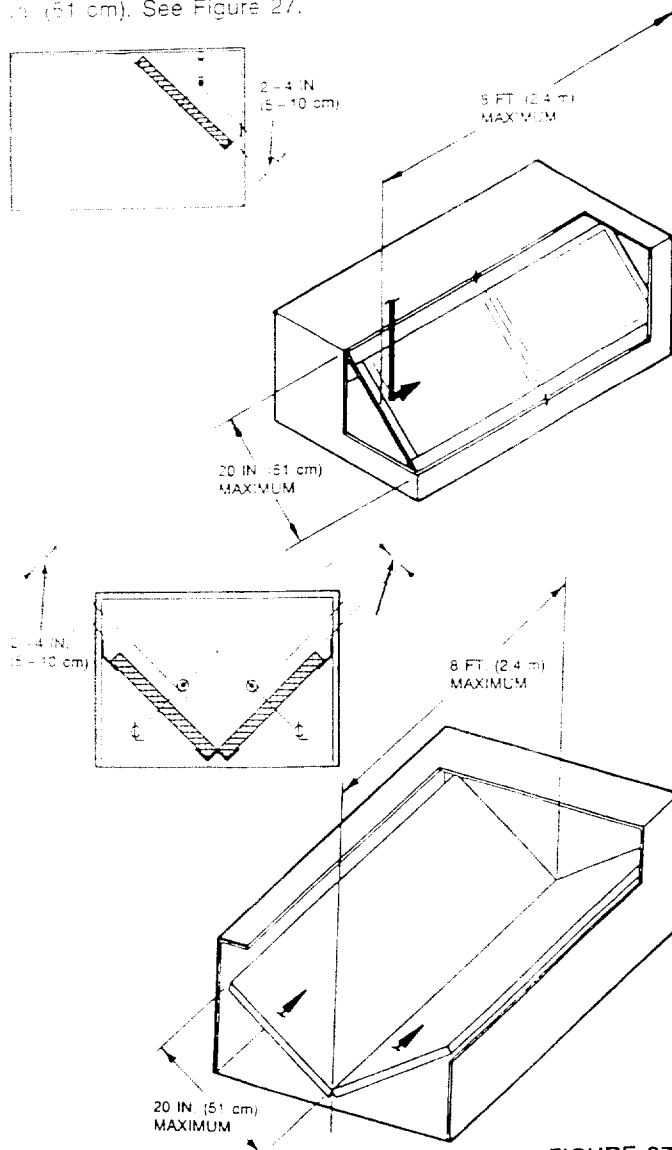

FIGURE 27

NOZZLE PLACEMENT REQUIREMENTS (Continued)
Plenum Protection (Continued)

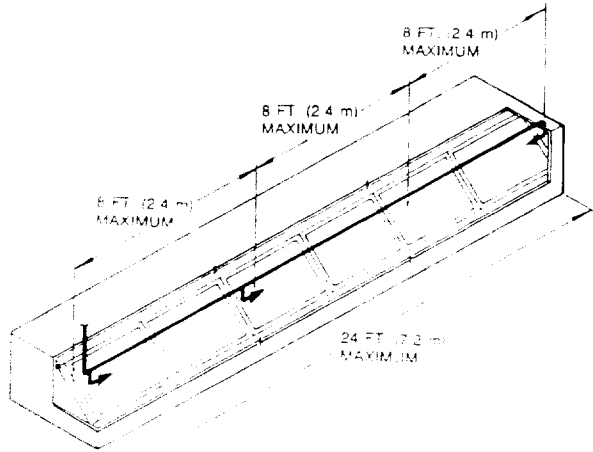

FIGURE 29

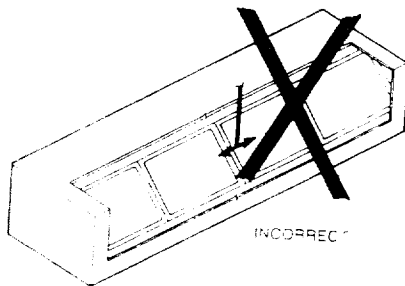

FIGURE 30

The following pages detail types of appliance protection. Each design requires several factors: correct nozzle choice, correct nozzle height above hazard, correct nozzle location and correct aiming point.

When protecting appliances which are larger than single nozzle coverage, multiple nozzles can be used.

Larger appliances can be divided into several modules, each equal to or smaller than single nozzle coverage. Exception: Fryers must not exceed a maximum of 864 sq. in. (5574 sq. cm).

Single Nozzle Fryer Protection – 2-Flow High Proximity/ 2-Flow Medium Proximity

If the fryer **does not** have a drip board, the maximum hazard (fry pot) size is 15 in. (38 cm) x 14 in. (36 cm) (maximum area of 210 sq. in. (1355 sq. cm)). If the fryer **has** a drip board, the maximum hazard (cooking surface) size is 21 in. (53 cm) x 14 in. (36 cm) (maximum area of 294 sq. in. (1897 sq. cm)). The maximum fryer pot size must still not exceed 15 in. (38 cm) x 14 in. (36 cm) (210 sq. in. (1355 sq. cm) of maximum area.) The nozzle must be aimed at the center of the hazard area.

The R-102 system uses two different style nozzles for the protection of fryers.

1. **High Proximity Applications:** 27 to 47 in. (68 to 119 cm) above the top surface of fryer. See Figure 31a and Figure 31b.

► The 230 Nozzle (Part No. 419339) is used for high proximity applications. The nozzle tip is stamped with 230, indicating that this is a two-flow nozzle and must be counted as two flow numbers.

When using this nozzle for fryer protection, the nozzle tip must be positioned anywhere along or within the perimeter of the maximum hazard area and angled to the center.

FRYER WITH DRIP BOARD:
 MAXIMUM DIMENSIONS 21 IN. (53 cm) x 14 IN. (36 cm)
 MAXIMUM AREA 294 SQ. IN. (1897 sq. cm)

FRY POT:
 MAXIMUM DIMENSIONS 15 IN. (38 cm) x 14 IN. (36 cm)
 MAXIMUM AREA IS 210 SQ. IN. (1354 sq. cm)

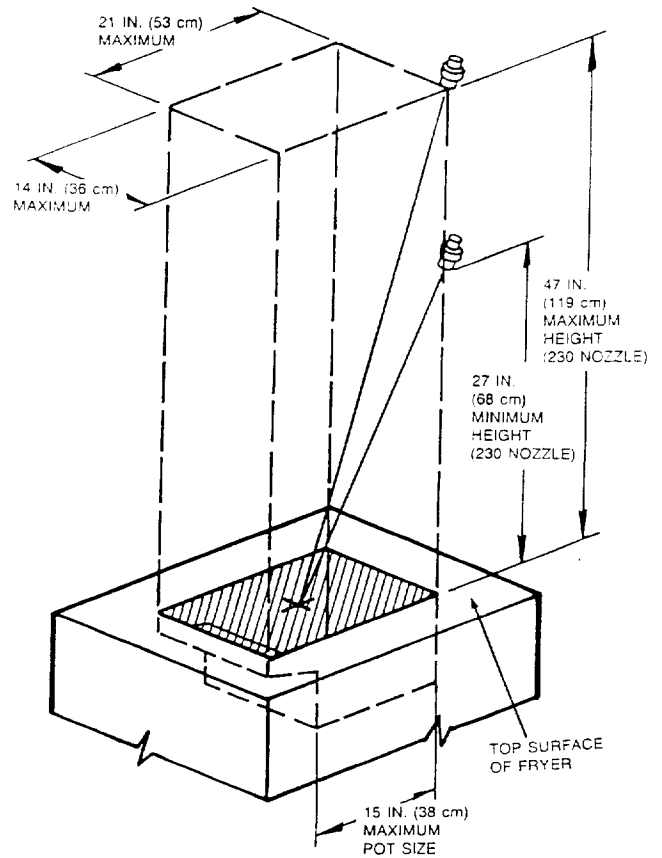

230 NOZZLE TIP POSITIONED ANYWHERE ALONG OR WITHIN PERIMETER OF COOKING SURFACE AND AIMED TO THE CENTER OF THE COOKING SURFACE.

FIGURE 31a

NOZZLE PLACEMENT REQUIREMENTS (Continued)

Range Protection (Continued)

2. **High Proximity Application (Two-Flow Nozzle):** 40 in. to 50 in. (102 cm to 127 cm) above the cooking surface.

The high proximity application uses the 245 nozzle, Part No. 419340.

The nozzle tip is stamped with 245 indicating this is a two-flow nozzle and must be counted as two flow numbers.

One 245 nozzle will protect a cooking area of 672 sq. in. (4335 sq. cm) with maximum dimensions of 28 in. x 24 in. (71 cm x 61 cm).

When using this nozzle for range protection, the nozzle must be pointed vertically down and positioned as shown in Figures 35 and 36.

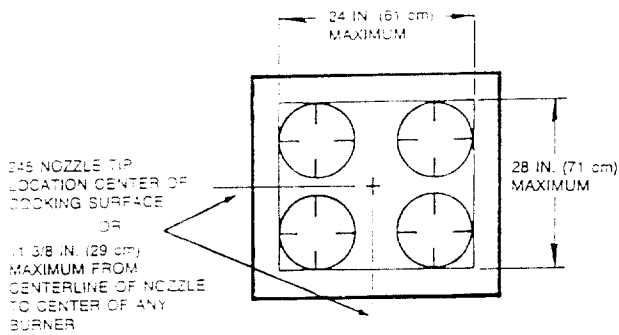
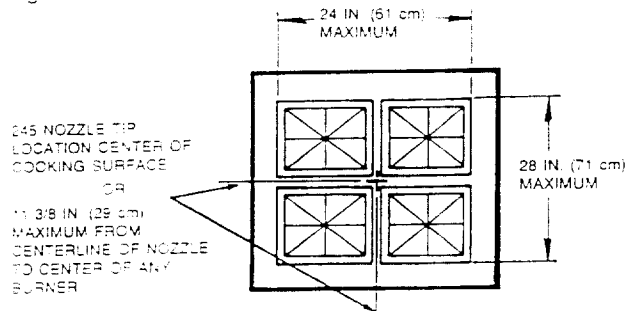

FIGURE 35

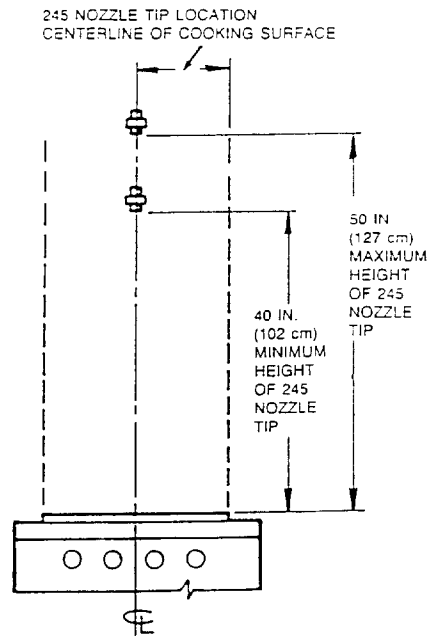
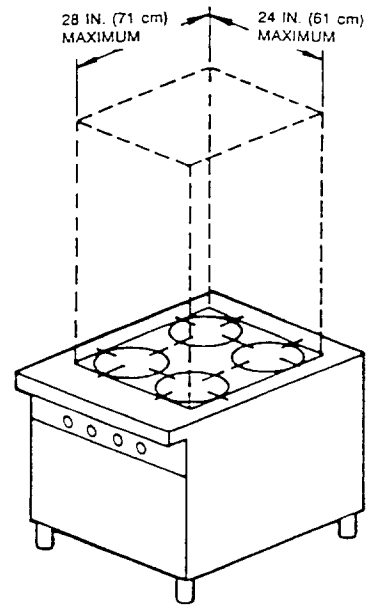

FIGURE 36

NOTICE

Four burners shown in Figure 35. For single or double burners, locate nozzle at center of cooking surface or 11 3/8 in. (29 cm) maximum from nozzle centerline to center of any burner.

SECTION IV – SYSTEM DESIGN

NOZZLE PLACEMENT REQUIREMENTS (Continued)

Two-Flow Griddle Protection (Continued)

2. High Proximity Application: (Nozzle Perimeter Located) 30 in. to 50 in. (76 cm to 127 cm) above the cooking surface.

This high proximity application uses the 260 nozzle. Part No. 419341.

The nozzle tip is stamped with 260 indicating this is a two-flow nozzle and must be counted as two flow numbers.

One 260 nozzle will protect a cooking area of 1440 sq. in. (9290 sq. cm) with maximum dimensions of 30 in. x 48 in. (76 cm x 122 cm).

When using this nozzle for griddle protection, the nozzle must be positioned along the cooking surface perimeter to 2 in. (5.1 cm) inside perimeter, and aimed at the center of the cooking surface. See Figure 41a and 41b.

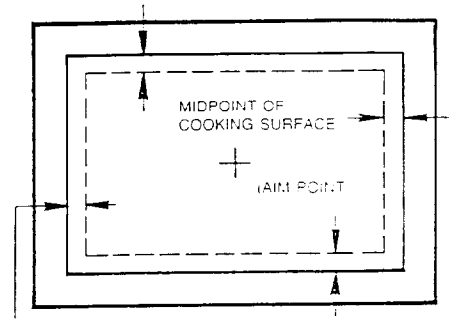

260 NOZZLE LOCATED ALONG ANY SIDE OF GRIDDLE SURFACE WITHIN 0 - 2 IN. (0 - 5.1 CM) OF COOKING SURFACE EDGE. NOZZLE MUST BE AIMED AT MIDPOINT OF COOKING SURFACE.

FIGURE 41b

3. Medium Proximity Application: (Nozzle Perimeter Located) 20 in. to 30 in. (51 cm to 76 cm) above the cooking surface.

The medium proximity application uses the 290 nozzle. Part No. 419342.

The nozzle tip is stamped with 290 indicating this is a two-flow nozzle and must be counted as two flow numbers.

One 290 nozzle will protect a cooking area of 1440 sq. in. (9290 sq. cm) with maximum dimensions of 30 in. x 48 in. (76 cm x 122 cm).

When using this nozzle for griddle protection, the nozzle must be positioned along the perimeter to 2 in. (5.1 cm) inside perimeter, and aimed at the center of the cooking surface. See Figure 42 and 43.

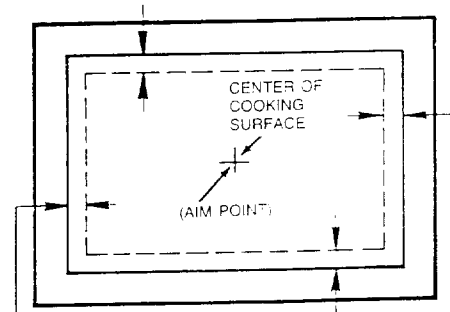

290 NOZZLE LOCATED ALONG ANY SIDE OF GRIDDLE SURFACE WITHIN 0 - 2 IN. (0 - 5.1 CM) OF COOKING SURFACE EDGE. NOZZLE MUST BE AIMED AT CENTER OF COOKING SURFACE.

FIGURE 42

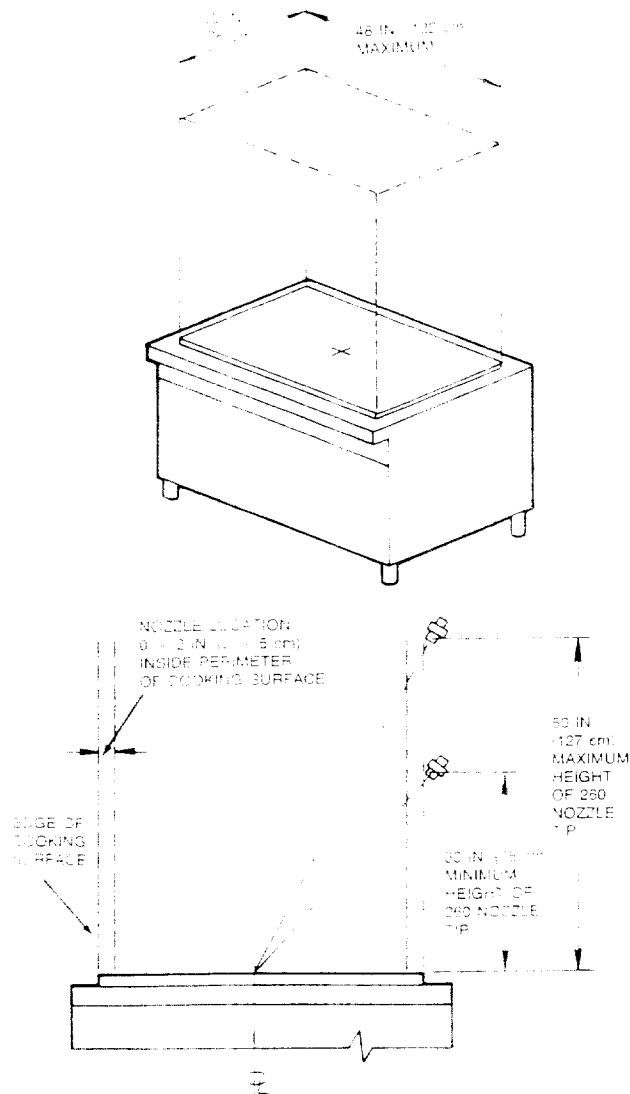

FIGURE 41a

DISTRIBUTION PIPING REQUIREMENTS (Continued)

Distribution Piping Requirements – 3.0 Gallon System

1. The maximum length between the start of the first branch line and the start of the last branch line must not exceed 24 ft. (7.3 m). When the supply line is split, the **combined total** of both legs of the supply line (from the start of the first branch line to the start of the last branch line) must not exceed 24 ft. (7.3 m). See Figure 88.
2. The total length of all branch lines must not exceed 36 ft. (10.9 m). See Figure 88.
3. Use a 3/8 in. union to connect the tank adaptor to the 3/8 in. supply line.
4. A maximum of two nozzles are allowed per duct branch line.
5. The requirements of the following table must not be exceeded:

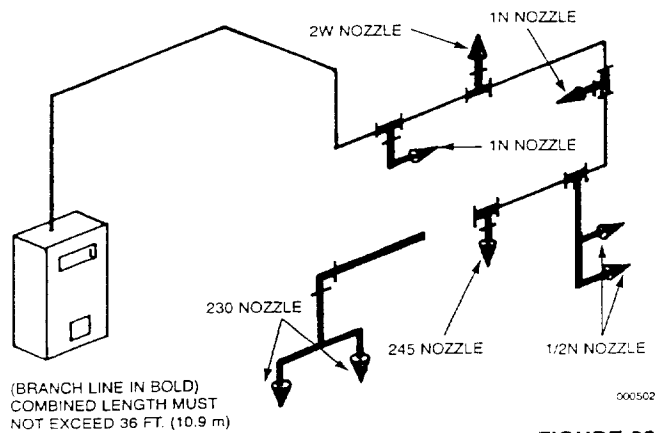
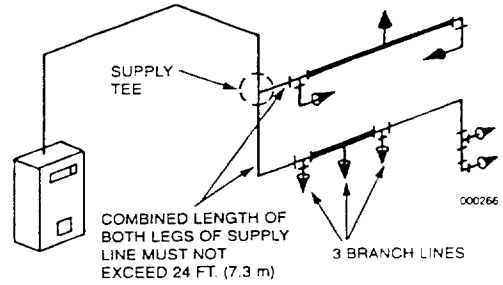

FIGURE 88

<u>Requirements</u>	<u>Supply Line</u>	<u>Duct Branch Line</u>	<u>Plenum Branch Line</u>	<u>Appliance Branch Line</u>
Pipe Size	3/8 in.	3/8 in.	3/8 in.	3/8 in.
Maximum Length	40 ft. (12.2 m)	8 ft. (2.4 m)	4 ft. (1.2 m)	12 ft. (3.7 m)
Maximum Rise	6 ft. (1.8 m)	4 ft. (1.2 m)	2 ft. (.6 m)	2 ft. (.6 m)
Maximum 90° Elbows	9	4	4	6
Maximum Tees	1	2	2	4
Maximum Flow Numbers	11*	4	2	4

Exceptions:

1. Twelve (12) flow numbers are allowed in any one tank not containing two-flow appliance nozzles, and/or, a 1N nozzle for wok or griddle protection, and/or, a 1F nozzle for range protection, and/or, a 3N nozzle for fryer protection.
2. Twelve (12) flow numbers are allowed with any one tank using only two-flow appliance nozzles.
3. Twelve (12) flow numbers are allowed with any one tank using only three-flow appliance nozzles.

Special Instructions:

1. Twelve (12) flow numbers are allowed when four (4) Dean Industries GTI Gas Fryers are protected at low proximity as shown in Figure 101 on Page 4-52. The discharge piping must be as shown in Figure 102 on Page 4-52.
2. For certain McDonald's applications, 11.5 flow numbers are allowed when using a combination of one (1) 2W duct nozzle, one (1) 1/2N electrostatic precipitator nozzle, one (1) 1N plenum nozzle, and four (4) two-flow appliance nozzles. Contact Ansul Applications Engineering Department for additional information.

NOZZLE PLACEMENT REQUIREMENTS (Continued)

Nozzle Application Chart (Continued)

<u>Hazard</u>	<u>Maximum Hazard Dimensions</u>	<u>Nozzle Quantity</u>	<u>Nozzle Heights</u>	<u>Nozzle Part No.</u>	<u>Nozzle Tip Stamping - Flow No.</u>
Fryer**	Maximum Size (without drip board) 19 1/2 in. (49.5 cm) x 19 in. (48.2 cm) Area - 370 1/2 sq. in. (2390 sq. cm) Maximum				
	High Proximity	1	21 - 34 in.	419338	3N
	Low Proximity	1	13 - 16 in.	419342	290
	Maximum Size (with drip board) 25 3/8 in. (64.4 cm) Area - 495 sq. in. (3194 sq. cm) Maximum (Fry pot side must not exceed 19 1/2 in. (49.5 cm) x 19 in. (48.2 cm)				
	High Proximity	1	21 - 34 in.	419338	3N
	Low Proximity	1	13 - 16 in.	419342	290
Range	Longest Side 28 in. (71 cm) Area - 336 sq. in. (2168 sq. cm)	1	30 - 50 in. (76 - 127 cm) 40 - 48 in. (102 - 122 cm) (With Backshelf)	419333	1F
	Longest Side (High Proximity) 28 in. (71 cm) Area - 672 sq. in. (4335 sq. cm)	1	40 - 50 in. (102 - 127 cm)	419340	245
	Longest Side (Medium Proximity) 28 in. (71 cm) Area - 672 sq. in. (4335 sq. cm)	1	30 - 40 in. (76 - 102 cm)	419341	260
	Longest Side (Low Proximity) 36 in. (91 cm) Area - 1008 sq. in. (6503 sq. cm)	2	15 - 20 in. (38 - 51 cm)	419342	290
Griddle	Longest Side (High Proximity) 48 in. (122 cm) Area - 1440 sq. in. (9290 sq. cm)	1	30 - 50 in. (76 - 127 cm) (perimeter located)	419341	260
	Longest Side (High Proximity) 30 in. (76 cm) Area - 720 sq. in. (4645 sq. cm)	1	30 - 50 in. (76 - 127 cm) (center located)	419342	290
	Longest Side (High Proximity) 36 in. (91 cm) Area - 1080 sq. in. (7000 sq. cm)	1	35 - 40 in. (89 - 102 cm) (perimeter located)	419335/417332	1N/1NSS
	Longest Side (Medium Proximity) 48 in. (122 cm) Area - 1440 sq. in. (9190 sq. cm)	1	20 - 30 in. (51 - 76 cm) (perimeter located)	419342	290

**For multiple nozzle protection of single fryers, see detailed information on Pages 4-10.1 through 4-10.8

NOZZLE PLACEMENT REQUIREMENTS (Continued)

Nozzle Application Chart (Continued)

<u>Hazard</u>	<u>Maximum Hazard Dimensions</u>	<u>Nozzle Quantity</u>	<u>Nozzle Heights</u>	<u>Nozzle Part No.</u>	<u>Nozzle Tip Stamping – Flow No.</u>
▶ Griddle (Continued)	Longest Side (Low Proximity) 48 in. (122 cm) Area – 1440 sq. in. (9290 sq. cm)	1	10 – 20 in. (25 – 51 cm) (perimeter located)	419343	2120
▶ Chain Broiler* (Overhead Protection)	Longest Side – 34 in. (86 cm) Area – 1088 sq. in. (7019 sq. cm)	2	10 – 25 in. (25 – 66 cm)	419336/417333	1W/1WSS
▶ Chain Broiler (Horizontal Protection)	Length – 43 in. (109 cm) Width – 31 in. (79 cm)	2	1 – 3 in. (3 – 8 cm)	419335/417332	1N/1NSS
▶ Gas-Radiant Char-Broiler	Longest Side – 24 in. (61 cm) Area – 528 sq. in. (3406 sq. cm)	1	18 – 40 in. (46 – 102 cm)	419340	245
	Longest Side – 24 in. (61 cm) Area – 528 sq. in. (3406 sq. m)	1	26 – 40 in. (66 – 102 cm)	419335/417332	1N/1NSS
▶ Electric Char-Broiler	Longest Side – 34 in. (86 cm) Area – 680 sq. in. (4368 sq. cm)	1	20 – 50 in. (51 – 127 cm)	419335/417332	1N/1NSS
▶ Lava-Rock Broiler	Longest Side – 24 in. (61 cm) Area – 312 sq. in. (2013 sq. cm)	1	18 – 35 in. (46 – 89 cm)	419335/417332	1N/1NSS
▶ Natural Charcoal Broiler	Longest Side – 24 in. (61 cm) Area – 288 sq. in. (1858 sq. cm)	1	18 – 40 in. (46 – 102 cm)	419335/417332	1N/1NSS
▶ Lava-Rock or Natural Charcoal Char-Broiler	Longest Side – 30 in. (76 cm) Area – 720 sq. in. (4645 sq. cm)	1	14 – 40 in. (36 – 102 cm)	419338	3N
▶ Mesquite Char-Broiler	Longest Side – 30 in. (76 cm) Area – 720 sq. in. (4645 sq. cm)	1	14 – 40 in. (36 – 102 cm)	419338	3N
▶ Jorgit Broiler	Length – 32.5 in. (82.5 cm) Width – 30 in. (76 cm)	2	–	419334	1/2N
▶ Salamander Broiler	Length – 32.5 in. (82.5 cm) Width – 30 in. (76 cm)	2	–	419334	1/2N
▶ Nok	14 in. – 30 in. (36 – 76 cm) Diameter 3.75 – 8.0 in. (9.5 – 20 cm) Deep	1	35 – 45 in. (89 – 114 cm)	419341	260
▶	11 in. – 18 in. (28 – 46 cm) Diameter 3.0 – 5.0 in. (7.6 – 13 cm) Deep	1	35 – 40 in. (89 – 102 cm)	419335/417332	1N/1NSS
▶	11 in. – 24 in. (28 – 61 cm) Diameter 3.0 – 6.0 in. (8 – 15.2 cm) Deep		35 in. (89 cm)	419335/417332	1N/1NSS

*Minimum chain broiler exhaust opening – 12 in. x 12 in. (31 cm x 31 cm), and not less than 60% of internal broiler size.

NOZZLE PLACEMENT REQUIREMENTS (Continued)

Nozzle Application Chart

The following chart has been developed to assist in calculating the quantity and type of nozzle required to protect each duct, plenum, or appliance.

NOTICE

This chart is for general reference only. See complete details for each type of hazard.

Hazard	Maximum Hazard Dimensions	Nozzle Quantity	Nozzle Heights	Nozzle Part No.	Nozzle Tip Stamping – Flow No.
▶ Duct or Transition (Single Nozzle)	Length – Unlimited Perimeter – 27 in. (67 cm) Diameter – 8.5 in. (22 cm)	1	–	419336	1W
▶ Duct or Transition (Single Nozzle)	Length – Unlimited Perimeter – 75 in. (190.5 cm) Diameter – 24 in. (61 cm)	1	–	419337/78078*	2W/2WH*
▶ Duct or Transition (Dual Nozzle)	Length – Unlimited Perimeter – 150 in. (381 cm) Diameter – 48 in. (122 cm)	2	–	419337/78078*	2W/2WH*
▶ Electrostatic Precipitator (At Base of Duct)	Individual Cell	1	–	419334	1/2N
▶ Plenum (Horizontal Protection)	Length – 8 ft. (2.4 m) Filter Height – 20 in. (51 cm)	1	–	419335/417332	1N/1NSS
▶ Plenum (Vertical Protection)	Length – 4 ft. (1.2 m) Width – 4 ft. (1.2 m)	1	–	419336/417333	1W/1WSS
Fryer/Split Vat Fryer**	Maximum Size (without drip board) 15 in. (38 cm) x 14 in. (36 cm) Area – 210 sq. in. (1355 sq. cm) Maximum				
▶	High Proximity	1	27 – 47 in.	419339	230
▶	Medium Proximity	1	20 – 27 in.	419340	245
	Maximum Size (with drip board) 21 in. (53 cm) x 14 in. (36 cm) Area – 294 sq. in. (1897 sq. cm) Maximum (Fry Pot must not exceed 15 in. x 14 in. (38 cm x 36 cm))				
▶	High Proximity	1	27 – 47 in.	419339	230
▶	Medium Proximity	1	20 – 27 in.	419340	245

*Use 2WH nozzle on 1.5 gallon, 6 flow duct and plenum protection only.
 **For multiple nozzle protection of single fryers, see detailed information on Pages 4-10.1 through 4-10.3

ELECTRICAL SWITCH REQUIREMENTS (Continued)

Electric (110 VAC/60 Hz) Application with Customer Supplied Contactor and Heating Element Load, and Power Supply Switch
 INSTALLATION OVERVIEW

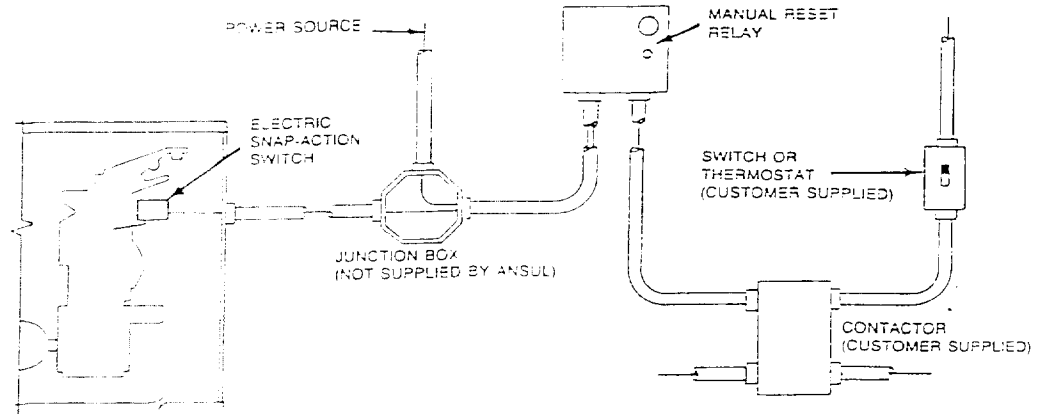

BASIC WIRING DIAGRAM

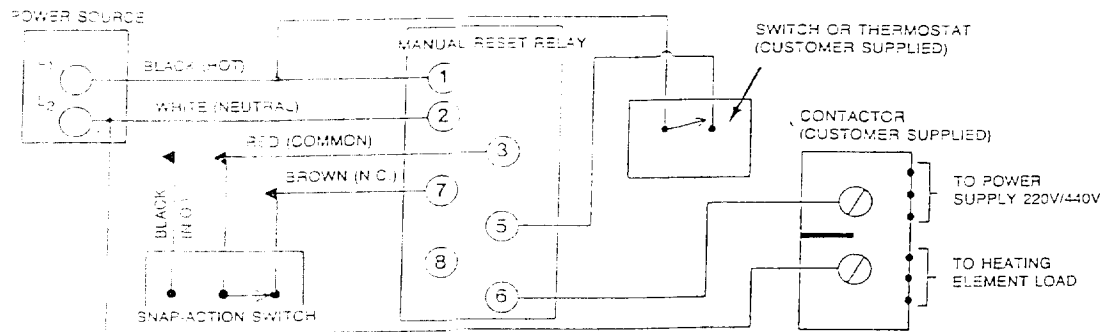

NOTE: DO NOT USE BLACK WIRE ON SNAP-ACTION SWITCH IN NORMAL INSTALLATION.
 BLACK WIRE TO BE USED ONLY FOR EXTRANEIOUS ALARM, LIGHT CIRCUIT, ETC

WIRING SCHEMATIC

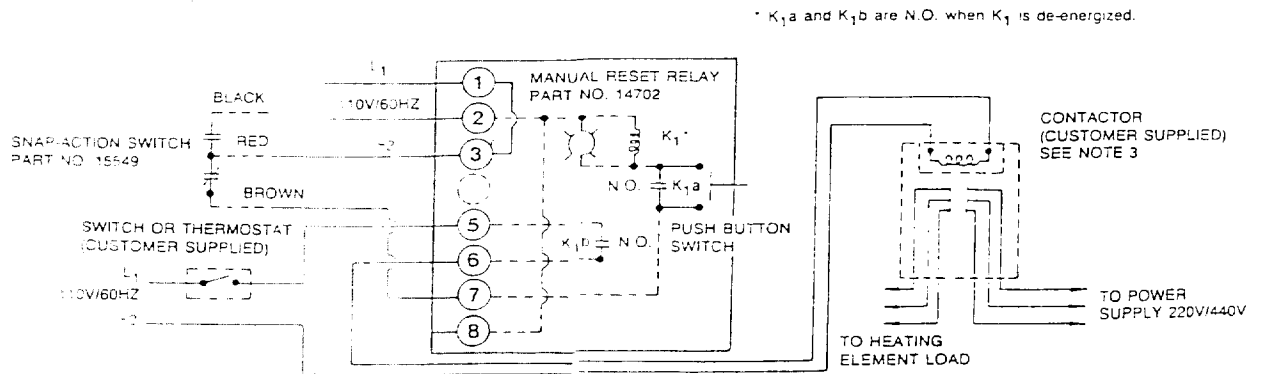

* K₁a and K₁b are N.O. when K₁ is de-energized.

NOTE:
 1. _____ DENOTES FIELD INSTALLATION
 2. _____ DENOTES FACTORY INSTALLATION
 3. CONTRACTORS: "ULL LISTED ENCLOSED INDUSTRIAL CONTROL EQUIPMENT OR MAGNETIC SWITCH HAVING A RATING MATCHING THAT OF THE COOKING APPLIANCE COIL 110V/60HZ"

FIGURE 82

ELECTRICAL SWITCH REQUIREMENTS (Continued)

Electric (110 VAC/60 Hz) Application with Customer Supplied Contactor and Heating Element Load
 INSTALLATION OVERVIEW

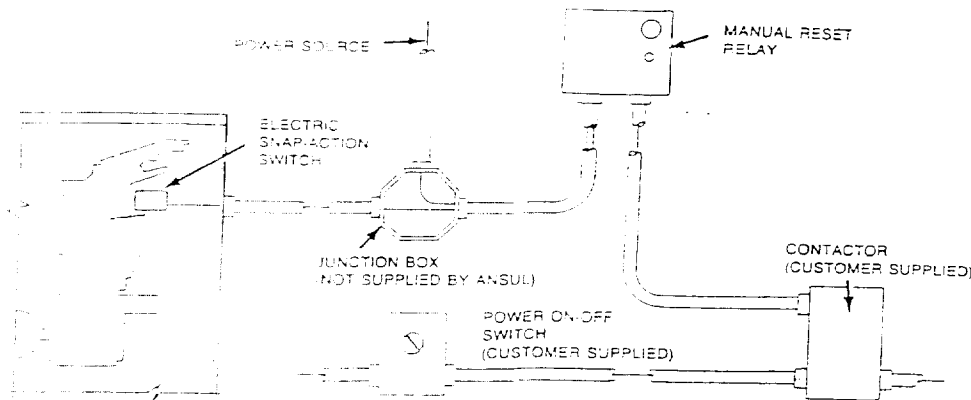

BASIC WIRING DIAGRAM

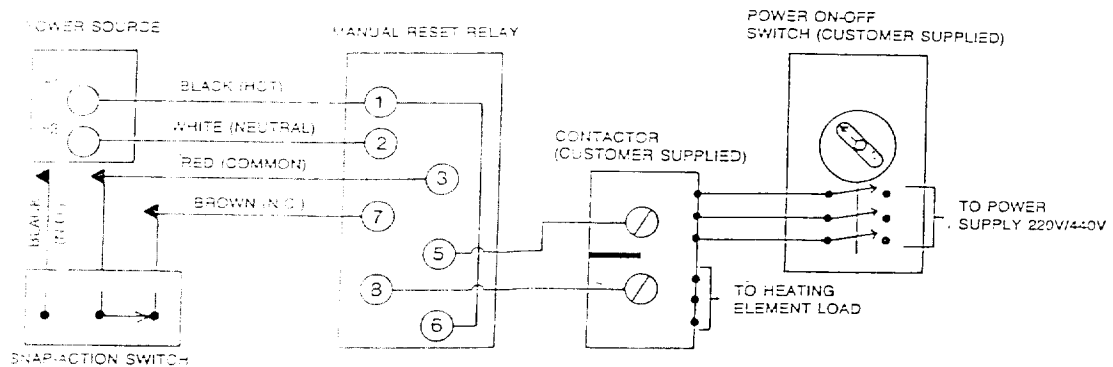

NOTE: DO NOT USE BLACK WIRE ON SNAP-ACTION SWITCH IN NORMAL INSTALLATION. BLACK WIRE TO BE USED ONLY FOR EXTRANEIOUS ALARM, LIGHT CIRCUITS, ETC.

WIRING SCHEMATIC

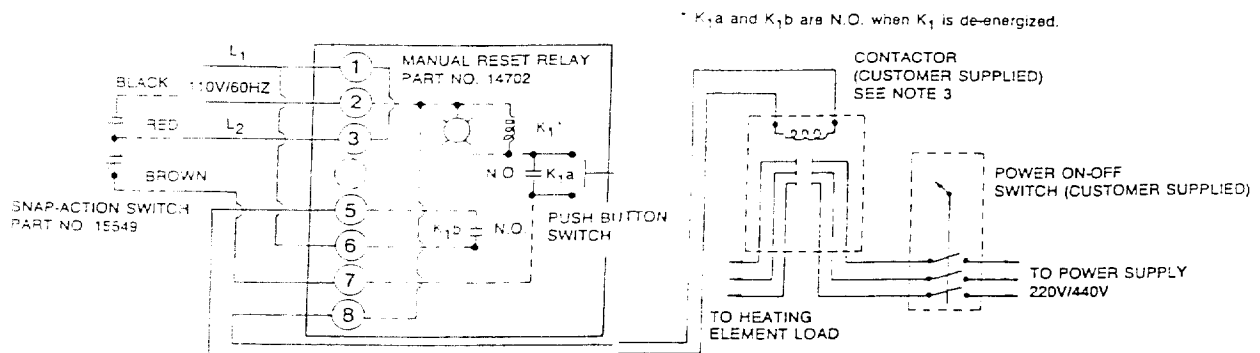

- NOTE:
- 1 - _____ DENOTES FIELD INSTALLATION.
 - 2 - _____ DENOTES FACTORY INSTALLATION.
 - 3 - CONTRACTORS: FULL LISTED ENCLOSED INDUSTRIAL CONTROL EQUIPMENT OR MAGNETIC SWITCH HAVING A RATING MATCHING THAT OF THE COOKING APPLIANCE COIL, 110V, 60HZ.

FIGURE 81

ELECTRICAL SWITCH REQUIREMENTS (Continued)
 Electric (110 VAC/60 Hz) Gas Shut-off Valve
 INSTALLATION OVERVIEW

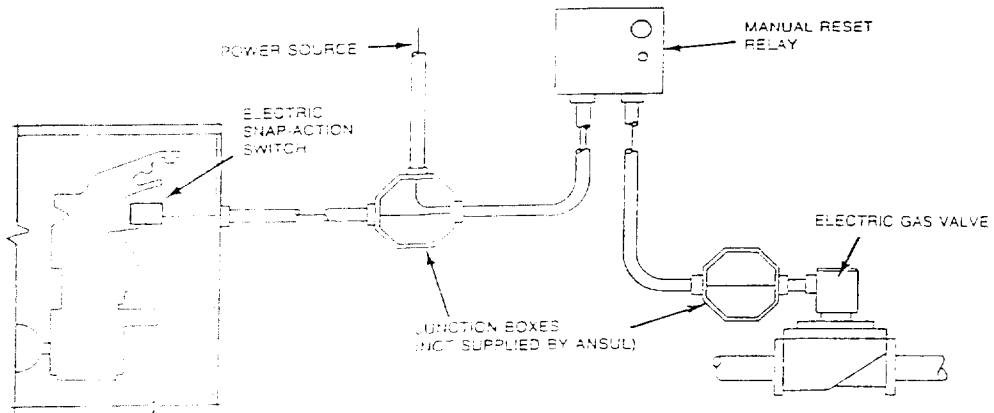

BASIC WIRING DIAGRAM

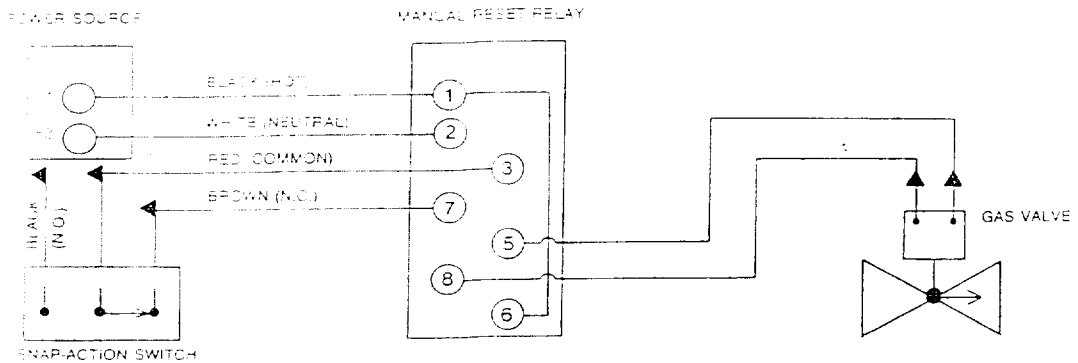

NOTE: DO NOT USE BLACK WIRE ON SNAP ACTION SWITCH IN NORMAL INSTALLATION. BLACK WIRE TO BE USED ONLY FOR EXTRANEIOUS ALARM, LIGHT CIRCUITS, ETC.

WIRING SCHEMATIC

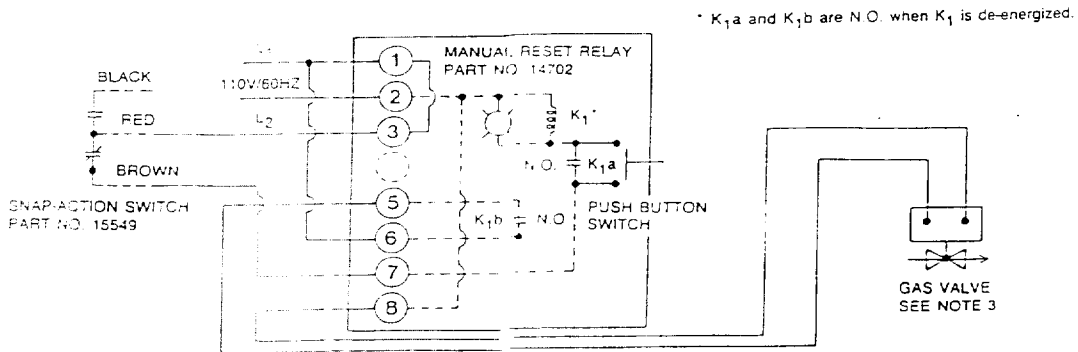

NOTE

- 1 ————— DENOTES FIELD INSTALLATION
- 2 - - - - - DENOTES FACTORY INSTALLATION
- 3 GAS VALVES: "UL LISTED ELECTRICALLY-OPERATED SAFETY VALVE FOR MANUAL OR LP GAS AS NEEDED OF APPROPRIATE PRESSURE AND TEMPERATURE RATING: 110V/60 HZ" OR ANSUL GAS VALVES. PART NUMBERS 13707, 13708, 13709, 13710, AND 13643.

FIGURE 80

FUSIBLE LINK

In order to determine the normal operating temperature at the fusible link location, utilize a maximum registering thermometer (Part No. 15240), temperature tape or other accurate thermometer.

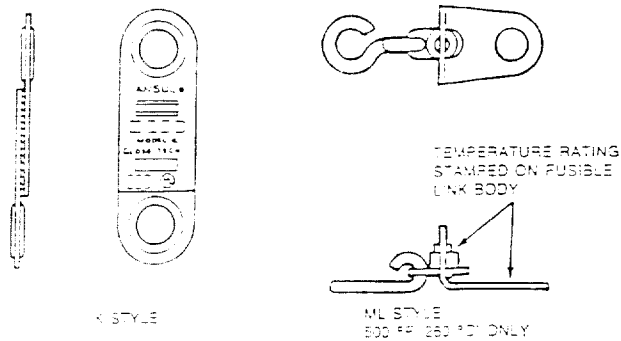

FIGURE 37

Select correct UL Listed fusible link(s) for installation in detector(s) according to the temperature condition chart below:

Fusible Link Part No.	Temperature Rating	To Be Used Where Temperature Does Not Exceed
415739	165 °F (74 °C)	100 °F (38 °C)
415740	212 °F (100 °C)	150 °F (66 °C)
415741	280 °F (138 °C)	225 °F (107 °C)
415742	350 °F (182 °C)	290 °F (143 °C)
415743	450 °F (232 °C)	360 °F (182 °C)
56316	500 °F (260 °C)	400 °F (204 °C)

BURSTING DISC

The R-102 Bursting Disc is installed in the tank adaptor assembly. The bursting disc eliminates the siphoning of the agent up the pipe during extreme temperature variations. The bursting discs are available in packs of 10, Part No. 417911.

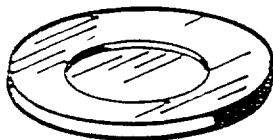

FIGURE 38

DETECTORS

The detector consists of three basic components: the bracket, linkage, and fusible link. (Fusible links are not included and must be ordered separately.) The bracket holds the entire assembly to the mounting surface. The linkage is used to support the fusible link. The fusible link is designed to separate at a specific temperature and release the wire rope, thereby actuating the regulated release mechanism.

There are three styles of detectors available: the clip-on style, the hinged style, and the scissor style.

The clip-on style allows the wire rope to be strung completely through the detection system conduit and brackets first and the detector linkage assemblies are then clipped on later.

The hinged style detector requires the wire rope to be strung to the detector bracket, and then "threaded" through the linkage assembly before continuing to the next detector bracket.

The scissor style allows the wire rope to be strung completely through the detection system conduit and brackets first and the detector linkage assemblies are then clipped on later.

Each style of detector consists of two types of assemblies:

The Terminal Detector (Part No. 56838, 15375, or 417368) includes a test link and is placed last in a series of detectors. This detector is sometimes referred to as the end-of-line detector and is thus named because it is at the point at which the wire rope "terminates," or is anchored at the detector bracket. Only one terminal detector is required per detection system.

The Series Detector (Part No. 56837, 15373, or 417369) is any detector located in-line between the regulated release assembly and the terminal detector.

When using Part No. 56837 and 56838 style detectors, a total of 12 detectors can be in one detection system: 11 series detectors, Part No. 56837 and 1 terminal detector, Part No. 56838.

When using Part No. 15373 and 15375 style detectors, a total of 8 detectors can be in one detection system: 4 series detectors, Part No. 15373 and 1 terminal detector, Part No. 15375.

When using Part No. 417368 and 417369 style detectors, a total of 16 detectors can be in one detection system: 14 series detectors, Part No. 417369 and 1 terminal detector, Part No. 417368.

CLIP-ON STYLE - PART NO. 56837 AND 56838

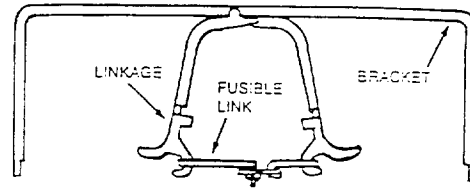

HINGED STYLE - PART NO. 15373 AND 15375

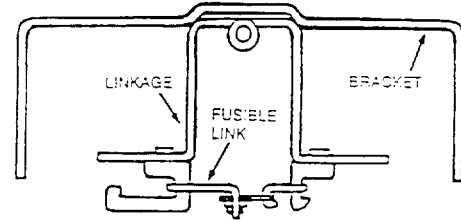

SCISSOR STYLE - PART NO. 417368 AND 417369

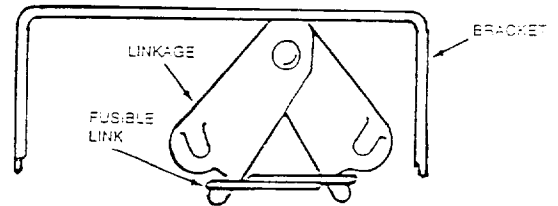

FIGURE 27

PULLEY ELBOWS

There are two types of pulley elbows used to change the direction of the wire rope by 90°. Ansul recommends for temperatures not in excess of 700 °F (371 °C). Part No. 415670 has socket ends with set screws for 1/2 in. conduit, and Part No. 45771 has compression ring ends also for 1/2 in. conduit.

PART NO. 415670

PART NO. 45771

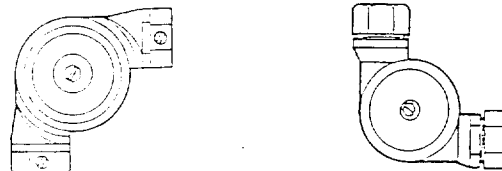

FIGURE 28

PULLEY TEE

The Pulley Tee (Part No. 15342) is used to change the direction of two wire ropes by 90°. It must be used in areas where the temperatures are within the range of 32 °F to 130 °F (0 °C to 54 °C). Pulley tees can be used in mechanical gas valve actuation lines and remote manual pull station lines. Pulley tees cannot be used within a detection line. Pulley tees can only be used to operate one gas valve from two ANSUL AUTOMAN Releases.

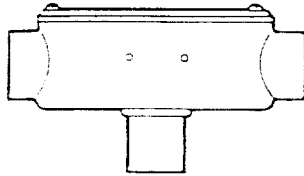

FIGURE 29

STAINLESS STEEL CABLE

The 1/16 in. stainless steel cable is run from the terminal detector, through conduit, all series detectors and pulley elbows, and into the regulated release mechanism trip lever. When any fusible link separates, the tension on the cable is relaxed, and the trip lever actuates the regulated release mechanism. The cable can also be used for mechanical gas valves and remote manual pull stations. The cable is available in 50 ft. (15 m) (Part No. 15821) and 500 ft. (152.4 m) (Part No. 79653) lengths.

REMOTE MANUAL PULL STATION

The remote manual pull station (Part No. 4835, Part No. 54011, or Part No. 415255) is required for manual actuation of the regulated release assembly. The remote manual pull station should be mounted at a point of egress and positioned at a height determined by the authority having jurisdiction.

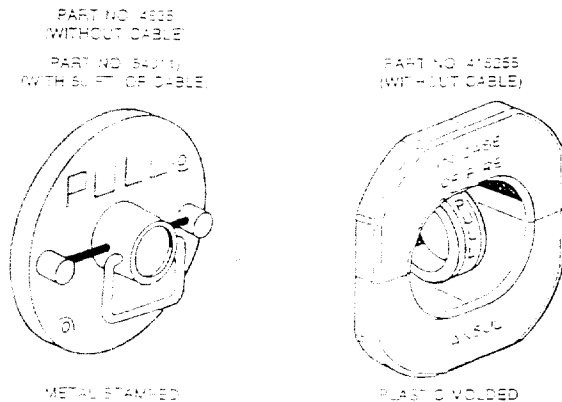

FIGURE 30

MECHANICAL GAS VALVES

The mechanical gas valves are designed to shut off the flow of gas to the appliances upon actuation of the regulated release assembly. The valves are available in sizes of 3/4 in., 1 in., 1 1/4 in., 1 1/2 in., and 2 in. Ansul style; and 2 1/2 in. and 3 in. Asco style. The valves are rated for natural and LP gas. Both styles are UL Listed.

Part No.	Description	Maximum Operating Pressure
55598	3/4 in. Gas Valve (ANSUL)	10 psi (69 kPa)
55601	1 in. Gas Valve (ANSUL)	10 psi (69 kPa)
55604	1 1/4 in. Gas Valve (ANSUL)	10 psi (69 kPa)
55607	1 1/2 in. Gas Valve (ANSUL)	10 psi (69 kPa)
55610	2 in. Gas Valve (ANSUL)	10 psi (69 kPa)
25937	2 1/2 in. Gas Valve (ASCO)	5 psi (34.5 kPa)
25938	3 in. Gas Valve (ASCO)	5 psi (34.5 kPa)

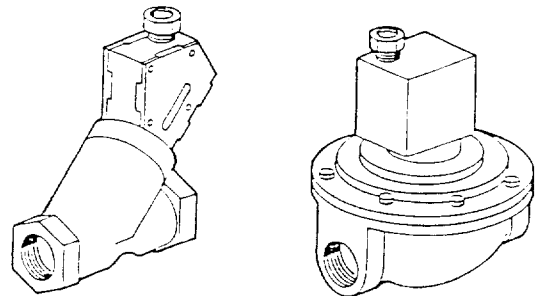

FIGURE 31

ELECTRICAL GAS VALVES

The electrical gas valves are designed to shut off the flow of either natural or LP gas to the appliances upon actuation of the regulated release assembly. The valves are available in sizes of 3/4 in., 1 in., 1 1/2 in., 2 in., and 3 in.. The valve is held open by an energized solenoid and upon system actuation, the switch contacts in the regulated release assembly open, thus de-energizing the circuit to the gas valve solenoid, causing the valve to close. Valves are available in 120 VAC and are UL Listed.

Part No.	Description	Maximum Operating Pressure
13707	3/4 in. Solenoid Gas Valve (ASCO)	2 psi (13.8 kPa)
13708	1 in. Solenoid Gas Valve (ASCO)	1 psi (6.9 kPa)
13709	1 1/2 in. Solenoid Gas Valve (ASCO)	25 psi (172 kPa)
13710	2 in. Solenoid Gas Valve (ASCO)	25 psi (172 kPa)
17643	3 in. Solenoid Gas Valve (ASCO)	5 psi (34.5 kPa)

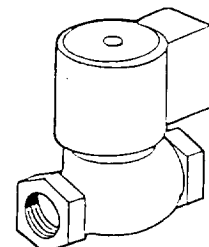

FIGURE 32

METAL BLOW-OFF CAP

Two types of metal blow-off caps are available as options to the standard rubber caps. The metal cap can be used in unusually high heat conditions, generally over 400° F (204° C). The metal blow-off cap is attached to the nozzle by means of a stainless steel wire which prevents it from falling into the appliance during discharge. Shipping Assembly Part No. 79745 contains 10 metal blow-off caps for use on standard, non-swivel nozzles and Shipping Assembly Part No. 415568 contains 10 metal blow-off caps for use on swivel nozzles.

NOTICE

If metal blow-off caps are required for upright broiler protection, use (2) two 1N nozzles (Part No. 56930) instead of 1/2N nozzles.

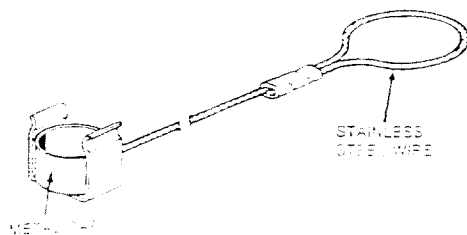

FIGURE 22

CONDUIT OFFSET ASSEMBLY

The conduit offset assembly, Part No. 79825, is used to change direction of the wire rope on detection, mechanical gas valve, and remote pull station lines. The conduit offset assembly can only be used in the area where the conduit attaches to the regulated release assembly. When using the conduit offset assembly, the maximum number of pulley elbows is still allowed.

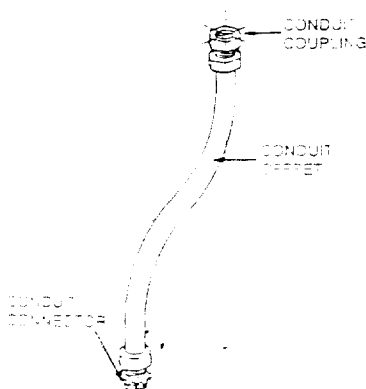

FIGURE 23

"QUIK-SEAL" ADAPTOR

The "Quik-Seal" adaptor is a listed mechanical bulkhead fitting that produces a liquid-tight seal around both distribution piping and detection conduit which runs through restaurant hoods and ducts. The "Quik-Seal" adaptor accepts threaded pipe or conduit. The adaptor is available for 1/4 in. (Part No. 78195), 3/8 in. (Part No. 77284), 1/2 in. (Part No. 77286), or 3/4 in. (Part No. 77288) pipe or conduit sizes. When using with EMT conduit, a conduit connector must be installed in each end of the adaptor.

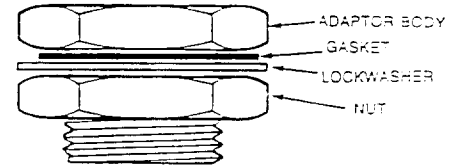

FIGURE 24

"COMPRESSION-SEAL" ADAPTOR

This adaptor is a mechanical bulkhead fitting that produces a liquid-tight seal around pipe and conduit when installing distribution piping and detection conduit through restaurant hoods and ducts. The "Compression-Seal" adaptor is a straight-through design requiring no cutting or threading of conduit or pipe. The adaptor is available for pipe sizes of 1/4 in. (Part No. 79148), 3/8 in. (Part No. 79150), 1/2 in. (Part No. 79146), and EMT conduit size of 1/2 in. (Part No. 79152).

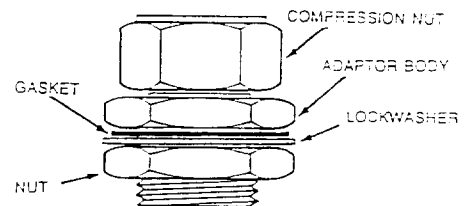

FIGURE 25

"HOOD SEAL" ADAPTOR ASSEMBLY

This adaptor, shipping assembly Part No. 79768, is a mechanical bulkhead fitting that produces a liquid-tight seal around 1/2 in. EMT conduit when installing the detection line through restaurant hoods and ducts. The adaptor accepts a high temperature pulley elbow and, when used, correctly positions the elbow or conduit in line with the conduit adaptor hole in the detector bracket. The "Hood Seal" eliminates the need for multiple elbows when penetrating the top of a hood when installing the detection line.

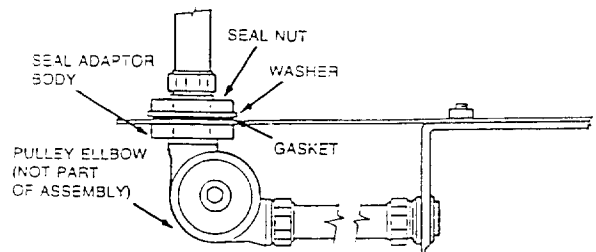

FIGURE 26

WARRANTY AND LIMITS OF WARRANTY

A. Ansul Products

Except as indicated in B below, your R-102 System, supplied by Ansul Incorporated ("Ansul") is warranted to you as the original purchaser for five years from the date of delivery against defects in workmanship and material as purchaser's sole and exclusive remedy. Ansul will replace or repair any component part which, in its opinion, is defective and has not been tampered with or subjected to misuse, abuse or exposed to highly corrosive conditions.

B. Purchased Products

The following items, which are not manufactured but purchased by Ansul, are warranted against defects resulting from the manufacturer's fabrication, process or parts for one year from the date of purchase: fusible links, electric gas shut-off valves, manual reset relay, snap-action switch and solenoid, detectors, electric manual pull station, pressure relief valves, and regulators.

Evaluation of each reportedly defective relay, valve, etc. returned to Ansul will be made by the original manufacturer or an agent thereof and its judgment shall be final.

EXCEPT AS PROVIDED IN (A) AND (B), THERE ARE NO OTHER WARRANTIES, EXPRESSED OR IMPLIED INCLUDING THE WARRANTIES OF MERCHANTABILITY AND FITNESS FOR PARTICULAR PURPOSE MADE BY ANSUL CONCERNING THIS SYSTEM. ANSUL SHALL HAVE NO LIABILITY FOR ANY CONSEQUENTIAL, SPECIAL OR SIMILAR DAMAGES.

For repairs, parts and service of the Ansul System, contact your local Ansul representative, or Ansul Incorporated, Marinette, Wisconsin 54143-2542; 800-TO-ANSUL, 800-862-8575.