

CITY OF SACRAMENTO

1231 I Street, Sacramento, CA 95814

Permit No: 0513583

Insp Area: 4

Thos Bros: 257C6

Site Address: 310 LYMAN CR SAC

Parcel No: 225-1290-054

Sub-Type: AOTHR

Housing (Y/N): N

CONTRACTOR
PETKUS BROS
3068 SUNRISE BL
RANCHO CORDOVA CA

OWNER
CHAN JASON/VALERIE
310 LYMAN CR
SACRAMENTO, CA 95835

ARCHITECT

Nature of Work: INSTALL NEW SOLID PATIO COVER WITH LATTICE ON THE EDGES - 284 SQ FT - (W/ ELE)

CONSTRUCTION LENDING AGENCY: I hereby affirm under penalty of perjury that there is a construction lending agency for the performance of the work for which this permit is issued (Sec. 3097, Civ. C).

Lender's Name _____ Lender's Address _____

LICENSED CONTRACTORS DECLARATION: I hereby affirm under penalty of perjury that I am licensed under provisions of Chapter 9 (commencing with section 7000) of Division 3 of the Business and Professions Code and my license is in full force and effect.

License Class B License Number 670242 Date 9/6/05 Contractor Signature Francisco Lopez

OWNER-BUILDER DECLARATION: I hereby affirm under penalty of perjury that I am exempt from the contractors License Law for the following reason (Sec. 7031.5, Business and Professions Code; any city or county which requires a permit to construct, alter, improve, demolish, or repair any structure, prior to its issuance, also requires the applicant for such permit to file a signed statement that he or she is licensed pursuant to the provisions of the Contractors License Law (Chapter 9 (commencing with Section 7000) of Division 8 of the Business and Professions Code) or that he or she is exempt therefrom and the basis for the alleged exemption. Any violation of Section 7031.5 by any applicant for a permit subjects the applicant to a civil penalty of not more than five hundred dollars (\$500.00);

_____, I, as a owner of the property, or my employees with wages as their sole compensation, will do the work, and the structure is not intended or offered for sale (Sec. 7044, Business and Professional Code: The Contractors License Law does not apply to an owner of property who builds or improves thereon, and who does such work himself or herself or through his/her own employees, provided that such improvements are not intended or offered for sale. If, however, the building or improvement is sold within one year of completion, the owner-builder will have the burden of proving that he/she did not build or improve for the purpose of sale.)

_____, I, as owner of the property, am exclusively contracting with licensed contractors to construct the project (Sec. 7044, Business and Professions Code: The Contractors License Law does not apply to an owner of property who builds or improves thereon, and who contracts for such projects with a contractor(s) licensed pursuant to the Contractors License Law).

I am exempt under Sec. _____ B & PC for this reason: _____
Date _____ Owner Signature _____

CITY OF SACRAMENTO
PAID
SEP 06 2005
NEIGHBORHOODS PLANNING AND DEVELOPMENT SERVICES

IN ISSUING THIS BUILDING PERMIT, the applicant represents, and the city relies on the representation of the applicant, that the applicant verified all measurements and locations shown on the application or accompanying drawings and that the improvement to be constructed does not violate any law or private agreement relating to permissible or prohibited locations for such improvements. This building permit does not authorize any illegal location of any improvement or the violation of any private agreement relating to location of improvements.

I certify that I have read this application and state that all information is correct. I agree to comply with all city and county ordinances and state laws relating to building construction and hereby authorize representative(s) of this city to enter upon the above mentioned property for inspection purposes.

Date 9/6/05 Applicant/Agent Signature Francisco Lopez

WORKER'S COMPENSATION DECLARATION: I hereby affirm under penalty of perjury one of the following declarations:

_____, I have and will maintain a certificate of consent to self-insure for workers' compensation as provided for by Section 3700 of the Labor Code, for the performance of work for which the permit is issued.

EP I have and will maintain workers' compensation insurance, as required by Section 3700 of the Labor Code, for the performance of the work for which this permit is issued. My workers' compensation insurance carrier and policy number are:

Carrier STATE FUND Policy Number 0000502-2004 Exp Date 10/01/2005

(This section need not be completed if the permit is for \$100 or less) I certify that in the performance of the work for which this permit is issued, I shall not employ any person in any manner so as to become subject to the workers' compensation laws of California and agree that if I should become subject to the workers' compensation provisions of Section 3700 of the Labor Code, I shall forthwith comply with those provisions.

Date 9/6/05 Applicant Signature Francisco Lopez

WARNING: FAILURE TO SECURE WORKER'S COMPENSATION COVERAGE IS UNLAWFUL AND SHALL SUBJECT AN EMPLOYER TO CRIMINAL PENALTIES AND CIVIL FINES UP TO ONE HUNDRED THOUSAND DOLLARS (\$100,000) IN ADDITION TO THE COST OF COMPENSATION, DAMAGES AS PROVIDED FOR IN SECTION 3706 OF THE LABOR CODE, INTEREST AND ATTORNEY'S FEE.

THIS PERMIT SHALL EXPIRE BY LIMITATION IF WORK IS NOT COMMENCED WITHIN 180 DAYS.

City of Sacramento
Development Services Department
PLANNING REVIEW FOR BUILDING PERMIT SUBMITTAL

ADDRESS: 310 LYMAN CIRCLE	APN: 225-1290-054
DRPB AREA / PUD / SPD: EXPANDED NORTH / NORTHPOINT PARK PUD	ZONING: R-1-PUD
EXISTING LAND USE: TWO STORY RSF WITH ATTACHED GARAGE	
PROPOSED USE: PATIO COVER ADDITION TO REAR OF EXISTING RSF	
PLANNING STAFF WILL CHECK ONE OR MORE OF THE ITEMS BELOW:	
<input type="checkbox"/>	Planning review is NOT required.
<input type="checkbox"/>	Use is NOT allowed; applicant CANNOT submit for plan check.
<input type="checkbox"/>	Requires APPLICATION(s): PC ZA IR ER DR PB Required Planning application must be approved <i>before</i> project can be submitted for plan check
<input type="checkbox"/>	Application(s) IN PROGRESS: File Number: Application must be approved <i>before</i> project can be submitted for plan check.
<input type="checkbox"/>	Application(s) COMPLETED: File Number & approval date: Building permit must conform to approved plans and comply with all conditions of approval. Do NOT accept applications for a building permit prior to the end of the 10-day appeal period.
<input checked="" type="checkbox"/>	Plans may be submitted for plan check. Plan checker(s) shall confirm compliance with Zoning Ordinance requirements and all applicable development standards <i>prior to issuance</i> of building permit.
<input checked="" type="checkbox"/>	Meets setback & lot coverage requirements as shown on site plan provided.
<input checked="" type="checkbox"/>	Plans to be submitted have been stamped/signed by Planning counter staff.
<input type="checkbox"/>	Route to SITE for plan check and inspection.
<input type="checkbox"/>	Route to SITE for inspection only, plan check not required.
<input type="checkbox"/>	Preliminary review ONLY; the information on this form must be reviewed again and confirmed at the time of building permit submittal.
CONDITIONS AND COMMENTS: LOT AREA = 6825 (METORSCAN). EXISTING FOOTPRINT = 2314 + 284 = 2598 / 6825 = 38% TOTAL LOT COVERAGE. MEETS ALL SETBACK AND LOT COVERAGE REQUIREMENTS. MEETS ALL SETBACK AND LOT COVERAGE REQUIREMENTS. NO ADDITIONAL PLANNING ENTITLEMENTS APPARENT. NO DESIGN REVIEW APPROVAL REQUIRED, NOT VISIBLE FROM STREET VIEW.	
DATE: 09/06/05	BY: BONNIE SURGEON

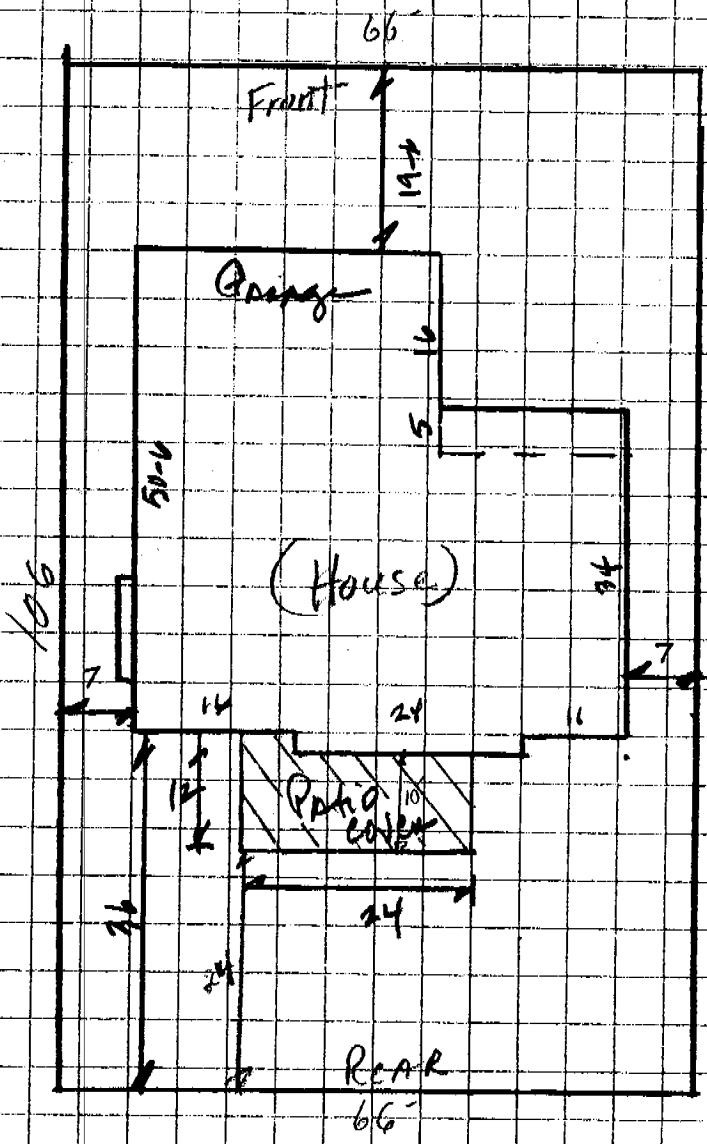

Valerie Chan
 310 Lyman Circle
 Sacramento 95835

419-5206

ISSUED
 City of Sacramento

AUG 25 2005
 NORTH PERMIT
 CENTER

APPROVED SETBACKS & LOT COVERAGE
 DATE: 9/6/05 BY: [Signature]
 CITY OF SACRAMENTO - PLANNING DIVISION
 THIS APPROVAL SHALL NOT BE HELD TO PERMIT OR
 APPROVE THE VIOLATION OF ANY STATE LAW, CITY
 ORDINANCE, OR PRIVATE AGREEMENT, AND ASSUMES
 THAT PROPERTY LINES AND OTHER INFORMATION
 SUBMITTED BY THE APPLICANT ARE ACCURATE AND
 COMPLETE.

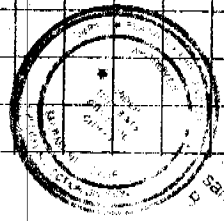

This set of plans and specifications must be
 submitted on the day of filing and is unlawful
 to alter or amend from the
 original submission from the
 Planning Division. Approval of this plan and specification
 shall not be held to permit or approve the
 violation of any City Ordinance or State Law.

CITY COPY

0513583

310

LYMAN CIR

LAYOUT GRID

FRONT

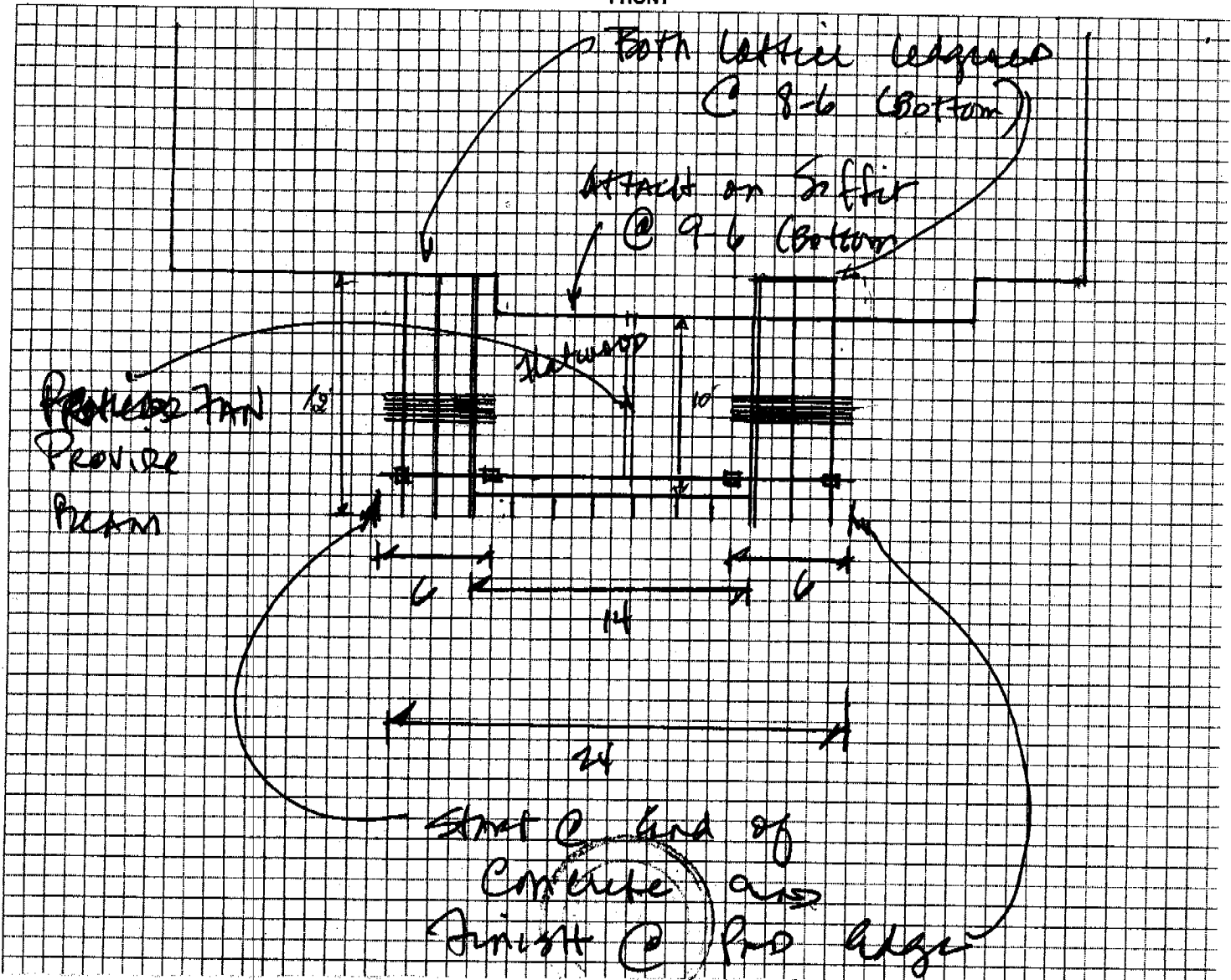

This set of plans and specifications must be read in conjunction with the City of Sacramento Building Code, which is hereby incorporated by reference into these plans. The contractor shall be responsible for obtaining all necessary permits and for the satisfaction of any City Ordinance or State Law.

ISSUED
 City of Sacramento
 AUG 25 2005
 NORTH PERMITS
 CENTER



ICC Evaluation Service, Inc.
www.icc-es.org

Business/Regional Office ■ 5360 Workman Mill Road, Whittier, California 90601 ■ (562) 699-0543
Regional Office ■ 900 Montclair Road, Suite A, Birmingham, Alabama 35213 ■ (205) 599-9800
Regional Office ■ 4051 West Flossmoor Road, Country Club Hills, Illinois 60478 ■ (708) 799-2305

Legacy report on the 1997 Uniform Building Code™

DIVISION: 10—SPECIALTIES
Section: 10530—Protective Covers

ATTACHED AND FREESTANDING PATIO COVERS AND COMMERCIAL ROOF STRUCTURES

AMERIMAX BUILDING PRODUCTS, INC.
5208 TENNYSON PARKWAY, SUITE 100
PLANO, TEXAS 75024

*Retain Previous Plans

1.0 SUBJECT

Attached and Freestanding Patio Covers and Commercial Roof Structures.

2.0 DESCRIPTION

2.1 General:

The patio covers and commercial roof structures include freestanding and attached designs. The walls must be unenclosed. Allowable loads and a summary of plans under this report are shown in Table 1.

2.2 Materials:

2.2.1 Aluminum: The aluminum is available in roll-formed and extruded shapes of various alloys and tempers, complying with Chapter 20 of the UBC.

2.2.2 Steel: The steel is various grades of galvanized, cold-formed steel complying with ASTM A 653.

2.3 Installation:

The structures are erected and framed in the manner set forth in the attached plans.

2.4 Identification:

Each structure bears a permanent decal or identifying tag stating the allowable roof live load, the horizontal wind load, the uplift wind load, the name of the manufacturer and the model number.

3.0 EVIDENCE SUBMITTED

Plans, calculations, and reports of transverse load tests and fastener tests.

4.0 FINDINGS

That the Attached and Freestanding Patio Covers and Commercial Roof Structures of Amerimax Building Products, Inc., described in this report comply with the 1997 Uniform Building Code™ (UBC), subject to the following conditions:

4.1 Construction is in accordance with the attached plans, dated February 8, 2000, and the UBC, except the maximum snow loads are limited to 30 psf.

4.2 The 10 psf (479 Pa) live load patio covers are in compliance with Appendix Chapter 31, Division III, of the UBC.

This report is subject to re-examination in one year.

Table 1: Summary of Design Loads. Columns include Drawing Number, No. of Pages, Type of Structure, Support Method, Design Load (psf) [Roof Live, Horizontal Wind, Wind Uplift], and Permitted Enclosure. Rows include 97GN (General notes), 97SC (Structural configurations), 97CD (Component parts and details), and 97LT (Component parts and details).

For SI: 1 psf = 47.88 Pa, 1 mph = 1.61 km/h.

Horizontal wind and wind-uplift loads developed with a basic wind speed of 70 or 90 mph, Exposures B and C, in accordance with Chapter 16, Division III, of the UBC. Patio-cover horizontal wind and wind-uplift loads developed with a 70 or 90 mph basic wind speed, in accordance with Appendix Chapter 31, Division III, of the UBC.

ICC-ES legacy reports are not to be construed as representing aesthetics or any other attributes not specifically addressed, nor are they to be construed as an endorsement of the subject of the report or a recommendation for its use. There is no warranty by ICC Evaluation Service, Inc., express or implied, as to any finding or other matter in this report, or as to any product covered by the report.



DRAWING	PAGES
97GN01	2 PAGES
97GN02	2 PAGES
97SC01	2 PAGES
97SC02	2 PAGES
97LT01	1 PAGE
97LT02	1 PAGE
97LT03	1 PAGE
97LT04	1 PAGE
97CD01	1 PAGE
97CD02	1 PAGE
97CD03	1 PAGE
97CD04	1 PAGE
97CD05	1 PAGE
97CD06	1 PAGE
97CD07	1 PAGE
97CD08	1 PAGE
97CD09	1 PAGE

ECBO ES EVALUATION REPORT NO ER-2621P

TABLE OF CONTENTS









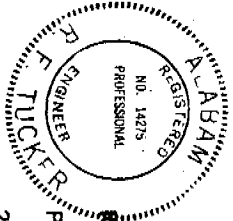
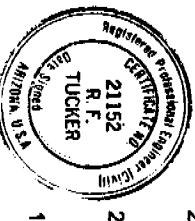
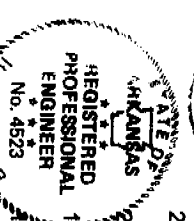
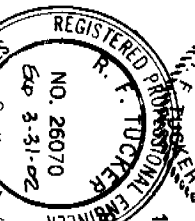
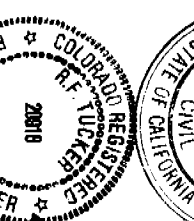

GENERAL NOTES

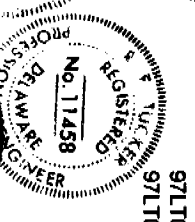
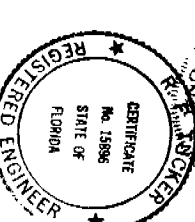
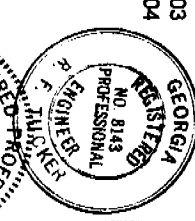
STRUCTURAL CONFIGURATIONS

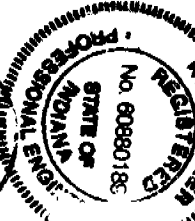
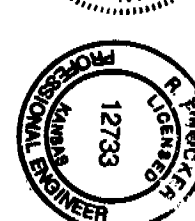
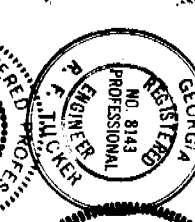
- 1.0 ROOF PANEL SPANS AND OVERHANGS
- 2.0 FREESTANDING AND ATTACHED PATIO STRUCTURES
- 3.0 FREESTANDING AND ATTACHED COMMERCIAL STRUCTURES
- 4.0 FREESTANDING AND ATTACHED LATTICE PATIO STRUCTURES
- 5.0 FREESTANDING AND ATTACHED LATTICE COMMERCIAL STRUCTURES
- 6.0 COLUMN AND FASTENER REQUIREMENTS FOR COMMERCIAL AND PATIO STRUCTURES

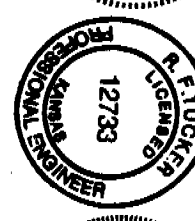
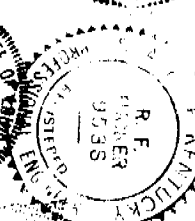
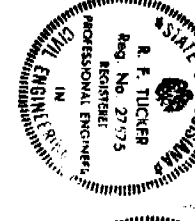
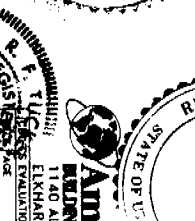
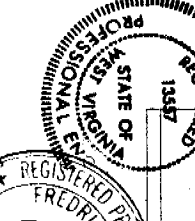
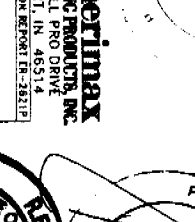
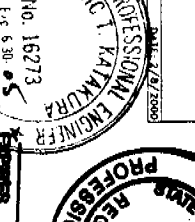
COMPONENT PARTS AND CONNECTION DETAILS

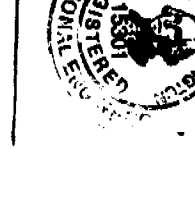
COMPONENT PARTS AND CONNECTION DETAILS FOR PATIO AND COMMERCIAL LATTICE STRUCTURE

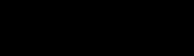
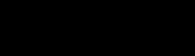
I hereby certify that this plan, specification, or report was prepared by me or under my direct supervision and that I am a duly Registered Professional Engineer under the laws of the State of Minnesota.

R. F. TUCKER
 Registered No. 22
 PROFESSIONAL ENGINEER

Amcitemax
 BUILDING PRODUCTS, INC.
 1140 ALL PRO DRIVE
 ELKHART, IN 46514
 TEL: 219-291-2000
 FAX: 219-291-2000

APR 18 2003

GENERAL NOTES:
(CONTINUED FROM SHEET NO. 1)

- NOTE: EXPOSURE "B" HAS TERRAIN WHICH HAS BUILDINGS, FOREST OR SURFACE IRREGULARITIES COVERING AT LEAST 20 PERCENT OF THE GROUND LEVEL AREA EXTENDING ONE MILE OR MORE FROM THE SITE.
EXPOSURE "C" HAS TERRAIN WHICH IS FLAT AND GENERALLY OPEN, EXTENDING ONE-HALF MILE OR MORE FROM THE SITE, IN ANY FULL QUADRANT.
- CONCRETE MIX: $f_c=2500$ PSI 28 DAYS, APPENDIX CHAPTER 31 DIVISION III PATIO STRUCTURES MAY BE ATTACHED TO CONCRETE SLAB WITHOUT FOOTINGS WHEN THE COLUMN LOAD IS 750# OR LESS. CONCRETE SHALL BE A MINIMUM OF 3.5 INCHES THICK AND NO CRACKS WITHIN 2-6" OF COLUMNS. COLUMNS SHALL BE SET BACK A MINIMUM OF 4 INCHES FROM EDGE OF SLAB.
 - FOOTINGS HAVE BEEN DESIGNED FOR CLASS 5 SOIL. ALLOWABLE SOIL BEARING PRESSURE OF 1000 POUNDS PER SQUARE FOOT. STRUCTURES SUPPORTED BY FLAGPOLE TYPE COLUMNS ARE NOT ADVERSELY AFFECTED BY A 1/2 INCH LATERAL GROUND MOVEMENT AND FOOTINGS FOR THOSE STRUCTURES HAVE BEEN DESIGNED FOR AN ALLOWABLE LATERAL SOIL BEARING PRESSURE OF 200 POUNDS PER SQUARE FOOT PER FOOT OF DEPTH. SOILS OF ORGANIC CLAYS OR SILTS REQUIRE A SOIL INVESTIGATION AND SPECIALLY DESIGNED FOOTINGS. FILLS MUST BE PLACED UNDER A LABORATORY CONTROLLED COMPACTION SUBJECT TO APPROVAL OF THE BUILDING OFFICIAL.
 - ALUMINUM BOLTS TO BE 2024-T4.
 - COMMERCIAL STRUCTURES MAY BE USED FOR PARKING OF MOTOR VEHICLES PER LOCAL BUILDING CODES. APPENDIX CHAPTER 31 DIVISION III PATIO STRUCTURES MAY NOT BE USED FOR PARKING OF MOTOR VEHICLES.
 - FREESTANDING STRUCTURES SHALL NOT BE ENCLOSED IN ANY MANNER.
 - STEEL BOLTS SHALL BE ASTM A-307.
 - ALTERNATE ALUMINUM ALLOYS OF EQUAL OR HIGHER STRENGTHS MAY BE USED.
 - STEEL FASTENERS SHALL BE EITHER STAINLESS, GALVANIZED OR DOUBLE CADMIUM PLATED "AN" BOLTS.
 - HIGH STRENGTH BOLTS SHALL BE ASTM A-325.
 - EMBEDDED COLUMN SURFACES SHALL BE CLEAN AND FREE FROM OILY SURFACES.
 - PATIO STRUCTURES ARE DESIGNED IN ACCORDANCE WITH APPENDIX CHAPTER 31 DIVISION III OF THE UNIFORM BUILDING CODE.
 - HEADER SPLICES SHALL NOT BE LOCATED NEARER TO THE END OF THE STRUCTURE THAN THE FIRST INTERIOR COLUMN.

- PATIO STRUCTURES MAY BE ENCLOSED WITH INSECT SCREENING.
- STRUCTURES MAY BE ATTACHED TO RAFTER OVERHANGS PER SCHEDULE.
- WHERE ALUMINUM ALLOY PARTS ARE IN CONTACT WITH DISSIMILAR METALS OTHER THAN STAINLESS, ALUMINIZED OR GALVANIZED STEEL, OR ABSORBENT BUILDING MATERIALS, LIKELY TO BE CONTINUOUSLY OR INTERMITTENTLY WET, THE FACING SURFACES SHALL BE PAINTED OR OTHERWISE SEPARATED IN ACCORDANCE WITH U.B.C. SECTION 2004.3.
- ALL SCREWS CONFORM TO ANSI B18-6-4 AND SAE J933.

GENERAL NOTES FOR LATTICE STRUCTURES: specifications must be (PERTAINS TO PATIO STRUCTURES ON DRAWINGS: 97SG02 AND 97LT01 (HPU 97LT06.)

- SEE GENERAL NOTES, SHEET 1, SECTION 4 FOR WIND LOAD AND WIND LOADS.
- OPEN LATTICE STRUCTURES SHALL NOT BE ENCLOSED.

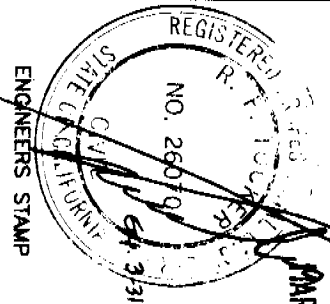

REGISTERED PROFESSIONAL ENGINEER
R. P. ...
NO. 26079
STATE OF CALIFORNIA
EXPIRES 3/31/02



REGISTERED PROFESSIONAL ENGINEER
...
NO. 10273
STATE OF CALIFORNIA
EXPIRES 1/1/00

DATE	REVISION	DATE	REVISION
MAR 09 2000			



Ametimax
Engineering Services
1140 All Pro Drive
Edmond, OK 73034

ICBO ES EVALUATION REPORT NO. ER-2621P

DRAWN BY: KG	DRAWING TITLE: GENERAL NOTES	SCALE: NONE	SHEET: 2 OF 2
DATE: 2/8/2000	REVISION: 97GN02		

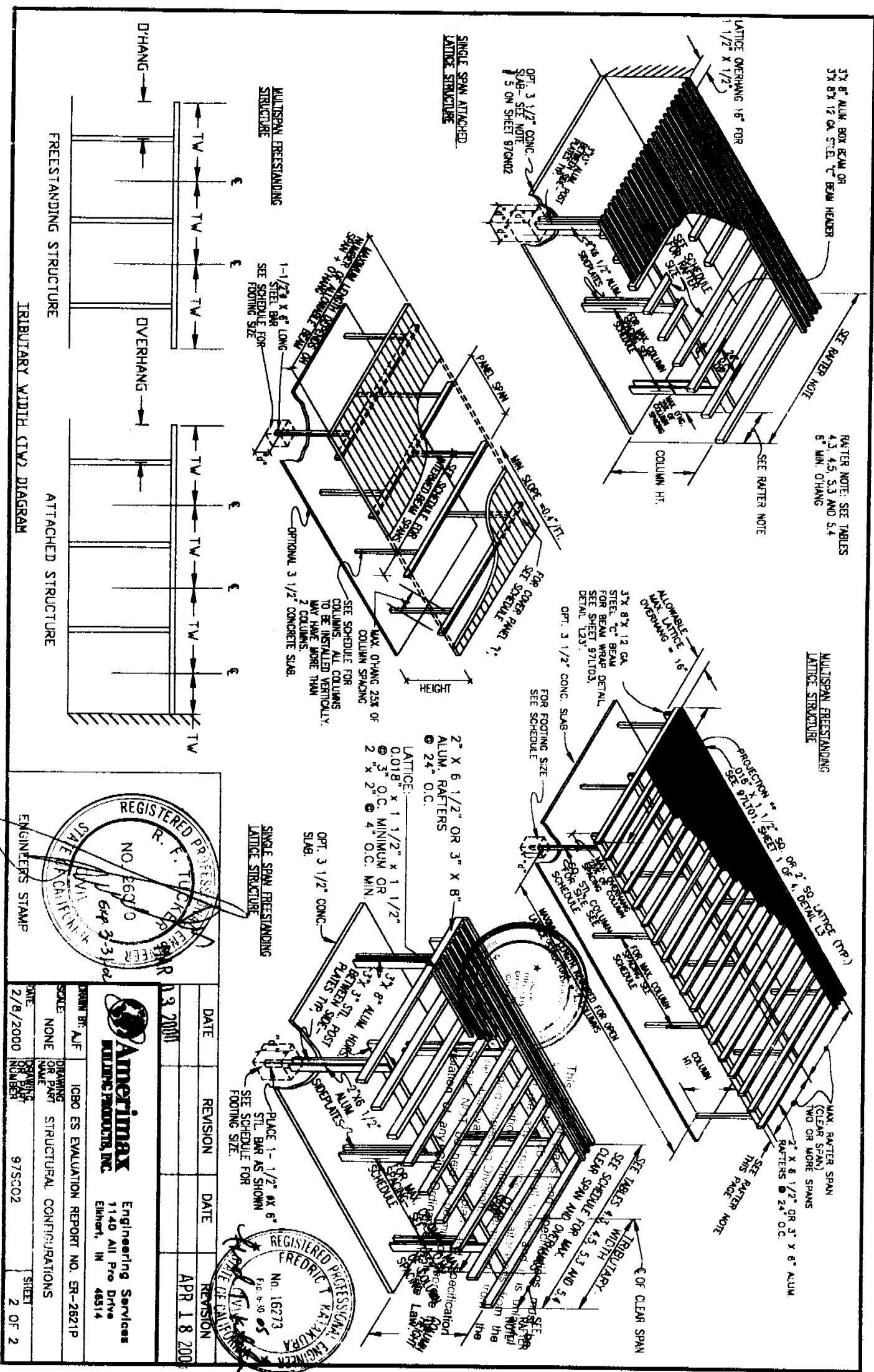

3" x 8" ALUM. BOX BEAM OR 3" x 8" x 12 GA. STEEL "C" BEAM HEADER
 Rafter Note: SEE TABLES 4.3, 4.5, 5.3 AND 5.4
 6" MIN. OVERHANG

MULTISPAN FREESTANDING LATTICE STRUCTURE

MAX. RAFTER SPAN (CLEAR SPAN) TWO OR MORE SPANS
 2" x 8 1/2" OR 3" x 8" ALUM. RAFTERS @ 24" O.C.
 SEE RAFTER NOTE

3" x 8" x 12 GA. STEEL "C" BEAM FOR BEAM WRAP DETAIL SEE SHEET 971103, DETAIL 123'
 OPT. 3 1/2" CONC. SLAB FOR FOOTING SIZE SEE SCHEDULE

2" x 6 1/2" OR 3" x 8" ALUM. RAFTERS @ 24" O.C.
 LATTICE: 1-1/2" x 1-1/2" @ 0.018" MINIMUM OR 3" O.C. MINIMUM OR 2" x 2" @ 4" O.C. MIN.

SINGLE SPAN FREESTANDING LATTICE STRUCTURE

PLACE 1-1/2" x 8" STL. BAR AS SHOWN SEE SCHEDULE FOR FOOTING SIZE

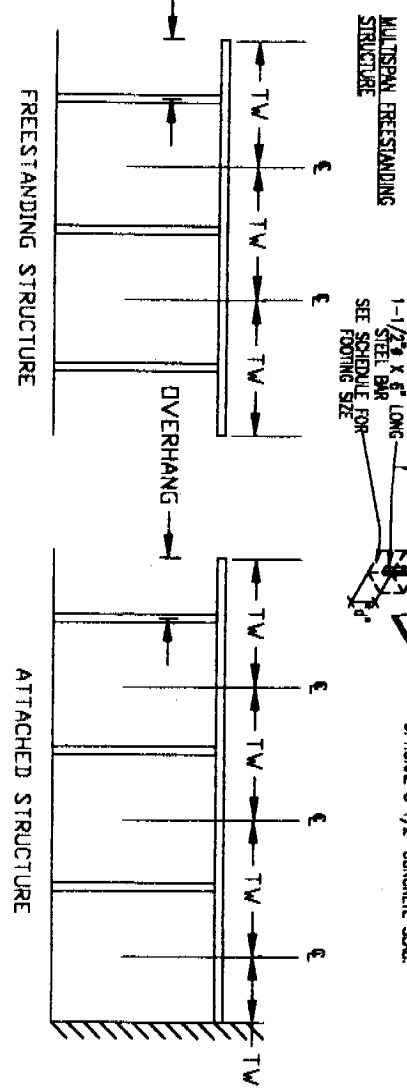

FREESTANDING STRUCTURE
 ATTACHED STRUCTURE
 TRIBUTARY WIDTH (T/W) DIAGRAM

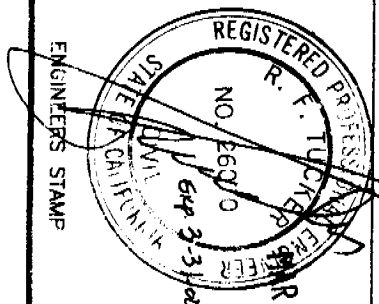

DATE	REVISION	DATE	REVISION
03/2000		APR 18 2000	

DRAWN BY: AJF
 SCALE: NONE
 DATE: 2/8/2000
 DRAWING OR PART NAME: STRUCTURAL CONFIGURATIONS
 DRAWING OR PART NUMBER: 97SC02
 SHEET: 2 OF 2

Amerimax
 BUILDING PRODUCTS, INC.
 Engineering Services
 1140 All Pro Drive
 Elkhart, IN 46514

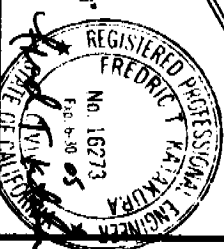

1.0 ROOF PANEL SPANS AND OVERHANGS FOR PATIO AND COMMERCIAL STRUCTURES

3 1/2" x 12" ROOF PANEL DESIGN SPAN FOR PATIO STRUCTURES				2 1/2" x 6" ROOF PANEL DESIGN SPAN FOR PATIO STRUCTURES			
LIVE LOAD (PSF)	PANEL T	70 MPH WIND	90 MPH WIND	LIVE LOAD (PSF)	PANEL T	70 MPH WIND	90 MPH WIND
10	0.018	16'-7"	18'-2"	10	0.018	13'-5"	13'-5"
20	0.024	18'-4"	18'-4"	20	0.024	14'-4"	14'-4"
30	0.032	20'-4"	20'-4"	30	0.032	15'-11"	15'-11"
40	0.038	21'-4"	21'-4"	40	0.038	16'-11"	16'-11"
50	0.044	21'-4"	21'-4"	50	0.044	16'-11"	16'-11"
60	0.048	21'-4"	21'-4"	60	0.048	16'-11"	16'-11"

3 1/2" x 12" ROOF PANEL ALLOW. DESIGN SPAN FOR COMMERCIAL STRUCTURES				2 1/2" x 6" ROOF PANEL ALLOW. DESIGN SPAN FOR COMMERCIAL STRUCTURES			
LIVE LOAD (PSF)	PANEL T	70 MPH WIND	90 MPH WIND	LIVE LOAD (PSF)	PANEL T	70 MPH WIND	90 MPH WIND
10	0.018	13'-5"	13'-5"	10	0.018	10'-5"	10'-5"
20	0.024	14'-4"	14'-4"	20	0.024	11'-4"	11'-4"
30	0.032	15'-11"	15'-11"	30	0.032	12'-7"	12'-7"
40	0.038	16'-11"	16'-11"	40	0.038	13'-4"	13'-4"
50	0.044	16'-11"	16'-11"	50	0.044	13'-4"	13'-4"
60	0.048	16'-11"	16'-11"	60	0.048	13'-4"	13'-4"

2 1/2" x 12" ROOF PANEL ALLOW. SPAN FOR COMMERCIAL STRUCTURES				2 1/2" x 12" ROOF PANEL ALLOW. SPAN FOR COMMERCIAL STRUCTURES			
LIVE LOAD (PSF)	PANEL T	70 MPH WIND	90 MPH WIND	LIVE LOAD (PSF)	PANEL T	70 MPH WIND	90 MPH WIND
10	0.018	12'-1"	12'-1"	10	0.018	10'-11"	10'-11"
20	0.024	12'-1"	12'-1"	20	0.024	11'-11"	11'-11"
30	0.032	13'-1"	13'-1"	30	0.032	12'-11"	12'-11"
40	0.038	14'-1"	14'-1"	40	0.038	13'-11"	13'-11"
50	0.044	14'-1"	14'-1"	50	0.044	13'-11"	13'-11"
60	0.048	14'-1"	14'-1"	60	0.048	13'-11"	13'-11"

2 1/2" x 12" ROOF PANEL ALLOW. SPAN FOR COMMERCIAL STRUCTURES				2 1/2" x 12" ROOF PANEL ALLOW. SPAN FOR COMMERCIAL STRUCTURES			
LIVE LOAD (PSF)	PANEL T	70 MPH WIND	90 MPH WIND	LIVE LOAD (PSF)	PANEL T	70 MPH WIND	90 MPH WIND
10	0.018	11'-11"	11'-11"	10	0.018	10'-11"	10'-11"
20	0.024	12'-2"	12'-2"	20	0.024	11'-2"	11'-2"
30	0.032	13'-2"	13'-2"	30	0.032	12'-2"	12'-2"
40	0.038	14'-2"	14'-2"	40	0.038	13'-2"	13'-2"
50	0.044	14'-2"	14'-2"	50	0.044	13'-2"	13'-2"
60	0.048	14'-2"	14'-2"	60	0.048	13'-2"	13'-2"

PANEL TO PANEL FASTENING			
PANEL T	PATIO EXP. B	EXPOSURE C	MAX OVERHANG
0.018	8"	5"	4'-5"
0.024	11"	5'-6"	5'-11"
0.032	14"	6'-8"	6'-8"
0.038	14"	6'-8"	6'-8"
0.044	14"	6'-8"	6'-8"
0.048	14"	6'-8"	6'-8"

2 1/2" x 12" ROOF PANEL DESIGN SPAN FOR PATIO STRUCTURES			
LIVE LOAD (PSF)	PANEL T	70 MPH WIND	90 MPH WIND
10	0.018	16'-7"	18'-2"
20	0.024	18'-4"	18'-4"
30	0.032	20'-4"	20'-4"
40	0.038	21'-4"	21'-4"
50	0.044	21'-4"	21'-4"
60	0.048	21'-4"	21'-4"

2 1/2" x 12" ROOF PANEL DESIGN SPAN FOR PATIO STRUCTURES			
LIVE LOAD (PSF)	PANEL T	70 MPH WIND	90 MPH WIND
10	0.018	13'-5"	13'-5"
20	0.024	14'-4"	14'-4"
30	0.032	15'-11"	15'-11"
40	0.038	16'-11"	16'-11"
50	0.044	16'-11"	16'-11"
60	0.048	16'-11"	16'-11"

2 1/2" x 12" ROOF PANEL ALLOW. DESIGN SPAN FOR COMMERCIAL STRUCTURES			
LIVE LOAD (PSF)	PANEL T	70 MPH WIND	90 MPH WIND
10	0.018	10'-5"	10'-5"
20	0.024	11'-4"	11'-4"
30	0.032	12'-7"	12'-7"
40	0.038	13'-4"	13'-4"
50	0.044	13'-4"	13'-4"
60	0.048	13'-4"	13'-4"

2 1/2" x 12" ROOF PANEL ALLOW. DESIGN SPAN FOR COMMERCIAL STRUCTURES			
LIVE LOAD (PSF)	PANEL T	70 MPH WIND	90 MPH WIND
10	0.018	12'-1"	12'-1"
20	0.024	12'-1"	12'-1"
30	0.032	13'-1"	13'-1"
40	0.038	14'-1"	14'-1"
50	0.044	14'-1"	14'-1"
60	0.048	14'-1"	14'-1"

2 1/2" x 12" ROOF PANEL ALLOW. DESIGN SPAN FOR COMMERCIAL STRUCTURES			
LIVE LOAD (PSF)	PANEL T	70 MPH WIND	90 MPH WIND
10	0.018	11'-11"	11'-11"
20	0.024	12'-2"	12'-2"
30	0.032	13'-2"	13'-2"
40	0.038	14'-2"	14'-2"
50	0.044	14'-2"	14'-2"
60	0.048	14'-2"	14'-2"

2 1/2" x 12" ROOF PANEL ALLOW. DESIGN SPAN FOR COMMERCIAL STRUCTURES			
LIVE LOAD (PSF)	PANEL T	70 MPH WIND	90 MPH WIND
10	0.018	10'-11"	10'-11"
20	0.024	11'-11"	11'-11"
30	0.032	12'-11"	12'-11"
40	0.038	13'-11"	13'-11"
50	0.044	13'-11"	13'-11"
60	0.048	13'-11"	13'-11"

2 1/2" x 12" ROOF PANEL ALLOW. DESIGN SPAN FOR COMMERCIAL STRUCTURES			
LIVE LOAD (PSF)	PANEL T	70 MPH WIND	90 MPH WIND
10	0.018	12'-1"	12'-1"
20	0.024	12'-1"	12'-1"
30	0.032	13'-1"	13'-1"
40	0.038	14'-1"	14'-1"
50	0.044	14'-1"	14'-1"
60	0.048	14'-1"	14'-1"

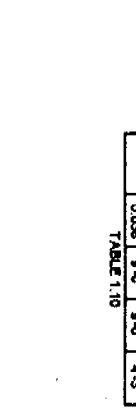

REGISTERED PROFESSIONAL ENGINEER
 NO. 26078
 STATE OF CALIFORNIA
 CIVIL ENGINEER
 APR 18 2009
 Specifications must be approved by the City Ordinance or State Law.

Amerimax
 BUILDING PRODUCTS, INC.
 1140 ALL PRO DRIVE
 ELKHART, IN 46514
 ICB0 ES EVALUATION REPORT ER-2621F
 ROOF PANEL SPANS FOR PATIO AND COMMERCIAL STRUCTURES
 PANEL SPANS FOR ALL 2.5" PAN FOR PATIO AND COMMERCIAL STRUCTURES
 SHEET 1 OF 8

3.0 PRESTRESSING AND ATTACHED COMMERCIAL STRUCTURES

LINE	TRIB	LOAD	4" BEAM				7" BEAM				12" BEAM							
			MAX. COLUMN SPACING	CONC. FOOTER SIZE	AIR SPACING	MAX. COLUMN SPACING	CONC. FOOTER SIZE	AIR SPACING	MAX. COLUMN SPACING	CONC. FOOTER SIZE	AIR SPACING	MAX. COLUMN SPACING	CONC. FOOTER SIZE	AIR SPACING				
25	4	10-0"	33	36	39	40	24	24	24	24	34	36	39	41	29	30	31	31
5	5	10-0"	33	36	39	40	24	24	24	24	34	36	39	41	29	30	31	31
6	6	10-0"	33	36	39	40	24	24	24	24	34	36	39	41	29	30	31	31
7	7	10-0"	33	36	39	40	24	24	24	24	34	36	39	41	29	30	31	31
8	8	10-0"	33	36	39	40	24	24	24	24	34	36	39	41	29	30	31	31
9	9	10-0"	33	36	39	40	24	24	24	24	34	36	39	41	29	30	31	31
10	10	10-0"	33	36	39	40	24	24	24	24	34	36	39	41	29	30	31	31
11	11	10-0"	33	36	39	40	24	24	24	24	34	36	39	41	29	30	31	31
12	12	10-0"	33	36	39	40	24	24	24	24	34	36	39	41	29	30	31	31
13	13	10-0"	33	36	39	40	24	24	24	24	34	36	39	41	29	30	31	31
14	14	10-0"	33	36	39	40	24	24	24	24	34	36	39	41	29	30	31	31
15	15	10-0"	33	36	39	40	24	24	24	24	34	36	39	41	29	30	31	31
16	16	10-0"	33	36	39	40	24	24	24	24	34	36	39	41	29	30	31	31
17	17	10-0"	33	36	39	40	24	24	24	24	34	36	39	41	29	30	31	31
18	18	10-0"	33	36	39	40	24	24	24	24	34	36	39	41	29	30	31	31
19	19	10-0"	33	36	39	40	24	24	24	24	34	36	39	41	29	30	31	31
20	20	10-0"	33	36	39	40	24	24	24	24	34	36	39	41	29	30	31	31
21	21	10-0"	33	36	39	40	24	24	24	24	34	36	39	41	29	30	31	31
22	22	10-0"	33	36	39	40	24	24	24	24	34	36	39	41	29	30	31	31
23	23	10-0"	33	36	39	40	24	24	24	24	34	36	39	41	29	30	31	31
24	24	10-0"	33	36	39	40	24	24	24	24	34	36	39	41	29	30	31	31
25	25	10-0"	33	36	39	40	24	24	24	24	34	36	39	41	29	30	31	31
26	26	10-0"	33	36	39	40	24	24	24	24	34	36	39	41	29	30	31	31
27	27	10-0"	33	36	39	40	24	24	24	24	34	36	39	41	29	30	31	31
28	28	10-0"	33	36	39	40	24	24	24	24	34	36	39	41	29	30	31	31
29	29	10-0"	33	36	39	40	24	24	24	24	34	36	39	41	29	30	31	31
30	30	10-0"	33	36	39	40	24	24	24	24	34	36	39	41	29	30	31	31

TABLE 3.1

MAXIMUM COLUMN HEIGHT

COL.	COLUMN DESCRIPTION	SINGLE SPAN ATTACHED	PRESTRESSING OR MULTISPAN ATTACHED
A	FOR ALL COLUMNS SEE DETAIL 7" AND 11"	12'-0"	8'-7"
B	3" COVER/REINFORCED STEEL COL	12'-0"	11'-0"
C	3" SQUARE STEEL COLUMN	12'-0"	15'-0"
D	4" SQUARE STEEL COLUMN	12'-0"	18'-0"
E	6" SQUARE STEEL COLUMN	12'-0"	18'-0"
F	8" SQUARE STEEL COLUMN	12'-0"	18'-0"
G	10" SQUARE STEEL COLUMN	12'-0"	18'-0"
H	12" SQUARE STEEL COLUMN	12'-0"	18'-0"
I	14" SQUARE STEEL COLUMN	12'-0"	18'-0"
J	16" SQUARE STEEL COLUMN	12'-0"	18'-0"

TABLE 3.2

MAXIMUM COLUMN HEIGHT

LINE	TRIB	LOAD	MAX. COLUMN SPACING	CONC. FOOTER SIZE	AIR SPACING	MAX. COLUMN SPACING	CONC. FOOTER SIZE	AIR SPACING	MAX. COLUMN SPACING	CONC. FOOTER SIZE	AIR SPACING	MAX. COLUMN SPACING	CONC. FOOTER SIZE	AIR SPACING
25	4	10-0"	33	36	39	40	24	24	24	34	36	39	41	29
5	5	10-0"	33	36	39	40	24	24	24	34	36	39	41	29
6	6	10-0"	33	36	39	40	24	24	24	34	36	39	41	29
7	7	10-0"	33	36	39	40	24	24	24	34	36	39	41	29
8	8	10-0"	33	36	39	40	24	24	24	34	36	39	41	29
9	9	10-0"	33	36	39	40	24	24	24	34	36	39	41	29
10	10	10-0"	33	36	39	40	24	24	24	34	36	39	41	29
11	11	10-0"	33	36	39	40	24	24	24	34	36	39	41	29
12	12	10-0"	33	36	39	40	24	24	24	34	36	39	41	29
13	13	10-0"	33	36	39	40	24	24	24	34	36	39	41	29
14	14	10-0"	33	36	39	40	24	24	24	34	36	39	41	29
15	15	10-0"	33	36	39	40	24	24	24	34	36	39	41	29
16	16	10-0"	33	36	39	40	24	24	24	34	36	39	41	29
17	17	10-0"	33	36	39	40	24	24	24	34	36	39	41	29
18	18	10-0"	33	36	39	40	24	24	24	34	36	39	41	29
19	19	10-0"	33	36	39	40	24	24	24	34	36	39	41	29
20	20	10-0"	33	36	39	40	24	24	24	34	36	39	41	29
21	21	10-0"	33	36	39	40	24	24	24	34	36	39	41	29
22	22	10-0"	33	36	39	40	24	24	24	34	36	39	41	29
23	23	10-0"	33	36	39	40	24	24	24	34	36	39	41	29
24	24	10-0"	33	36	39	40	24	24	24	34	36	39	41	29
25	25	10-0"	33	36	39	40	24	24	24	34	36	39	41	29
26	26	10-0"	33	36	39	40	24	24	24	34	36	39	41	29
27	27	10-0"	33	36	39	40	24	24	24	34	36	39	41	29
28	28	10-0"	33	36	39	40	24	24	24	34	36	39	41	29
29	29	10-0"	33	36	39	40	24	24	24	34	36	39	41	29
30	30	10-0"	33	36	39	40	24	24	24	34	36	39	41	29

REGISTERED PROFESSIONAL ENGINEER
FREDRICK T. KATANURA
No. 16273
Exp. 6-30-05
APR 18 2003

REGISTERED PROFESSIONAL ENGINEER
SCHMITT
No. 23498
Exp. 6-30-02

REGISTERED PROFESSIONAL ENGINEER
ELKHART
No. 1140
Exp. 6-30-02

5.0 FREESTANDING AND ATTACHED LATTICE COMMERCIAL STRUCTURES

LIVE LOAD	TRIB WIDTH	MAX COLUMN SPACING	F C BEAM HEADER				
			CONSTRAINED FOOTER SIZES	FTR	MIN COL	TYPE	
20	70 MPH EXPOSURE B	4	27-0"	31	33	21	D
		5	28-0"	31	33	22	D
		6	27-0"	30	32	23	D
		7	26-0"	28	31	24	D
		8	25-0"	26	30	25	D
	70 MPH EXPOSURE C	4	27-0"	31	33	21	D
		5	28-0"	31	33	22	D
		6	27-0"	30	32	23	D
		7	26-0"	28	31	24	D
		8	25-0"	26	30	25	D
90 MPH EXPOSURE B	4	25-10"	30	32	23	D	
	5	26-0"	30	32	24	D	
	6	25-0"	29	31	25	D	
	7	24-0"	27	29	26	D	
	8	23-0"	25	27	27	D	
	90 MPH EXPOSURE C	4	25-10"	30	32	23	D
		5	26-0"	30	32	24	D
		6	25-0"	29	31	25	D
		7	24-0"	27	29	26	D
		8	23-0"	25	27	27	D

COL	COLUMN DESCRIPTION	MAXIMUM COLUMN HEIGHT
D	FOR ALL COLUMNS SEE DETAILS "C", "V" AND "W"	12'-0"
E	FLUTED COLUMN ALUM. D.042"	12'-0"
F	3" SQUARE STEEL COLUMN	11'-0"
G	4" SQUARE STEEL COLUMN	15'-0"
H	5" SQUARE STEEL COLUMN	18'-0"
J	6" SQUARE STEEL COLUMN	18'-0"

GENERAL METHOD FOR USING THESE TABLES

1. CHOOSE FREESTANDING OR ATTACHED, CONCRETE OR PATIO LATTICE STRUCTURE.
2. DETERMINE PROJECTION WIDTH, OVERHANG, WIND LOAD AND LIVE LOAD.
3. FIND THE MAXIMUM COLUMN SPACING ON SLAB FROM THE DESIRED COLUMN HEIGHT.
4. CHOOSE A RAFTER FROM TABLES 4.3, 4.5, 5.3 OR 5.4 THAT HAS ADEQUATE CLEARSPAN FOR YOUR NEEDS.
5. CHOOSE A HEADER FROM TABLES 4.1, 4.2 OR 5.2 THAT HAS ADEQUATE COLUMN SPACING.
6. USE THE COLUMN SPACING FOR SINGLE SPAN ATTACHED PATIO.
7. LOOK AT THE TABLES PROVIDED FOR ALL OTHERS.
8. FIND THE APPROPRIATE DETAILS IN THE CONNECTION DETAILS SHEETS.

FOR CONCRETE PATIO SLABS
FOLLOW 1-4 ABOVE
FIND THE MAXIMUM COLUMN SPACING ON SLAB FROM THE DESIRED COLUMN HEIGHT
CHOOSE A RAFTER FROM TABLE 4.1 OR 4.2 THAT CAN SPAN THAT DISTANCE FOR THAT TRIB WIDTH AND LIVE AND WIND LOAD
FIND THE APPROPRIATE DETAILS IN THE CONNECTION DETAILS SHEETS.

24" O.C. 2x6" RAFTER CLEARSPANS	MAX ROOF HEIGHT 18"	EXPOSURE B AND C	MAX OVER HANG
20	0.024	8'-10"	6'-11"
25	0.024	8'-10"	6'-7"
30	0.024	7'-8"	5'-10"
40	0.024	5'-10"	5'-4"
60	0.024	N/A	4'-9"

24" O.C. 3x6" RAFTER CLEARSPANS	MAX ROOF HEIGHT 18"	EXPOSURE B AND C	MAX OVER HANG
20	0.036	14'-6"	8'-5"
25	0.036	11'-8"	7'-7"
30	0.036	11'-8"	8'-10"
40	0.036	9'-9"	6'-11"
60	0.036	7'-4"	6'-0"

EQUIVALENT FOOTERS "F" (IN)	NONCON STRAINED STRAINER
18	18
20	20
22	22
23	23
24	24
26	26
27	27
29	29
31	31
33	33
35	35
36	36
38	38
39	39
40	40
41	41
43	43
44	44
46	46
48	48
49	49

PROJ (FT)	RAFTER OVERHANG (FT)	RAFTER OVERHANG (FT)	RAFTER OVERHANG (FT)
0	1/2	1	2 1/2
3	4	4	5
4	4	4	5
5	5	5	6
6	5	5	6
7	6	6	7
8	6	6	7
9	7	7	8
10	7	7	8
11	8	8	9
12	8	8	9
13	9	9	10
14	9	9	10
15	10	10	11
16	10	10	11
17	11	11	12
18	11	11	12
19	12	12	13
20	12	12	13
21	13	13	14
22	13	13	14
23	14	14	15
24	14	14	15
25	15	15	16
26	15	15	16
27	16	16	17
28	16	16	17
29	17	17	18
30	17	17	18
31	18	18	19
32	18	18	19
33	19	19	20
34	19	19	20
35	20	20	21
36	20	20	21
37	21	21	22
38	21	21	22
39	22	22	23
40	22	22	23
41	23	23	24
42	23	23	24

AMERITIMAX
LUMBER PRODUCTS INC.
1140 ALL PRO DRIVE
ELKHART, IN 46514
HEAD EQ EVALUATION REPORT ER-2821P
HEADER SIZES, COLUMN SPACING,
FOOTER SIZES AND ATTACHED
FREESTANDING AND ATTACHED
COMMERCIAL LATTICE STRUCTURES
SHEET 7 OF 8
DATE: 2/8/2000

REGISTERED PROFESSIONAL ENGINEER
NO. 26970
MAR 03 2009

REGISTERED PROFESSIONAL ENGINEER
FREDRIC I. KANAKOURA
NO. 16273
APR 18 2003

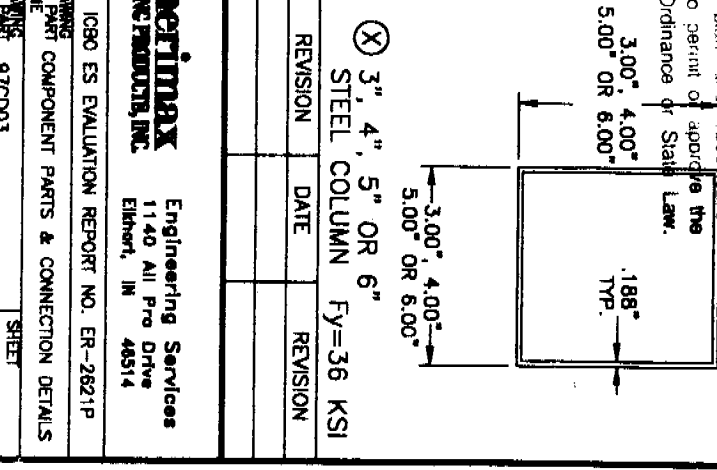
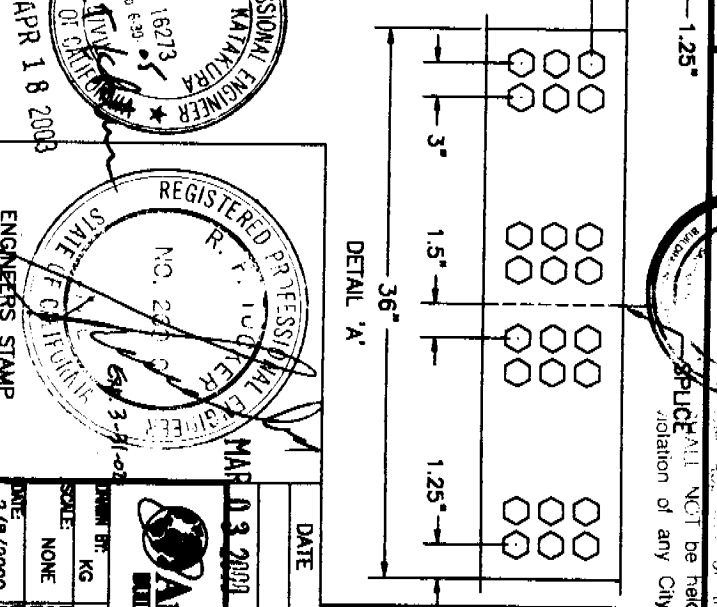
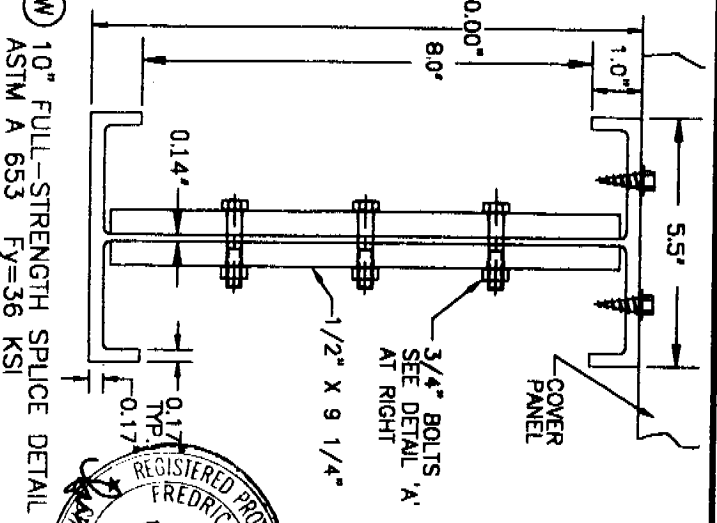
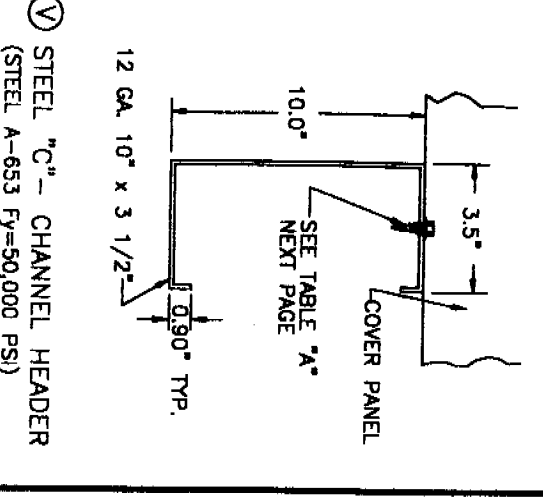
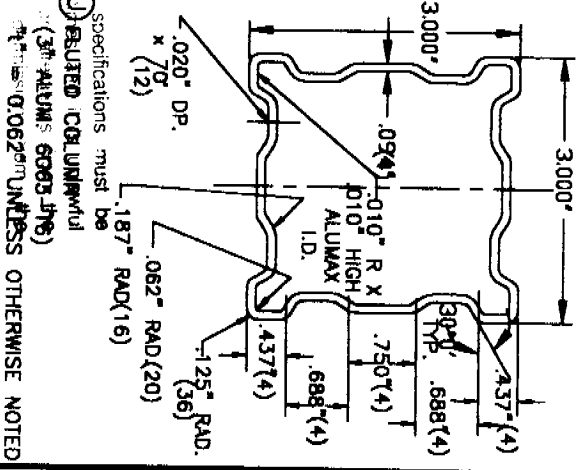
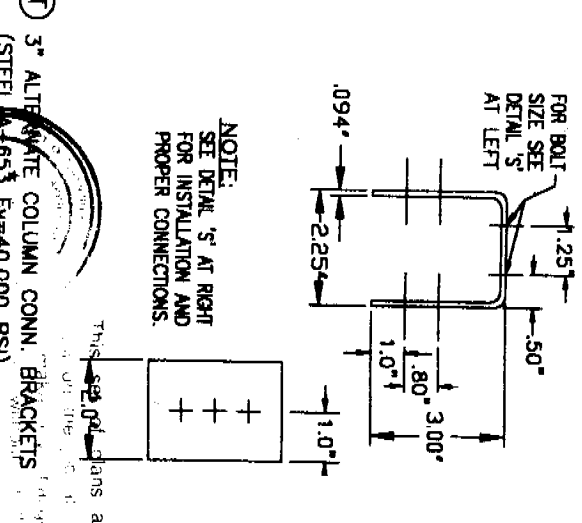
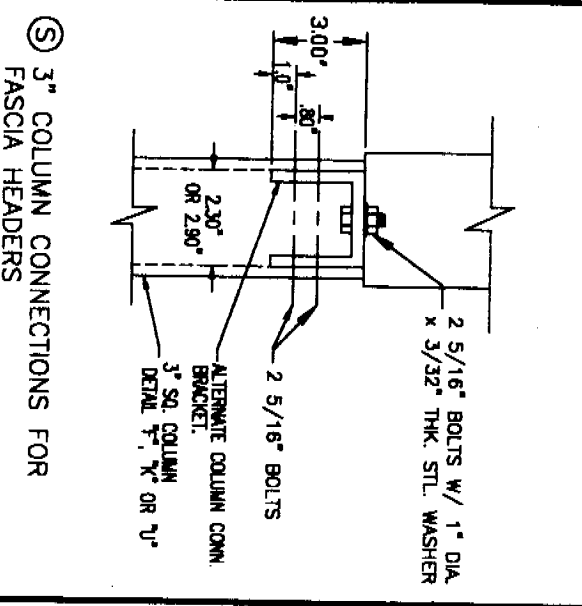
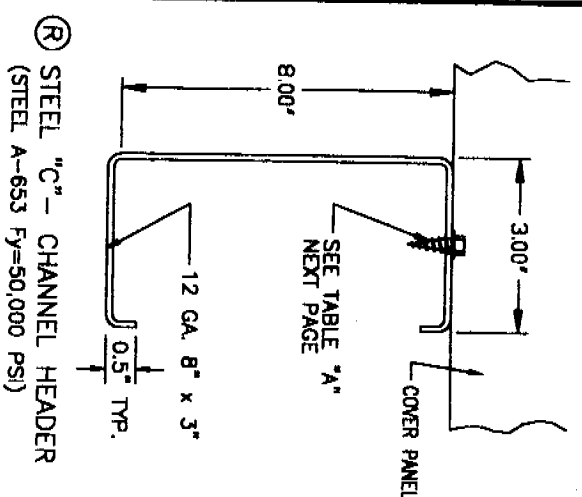

REGISTERED PROFESSIONAL ENGINEER
 FREDRIC I. KATAYUKA
 No. 16273
 Exp. 6-30-03
 STATE OF ILLINOIS
 ENGINEER OR ARCHITECT
 APR 18 2008

REGISTERED PROFESSIONAL ENGINEER
 R. T. TUCKER
 No. 227
 Exp. 3-31-08
 STATE OF ILLINOIS
 ENGINEERS STAMP

REGISTERED PROFESSIONAL ENGINEER
 R. T. TUCKER
 No. 227
 Exp. 3-31-08
 STATE OF ILLINOIS
 ENGINEERS STAMP

DATE: 03/2008
 DRAWN BY: KG
 SCALE: NONE
 DATE: 2/8/2000
 DRAWING OR PART NUMBER: 97CD03
 SHEET: 3 OF 9

Ametimax
 Engineering Services
 1140 All Pro Drive
 Ellettsville, IN 46514
 ICSO ES EVALUATION REPORT NO. ER-2621P

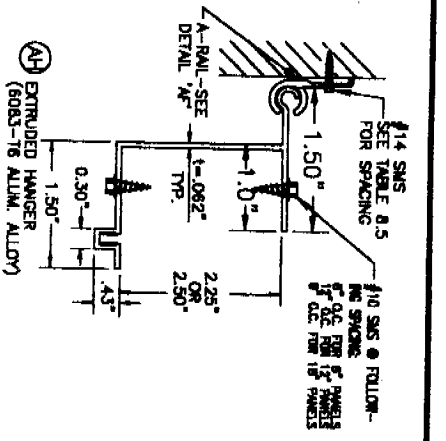
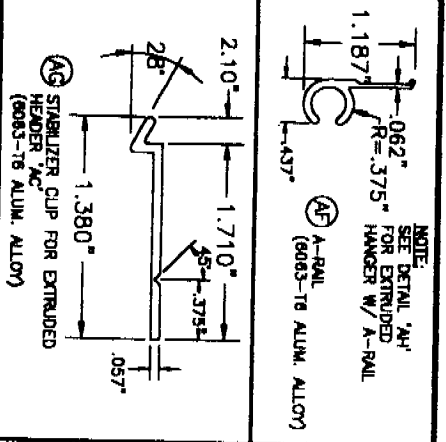
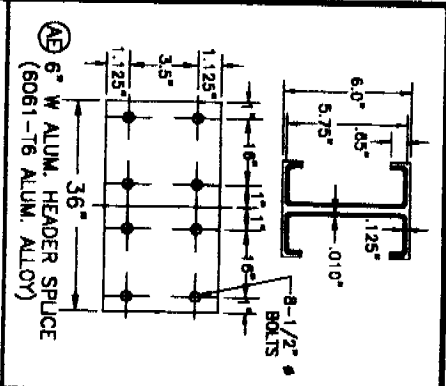

SCHEDULE OF ALLOWABLE SPANS FOR 6" & 12" PANELS ADJACENT TO SKYLIGHT PANELS.

LEVELLOAD (PSF)	*6" PANEL SPANS			*12" PANEL SPANS		
	1	2	3	1	2	3
10	11'-9"	14'-5"	17'-2"	17'-9"	11'-0"	13'-3"
20	8'-8"	10'-6"	12'-6"	13'-5"	7'-11"	10'-4"
25	7'-2"	9'-5"	11'-3"	12'-1"	7'-2"	9'-3"
30	6'-1"	8'-8"	10'-4"	11'-1"	6'-7"	8'-6"

* USE A MINIMUM OF (1) SKYLIGHT PANEL PER (2) - 6' ROOF PANELS AND (1) SKYLIGHT PANEL PER (2) - 12' ROOF PANELS FOR SKYLIGHT TO PANEL CONNECTIONS. USE THE SAME NUMBER OF SCREWS AS PANEL TO HEADER. SEE TABLE 'A' DETAIL AE

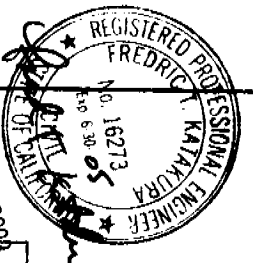
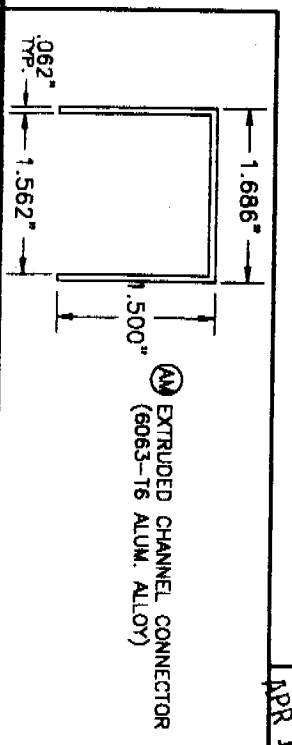
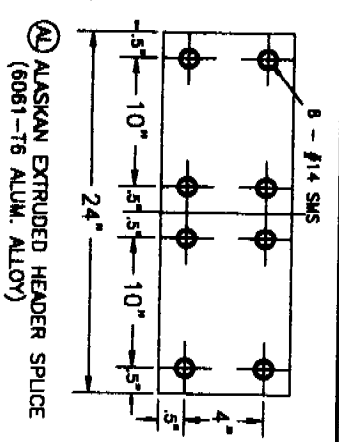
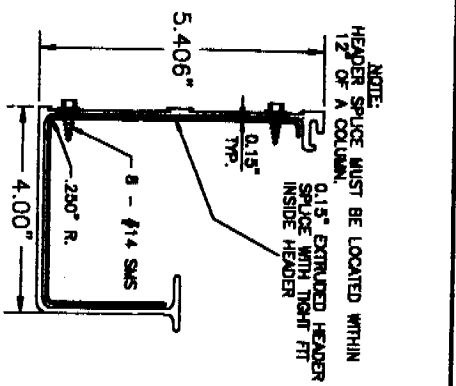
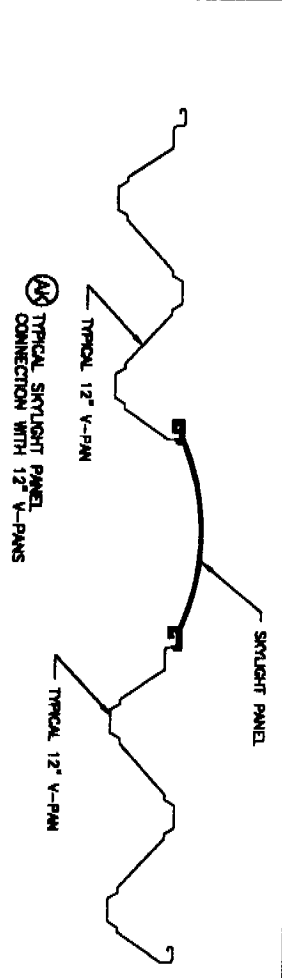

APR 18 2000

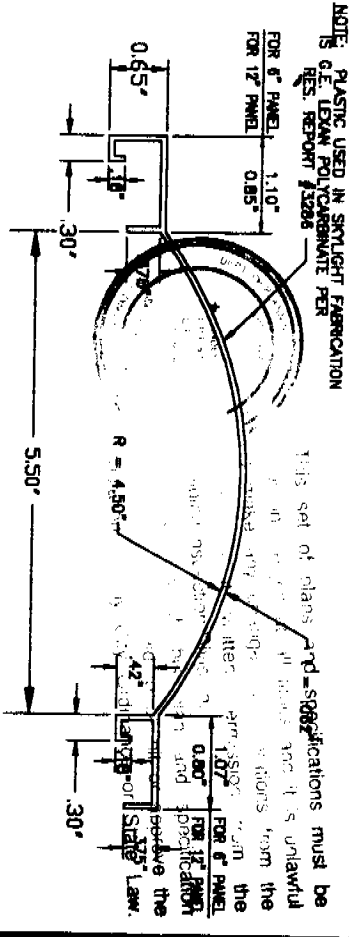

NOTE: SEE SCHEDULE ABOVE FOR ALLOWABLE SPANS FOR PANELS ADJACENT TO SKYLIGHT PANELS & NUMBER OF ROOF PANELS NEEDED FOR 1 SKYLIGHT PANEL.

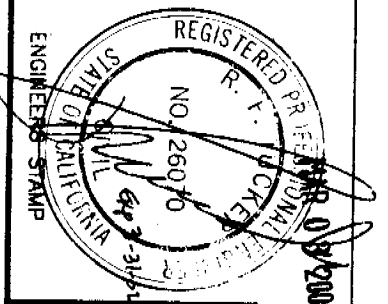

Amerimax Engineering Services
 1140 All Pro Drive
 Elkhart, IN 46514

ICBO ES EVALUATION REPORT NO. ER-2621P

DATE	REVISION	DATE	REVISION
2/8/2000			

SCALE: NONE
 DRAWING OR PART COMPONENT PARTS & CONNECTION DETAILS
 SHEET 5 OF 9

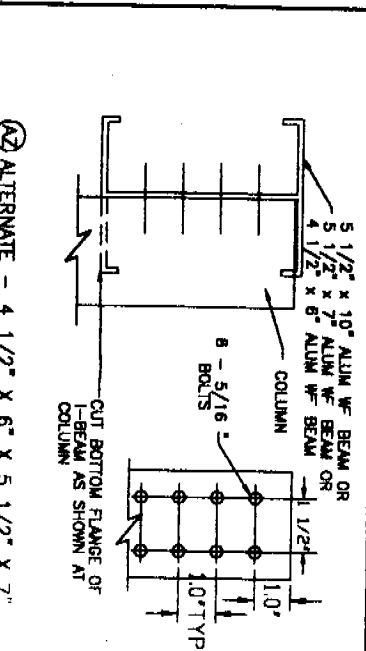
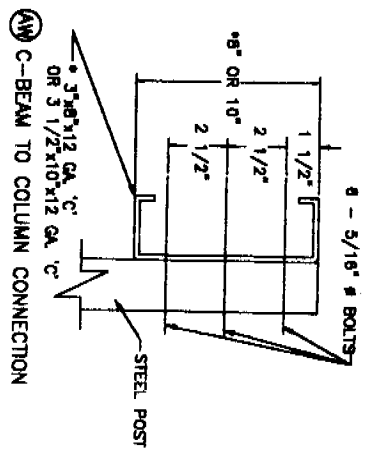

(B) ALTERNATE - 4 1/2\"/>

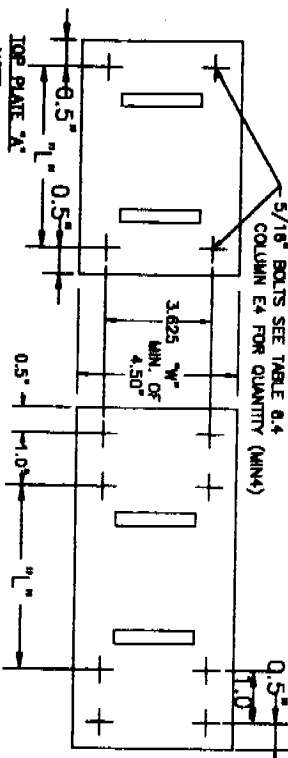

(C) TOP PLATES 'A', 'B', AND SCHEDULE 'B' FOR TOP PLATE CONNECTIONS WITH TOP BEAMS (Y, Z, AA) ON STEEL POSTS

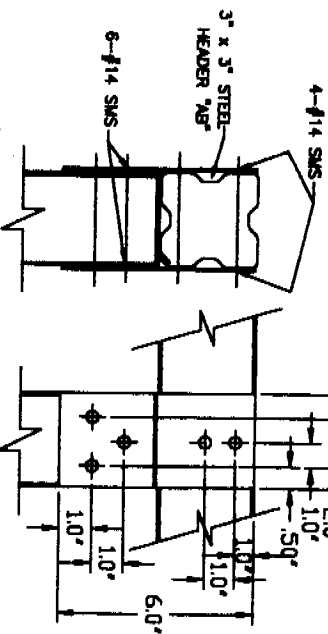

(D) COLUMN TO HEADER CONNECTION FOR 3\"/>

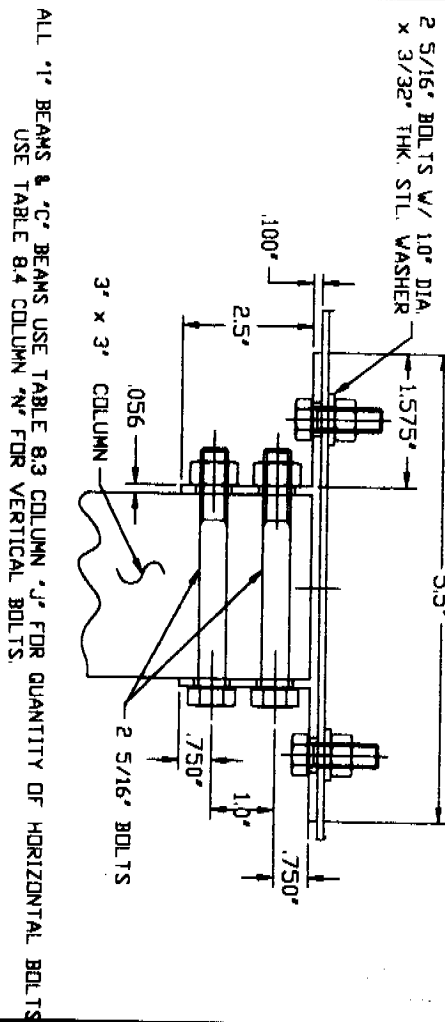

(E) ALTERNATE 3\"/>

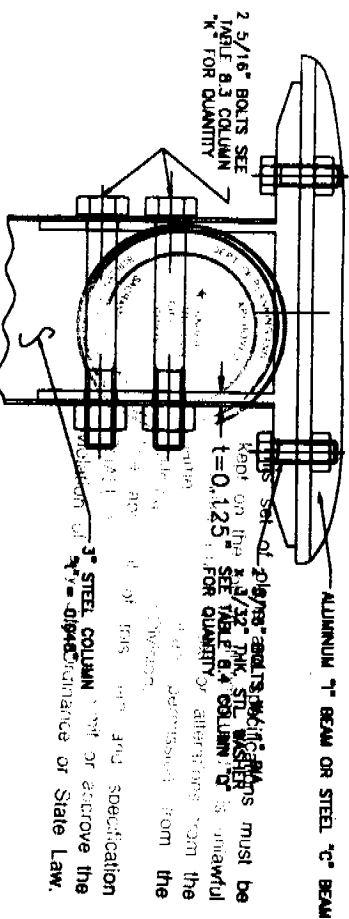

(F) 3\"/>



ENGINEERS STAMP

DATE:	2/8/2000	REVISION:	97CD07	SHEET:	7 OF 9
SCALE:	NONE	REVISION:			
DRAWING:	ICBO ES EVALUATION REPORT NO. ER-2621P	DATE:			
PROJECT:	Engineering Services	REVISION:			
CLIENT:	1140 All Pro Drive	DATE:			
LOCATION:	Elkhart, IN 46514	REVISION:			

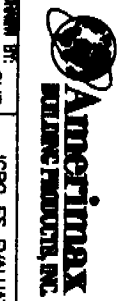

Engineering Services
1140 All Pro Drive
Elkhart, IN 46514

1140 All Pro Drive
Elkhart, IN 46514

ICBO ES EVALUATION REPORT NO. ER-2621P
Engineering Services
1140 All Pro Drive
Elkhart, IN 46514

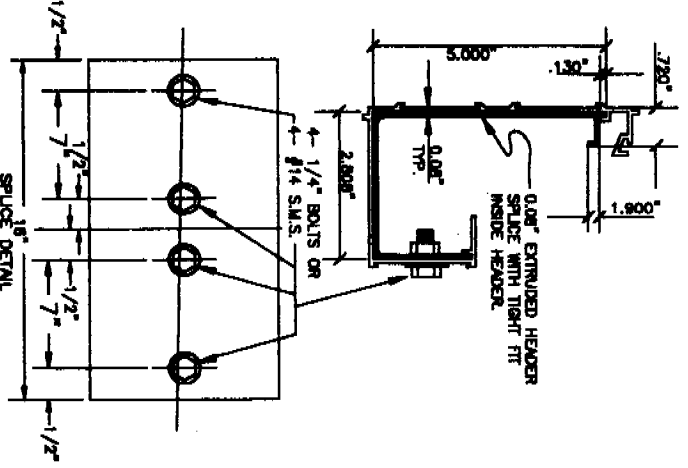

ⓑ 5 1/2" EXTRUDED HEADER SPLICE
(6063-T6 ALUM. ALLOY)

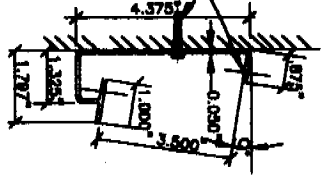

ⓑ 3 1/2" C RAIL
(6063-T6 ALUM. ALLOY)

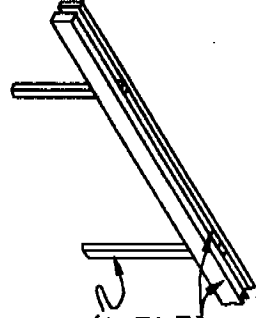

ⓑ ALTERNATE 2-2" X 6 1/2" HEADERS

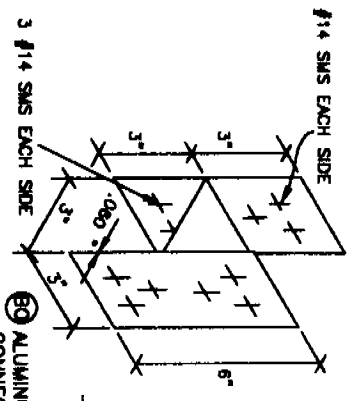

ⓑ ALUMINUM 'H' BRACKET FOR
CONNECTING COLUMN TO HEADER
(6063-T6 ALUM. ALLOY)

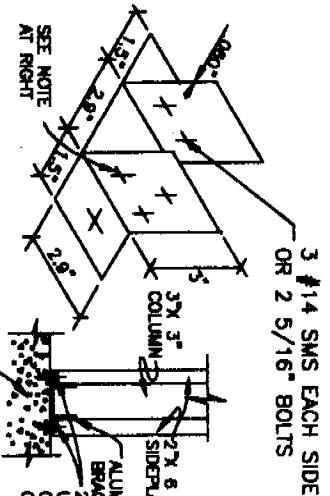

ⓑ ALUMINUM FOOTING BRACKET FOR CONNECTING
COLUMN TO CONC. SLAB OR FOOTING
(6063-T6 ALUM. ALLOY)

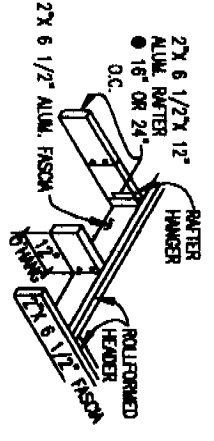
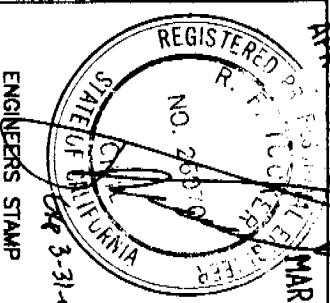
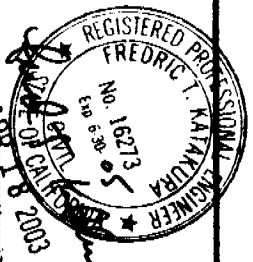

ⓑ ALTERNATE-DECORATIVE
FASCIA TRIM

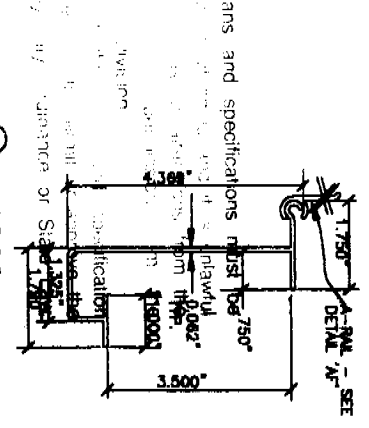

ⓑ 3 1/2" J HANGER
(6063-T6 ALUM. ALLOY)

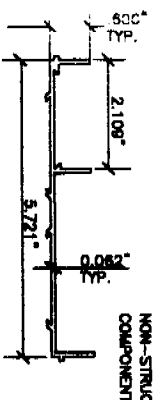

ⓑ 5 1/2" EXTRUDED SIDE FASCIA
(6063-T6 ALUM. ALLOY)

DATE	REVISION	DATE	REVISION
2/8/2000			

NON-STRUCTURAL COMPONENT

Amerimax Engineering Services
 1140 All Pro Drive
 Elkhart, IN 46514

ICBQ ES EVALUATION REPORT NO. ER-2621P
 DRAWING NO. KG
 SCALE: NONE
 PREPARED BY: NONE
 CHECKED BY: NONE
 DATE: 2/8/2000
 PART NUMBER: 97CDD09
 SHEET: 9 OF 9

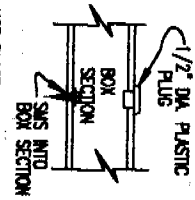

NOTE: USE PLASTIC PLUG TO FILL 1/2" DIA. ACCESS HOLES USED WHEN ATTACHING S.M.S. INTO ANOTHER BOX SECTION IN WHICH THE S.M.S. LENGTH WOULD EXCEED 2 1/2".

L10 PLASTIC PLUG DETAIL

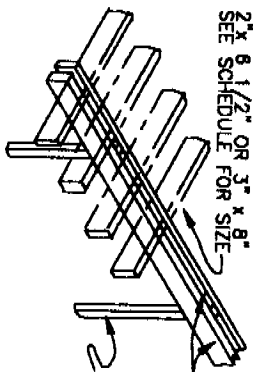

L11 ALTERNATE 2-2" X 6 1/2" HEADERS

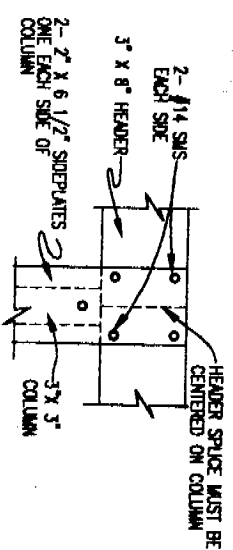

L16 HEADER SPLICE DETAIL

This set of plans and specifications must be kept on the job at all times and it is unlawful to alter, amend, or delete any part of the same without written permission from the State of Illinois Department of Transportation.

The approval of this plan and specification SHALL NOT be held to permit or approve the violation of any City Ordinance or State Law.

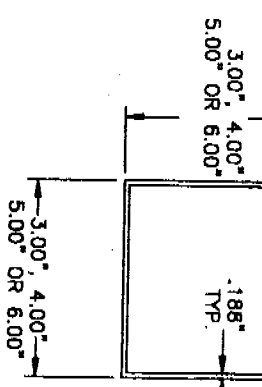

L32 3" x 4" x 5" OR 6" STEEL COLUMN
FY=36 KSI

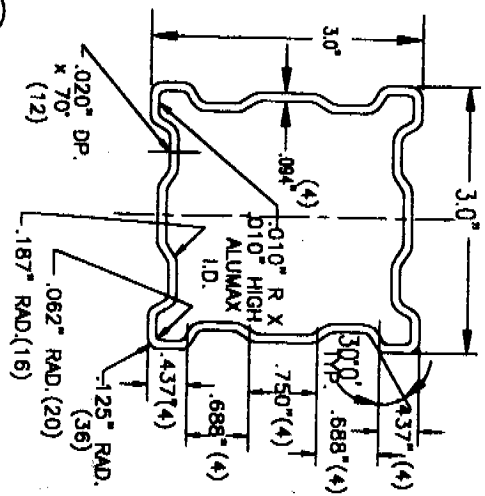

L31 FLUTED COLUMN
(3" ALUM. 6063-T6)
T = 0.062" UNLESS OTHERWISE NOTED

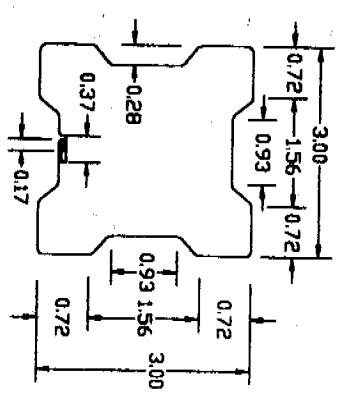

L30 3" ALTERNATE COLUMN
(3003-H16 ALUM. ALLOY OR A-446 Fy=40 KSI STEEL)
NOTE: COLUMNS MAY BE TRIMMED W/FLEX-ALUM. FACING.

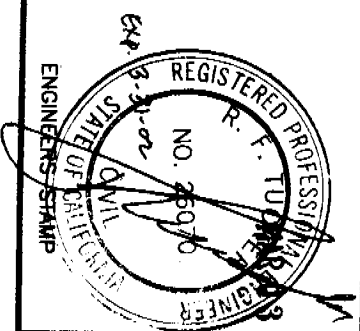
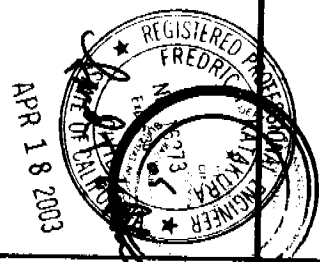

DATE	REVISION	DATE	REVISION

Ametimax
 Engineering Services
 1140 All Pro Drive
 Elkhart, IN 46514

DRAWING NO. 97L103
 SHEET 2 OF 4

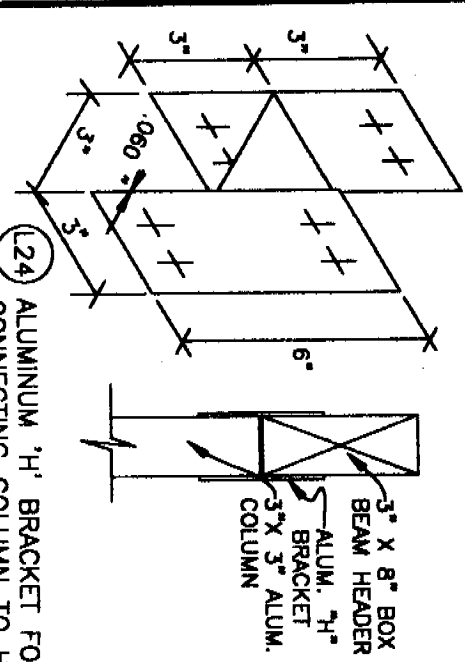

124 ALUMINUM 'H' BRACKET FOR CONNECTING COLUMN TO HEADER (6063-T6 ALUM. ALLOY)

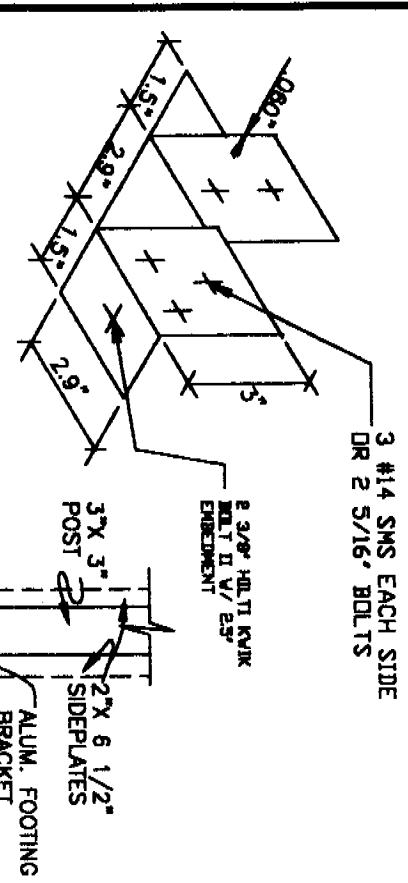

127 ALUMINUM FOOTING BRACKET FOR CONNECTING POST TO CONC. SLAB OR FOOTING (6063-T6 ALUM. ALLOY)

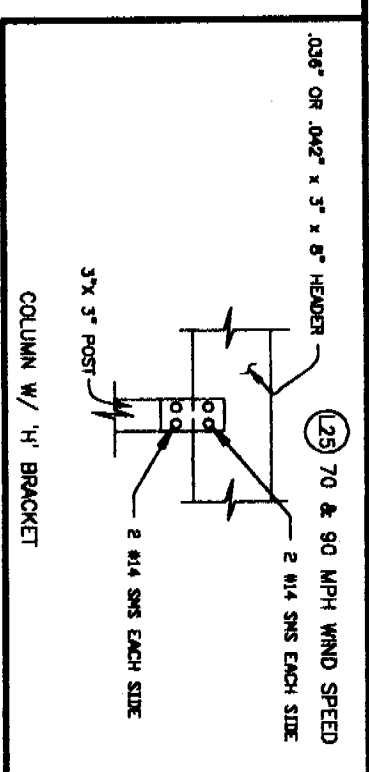

125 70 & 90 MPH WIND SPEED COLUMN W/ 'H' BRACKET

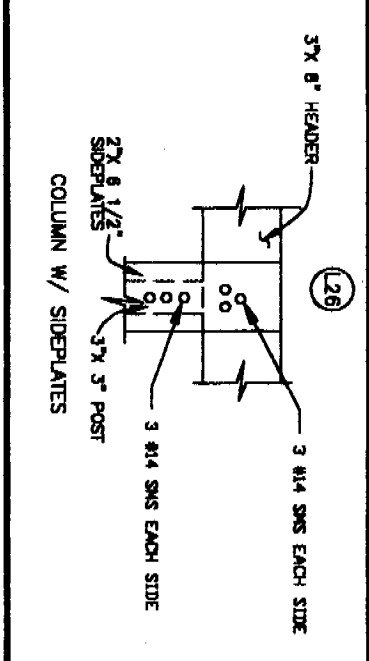

126 3x8" HEADER COLUMN W/ SIDEPLATES

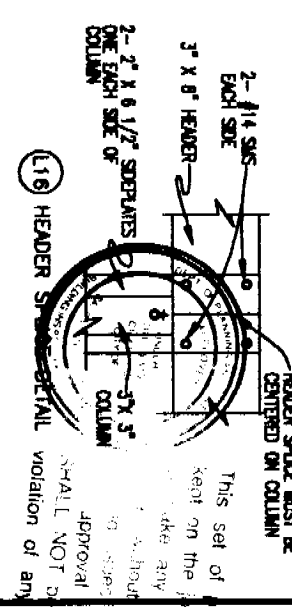

116 HEADER SPlice DETAIL

This set of plans and specifications must be kept on the job at all times and it is understood that any changes or alterations from the written drawings shall be approved in writing by the Engineer of this Division. Approval of this plan and specification shall NOT be held to permit or approval of any violation of any City Ordinance.

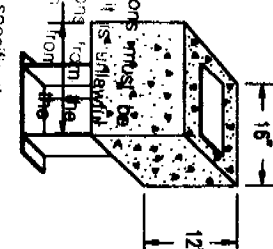

123 Stake in CONCRETE FOOTING

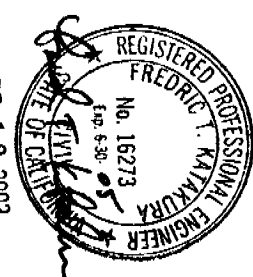

APR 18 2003

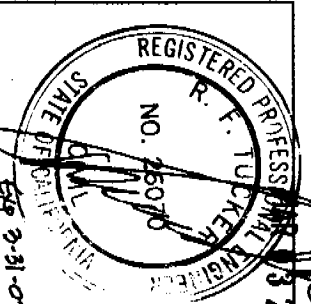

APR 18 2003

DATE	REVISION	DATE	REVISION
2/8/2000			

Amerimax Engineering Services
 1140 All Pro Drive
 Ellettsville, IN 46014
 ICSO ES EVALUATION REPORT NO. ER-2621P
 DRAWING COMPONENT PARTS & CONNECTION DETAILS
 FOR PANO & COMMERCIAL LATTICE STRUCTURES
 DATE: 2/8/2000
 SHEET: 4 OF 4

5/16" BOLTS W/ 1" DIA.
 x 3/32" THK. STL. WASHER
 TO 8" STEEL 'C' BEAM
 SEE TABLE B.4 COLUMN E.4
 FOR QUANTITY

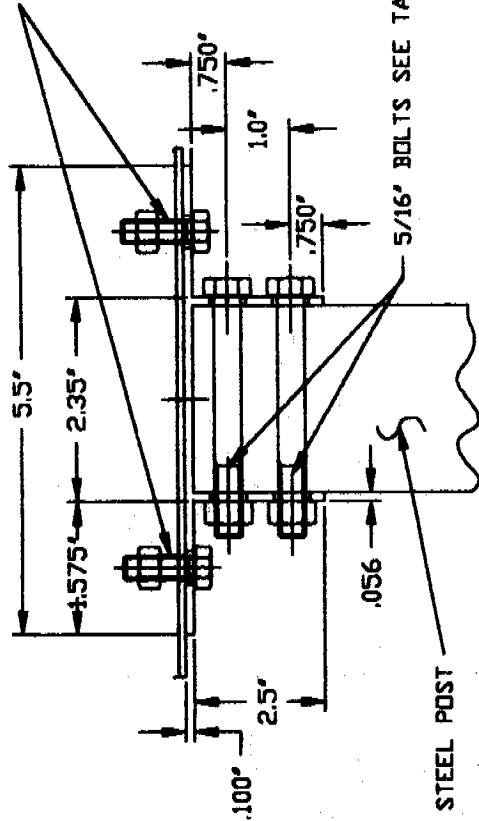

5/16" BOLTS SEE TABLE B.3 COLUMN 'M' FOR QUANTITY

.048 x 3" x 3" STEEL POST

(A) ALTERNATE 3" SQ. COLUMN CONNECTOR BRACKET
 (6063-T6 ALUM. ALLOY)

DETAIL 3" X 8" - 1 FOR ATTACHED STRUCTURES
 COLUMN TO WRAPPED 3" X 8" X 12 GA.
 'C' BEAM HEADER CONNECTIONS



3" X 8" BOX BEAM WRAP

(L23) 3" X 12" X 12 GA. STL. 'C' BEAM
 WRAP W/ 3" X 8" ALUM. BOX BEAM

APR 18 2003

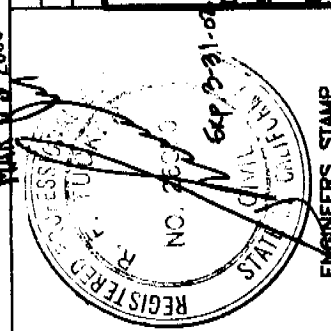
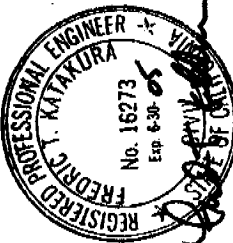

DATE	REVISION	DATE	REVISION

DATE	2/8/2000	PROJECT	97L103
SCALE	NONE	SHEET	3 OF 4
NO. OF KG	1080	ES EVALUATION REPORT NO.	ER-2821P
Engineering Services 1140 All Pro Drive Elmhurst, IL 60120			
COMPONENT PARTS & CONNECTION DETAILS FOR PART FOR PATIO & COMMERCIAL LATTICE STRUCTURES			

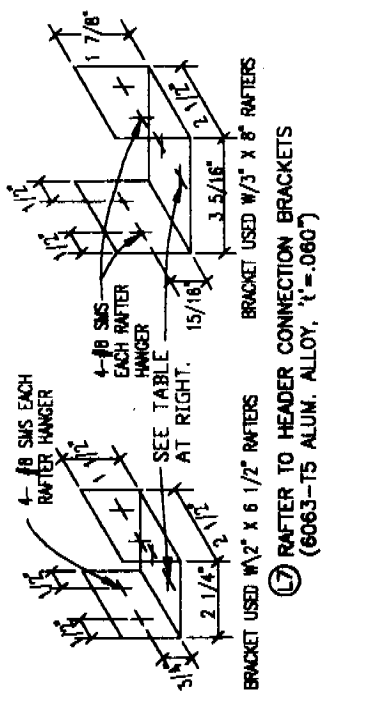
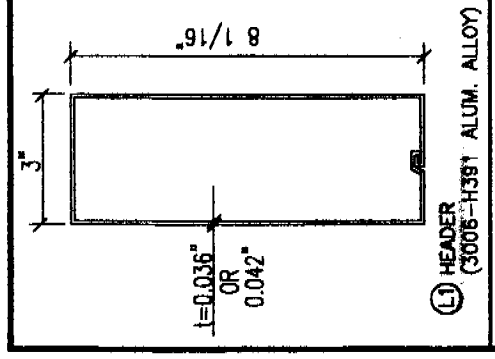
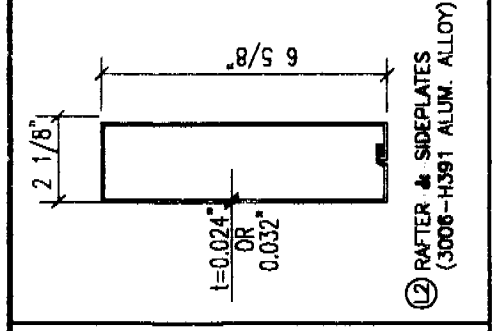
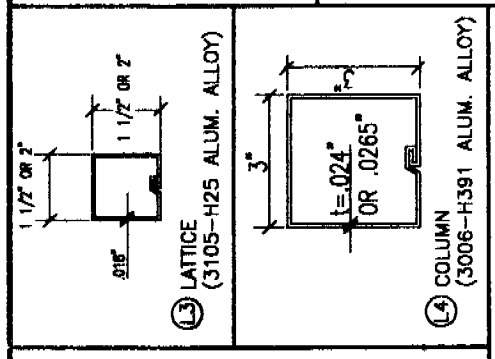
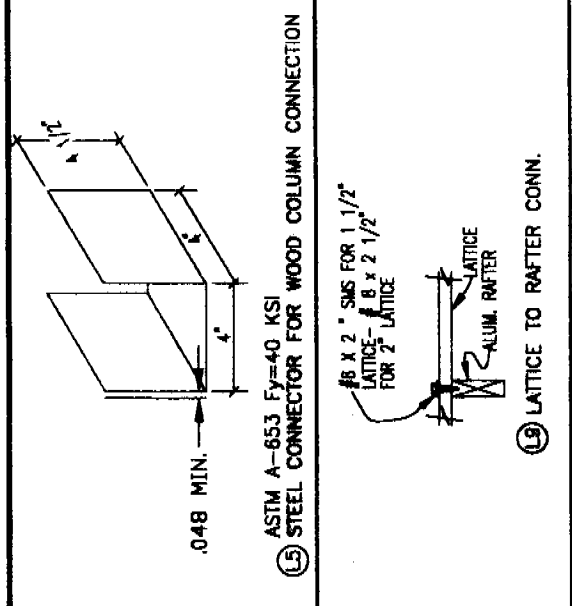
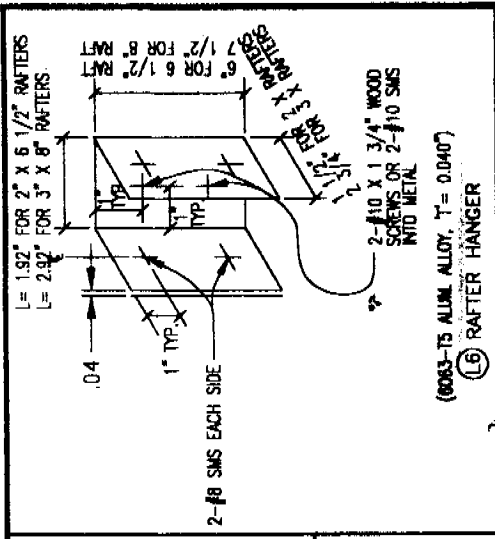

HEADER GAGE	HEADER	DETAIL	MAXIMUM WIND LOAD	MAX TRIB	FASTENING
.042	3' x 8"	L1	90 MPH PATIO	6'	2-#8 SMS EACH BRKT. 3-#8 SMS EACH BRKT.
.036	3' x 8"	L1	90 MPH PATIO	5'	2-#8 SMS EACH BRKT. 4-#8 SMS EACH BRKT.
.032	DBL 2 x 6	L11	90 MPH PATIO	10'	3-#8 SMS EACH BRKT.
.094	8" STEEL C	L23	90 MPH 90 EXP C	22' 10'	2-#14 SMS EACH BRKT. 2-#14 SMS EACH BRKT.

MAR 03 2000

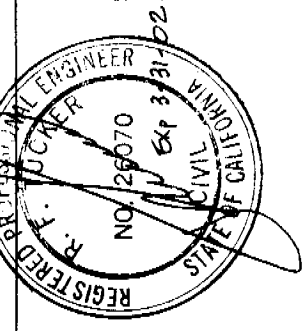
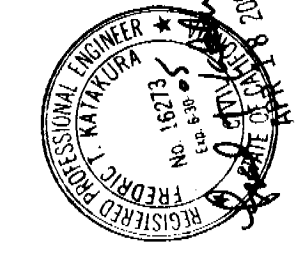
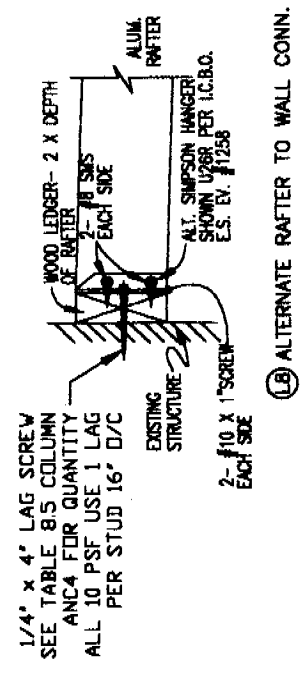

DATE	REVISION	DATE	REVISION

DRAWING NO. ER-2621P
 DRAWING COMPONENT PARTS & CONNECTION DETAILS
 DRAWING NAME FOR PATIO & COMMERCIAL LATTICE STRUCTURES
 DRAWING NUMBER 97L101
 SHEET 1 OF 4

Amerimax
BUILDING PRODUCTS, INC.
 Engineering Services
 1140 All Pro Drive
 Elkhart, IN 46514

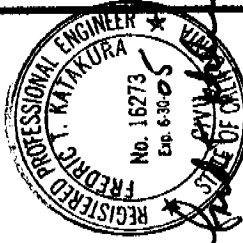

APR 18 2000

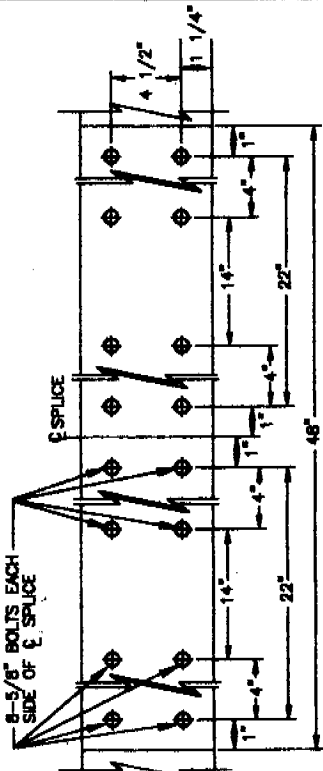

ⓑF 7' X 5 1/2" ALUM. I-BEAM SPLICE BOLT LAYOUT

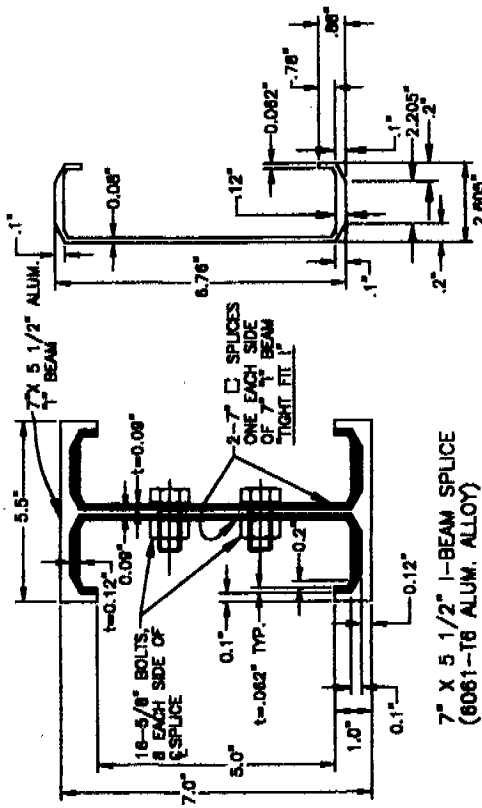

ⓑE SPLICE DETAILS
7' X 5 1/2" I-BEAM SPLICE
(8061-T6 ALUM. ALLOY)

ⓑE SPLICE DETAILS
7" C SPLICES
(8061-T6 ALUM. ALLOY)

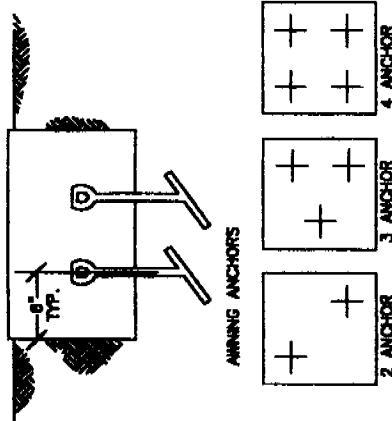

2, 3, OR 4 ANCHOR DETAIL

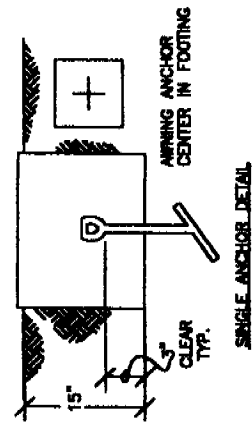

ⓑ ANCHOR DETAILS
FOR ATTACHED STRUCTURES

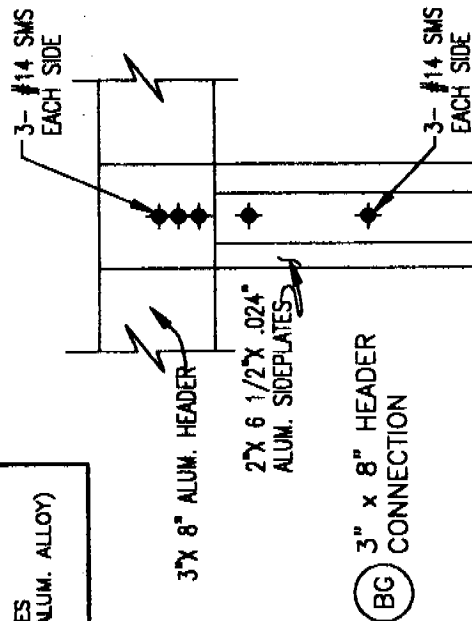

ⓑG CONNECTION
3" X 8" HEADER

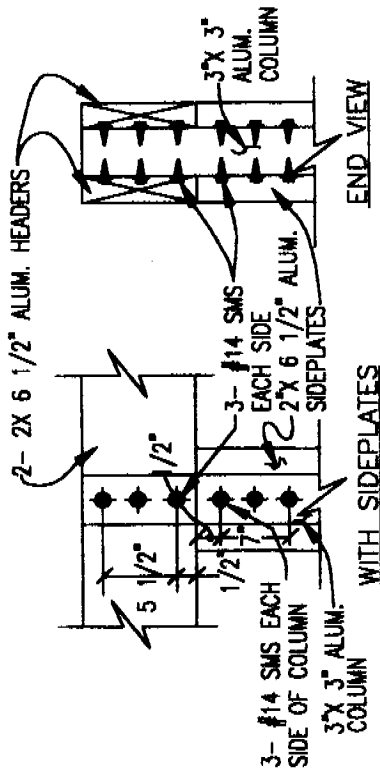

ⓑH DOUBLE 2" X 6 1/2" HEADER CONNECTION

FOOTING d (IN)	ALTERNATE FOOTING SIZE	NO. OF ANCHORS
18	12" X 12" X 15"	1
20	15" X 15" X 15"	1
22	18" X 18" X 15"	1
24	20" X 20" X 15"	1
26	20" X 20" X 15"	1
28	24" X 24" X 15"	2
30	24" X 24" X 15"	2
32	24" X 24" X 15"	3
34	24" X 24" X 15"	4
36	24" X 24" X 15"	4

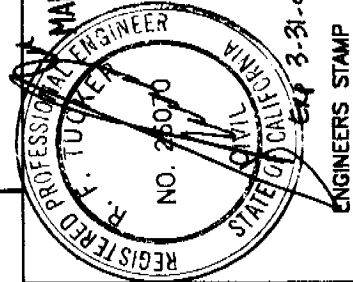

DATE	REVISION	DATE	REVISION
MAR 03 2000			

Engineering Services
1140 Ali Pro Drive
Elkhart, IN 46514

Amertimax
BUILDING PRODUCTS, INC.

ICBO ES EVALUATION REPORT NO. ER-2621P
SCALE: NONE
DATE: 2/9/2000
SHEET NUMBER: 8 OF 9



APR 18 2003

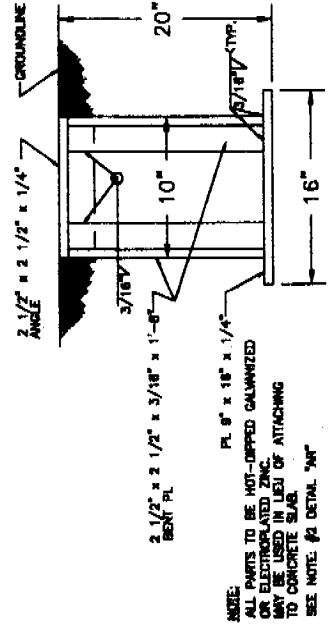

AP SAFETY STAKE (ALTERNATE TO CONCRETE SLAB ATTACHMENT)

NOTE: ALL PARTS TO BE HOT-DIPPED GALVANIZED OR ELECTROPLATED ZINC. MAY BE USED IN LIEU OF ATTACHING TO CONCRETE SLAB. SEE NOTE #2 DETAIL "AV".

SCHEDULE T ¹ - COLUMN TO FOOTING CONNECTIONS FOR 18" TO 42" FOOTING SIZES			REQUIRED TENSION FOR ANCHOR BOLTS
FOOTING SIZE "d" (INCHES)	HILTI FASTENER (OR EQUIV.) SIZE	CONNECTION TO COLUMN TUBE	
18"	2-1/4" x 2" d	1-5/16" BOLT	4300
20"	2-3/8" x 2 1/2"	2-3/16" BOLTS	5600
22"		2-3/16" BOLTS	6500
24"		2-3/8" BOLTS	7900
26"	2-1/2" x 3 1/2"	3-5/16" BOLTS	13300
28"			13300
30"			16700
32"	2-5/8" x 4" d		20800
34"			N/A
36"			N/A
38"			N/A
40"			N/A
42"		3-3/8" BOLTS	N/A

*"d" SIZE IN ANCHOR BOLT OR HILTI FASTENER SIZES INDICATES DEPTH OF EMBEDMENT. EXAMPLE: 2 1/2" d INDICATES 2 1/2" EMBEDMENT OF ANCHOR OR EQUIV. TO HILTI FASTENERS. ALTERNATE MUST BE ICBO ES. APPROVED TO PROVIDE ALLOWABLE TENSION EQUAL TO "REQ'D" TENSION FOR ANCHOR BOLT VALUES SHOWN. HILTI INDICATES HILTI KB-II ANCHOR BOLTS PER ICBO E.S. EV #4627.

AV FOOTING SCHEDULE

DATE	REVISION	DATE	REVISION

Amcrimax
Engineering Services
1140 All Pro Drive
Elkhart, IN 46514

ICBO ES EVALUATION REPORT NO. ER-2621P

DRWING NO. 26070

SCALE: NONE

DATE: 2/8/2000

97CD08

6 OF 9

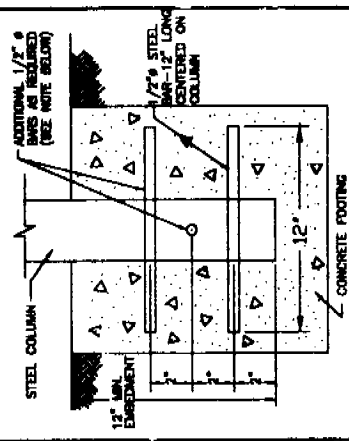

NOTE: 1/2" STEEL BAR FOR FOOTING UP TO USE 3 - 1/2" BARS FOR FOOTINGS UP TO 42" CUBE AND 3 - 1/2" BARS FOR FOOTINGS UP TO 30" CUBE.

AV ALTERNATE PRESTANDING STRUCTURE COLUMN TO FOOTING CONNECTION DETAIL

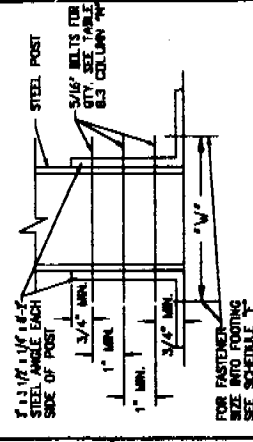

FOR FASTENER SIZE INTO FOOTING SEE SCHEDULE T¹ @ RIGHT

AS ATTACHED STRUCTURE COLUMN TO FOOTING CONNECTION DETAIL "d" = 18" TO 32" HILTI FASTENER ALTERNATE

REQUIRED "W" (WIDTH)	MINIMUM "W" (WIDTH)
1/4"	3"
3/8"	4 1/2"
1/2"	6"
5/8"	7 1/2"
3/4"	9"

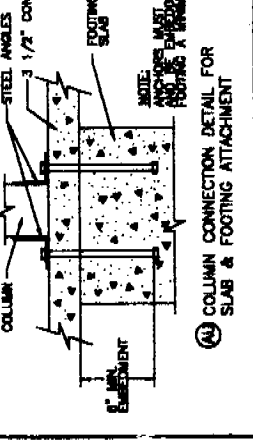

AV COLUMN CONNECTION DETAIL FOR SLAB & FOOTING ATTACHMENT

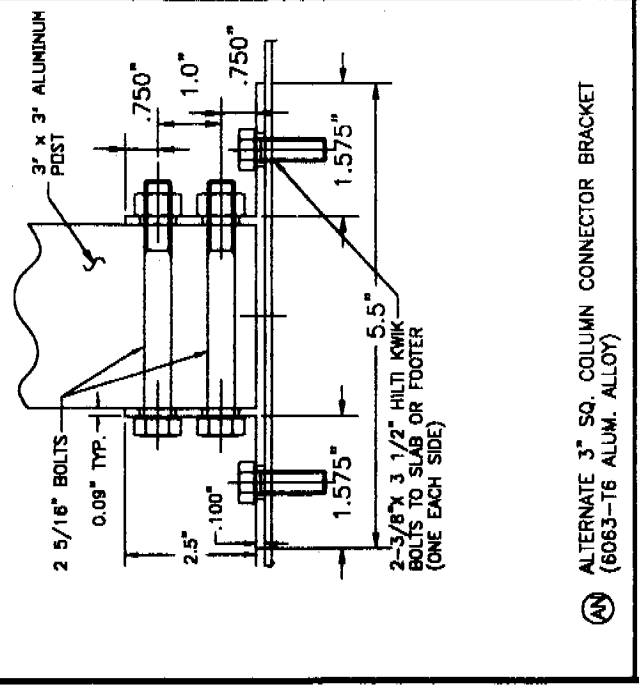

AN ALTERNATE 3" SQ. COLUMN CONNECTOR BRACKET (6063-T6 ALUM. ALLOY)

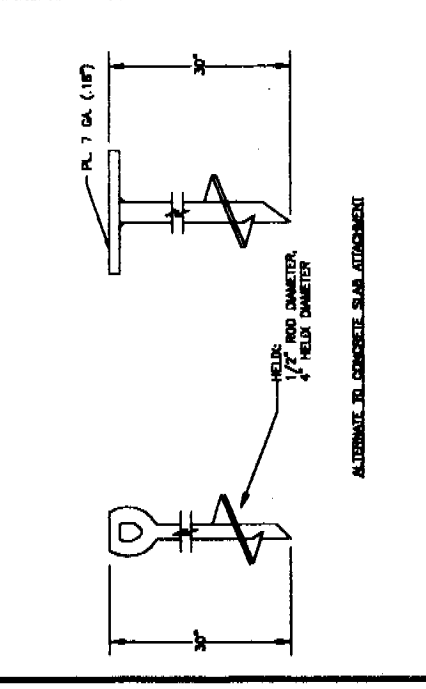

NOTE: ALL PARTS TO BE HOT-DIPPED GALVANIZED OR ELECTROPLATED ZINC. MAY BE USED IN LIEU OF ATTACHING TO CONCRETE SLAB. FABRICATION OF ANCHORS AND SAFETY STAKES IS BEYOND THE SCOPE OF THIS REPORT. FABRICATION DETAILS AND QUALITY CONTROL PROGRAM MUST BE SUBMITTED TO BUILDING OFFICIAL FOR APPROVAL. ANCHOR ANCHORS MAY BE USED IN THE FOLLOWING TYPES OF SOIL: SAND, GRAVEL, CLAY, SANDY GRAVEL, SILTY GRAVEL, SILTY SAND, CLAYEY SAND, CLAYEY GRAVEL, SANDY CLAY, SILTY CLAY, AND CLAYEY SILT.

AR AWNING ANCHOR

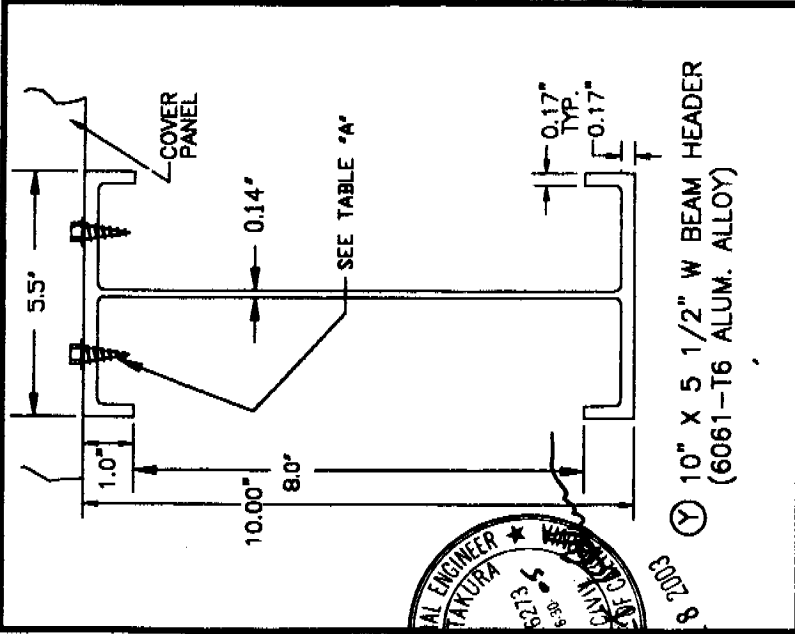

(Y) 10" X 5 1/2" W BEAM HEADER
(6061-T6 ALUM. ALLOY)

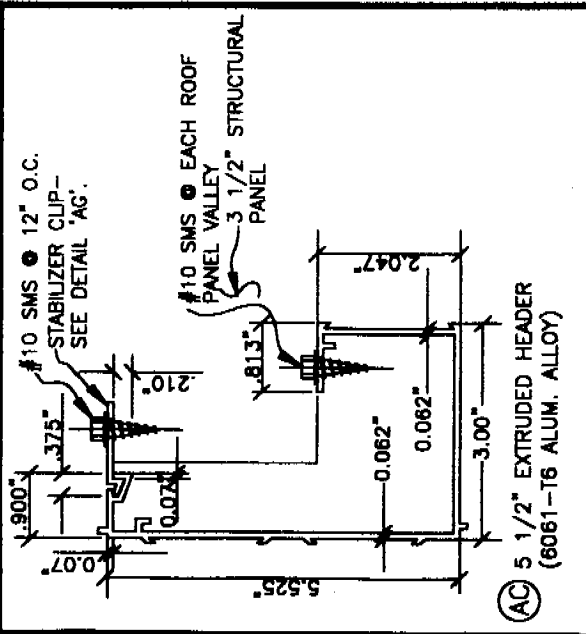

(AC) 5 1/2" EXTRUDED HEADER
(6061-T6 ALUM. ALLOY)

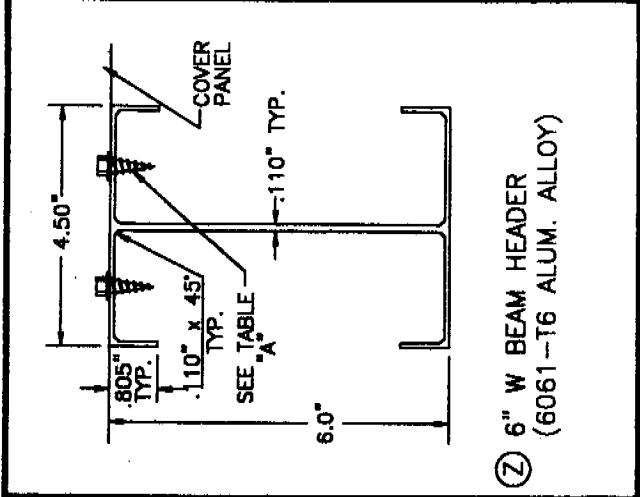

(Z) 6" W BEAM HEADER
(6061-T6 ALUM. ALLOY)

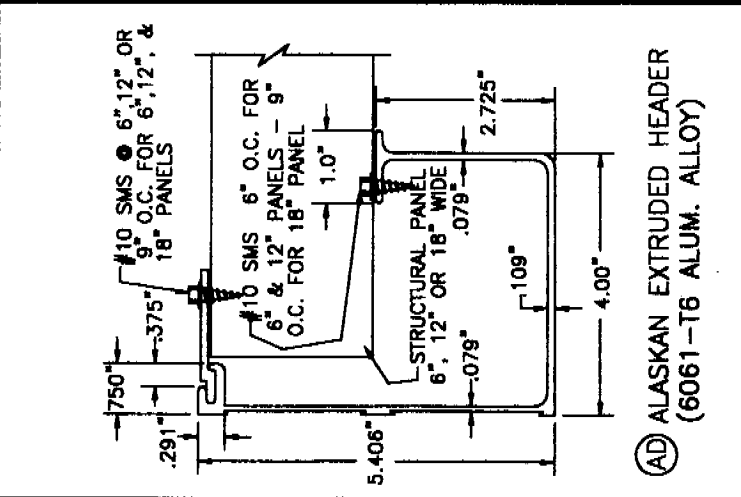

(AD) ALASKAN EXTRUDED HEADER
(6061-T6 ALUM. ALLOY)

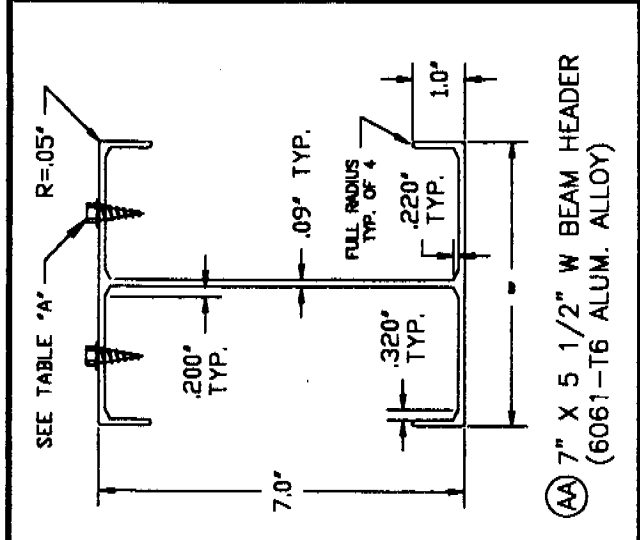

(AA) 7" X 5 1/2" W BEAM HEADER
(6061-T6 ALUM. ALLOY)

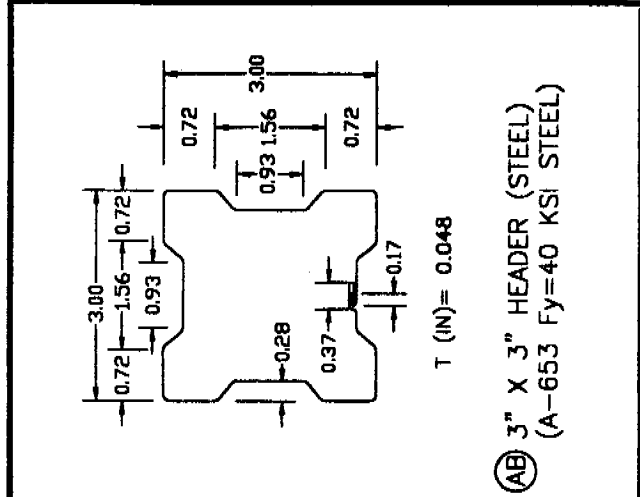

(AB) 3" X 3" HEADER (STEEL)
(A-653 Fy=40 KSI STEEL)

FASTENERS REQUIRED FOR PANEL TO HEADER CONNECTIONS

TABLE "A"

MAX. WIND LOAD	HEADER DESCRIPTION	MAX. TRIB WIDTH	FASTENING SCHEDULE	NOTE'S
90 MPH PATIO	ALL FASCIA STEEL CLOVER, C BEAMS, I BEAMS STEEL CLOVER, C BEAMS, I BEAMS	10' 12' 21'	2-#10 SMS PER 12' PANEL 2-#14 SMS PER 12' PANEL 3-#14 SMS PER 12' PANEL	
70 MPH EXP C AND 90 MPH EXP B	ALL FASCIA STEEL CLOVER, C BEAMS, I BEAMS STEEL CLOVER, C BEAMS, I BEAMS	10' 16' 16'	2-#10 SMS PER 12' PANEL 3-#14 SMS PER 12' PANEL 2-#14 SMS PER 12' PANEL	SEE #1 SEE #2
90 MPH EXP C	ALL FASCIA STEEL CLOVER, C BEAMS, I BEAMS STEEL CLOVER, C BEAMS, I BEAMS	10' 16' 16'	2-#14 SMS PER 12' PANEL 4-#14 SMS PER 12' PANEL 3-#14 SMS PER 12' PANEL	SEE #1 SEE #2

(AE) 6' PANEL USE 50% LESS SCREWS
18' PANELS USE 50% MORE SCREWS
#1 .018 & .024 PANELS
#2 .032 & .036 PANELS

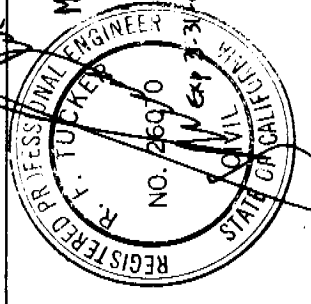

DATE	REVISION	DATE	REVISION
MAR 03 2000			

Amerimax
BUILDING PRODUCTS, INC.

Engineering Services
1140 All Pro Drive
Ellettsport, IN 46514

ICBO ES EVALUATION REPORT NO. ER-2621P

SCALE: NONE

DATE: 2/8/2000

PROJECT NUMBER: 97CD04

SHEET: 4 OF 9

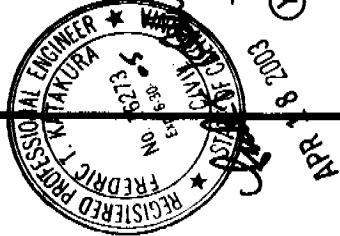

APR 8 2003

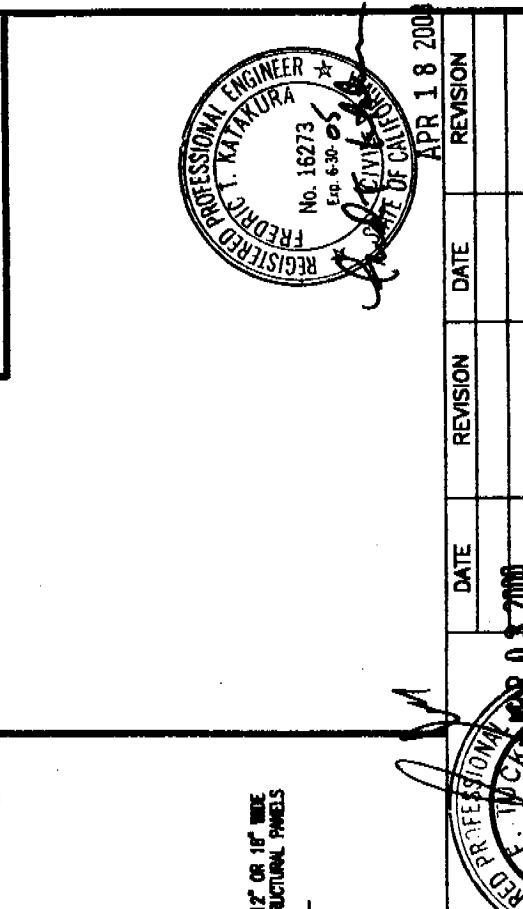
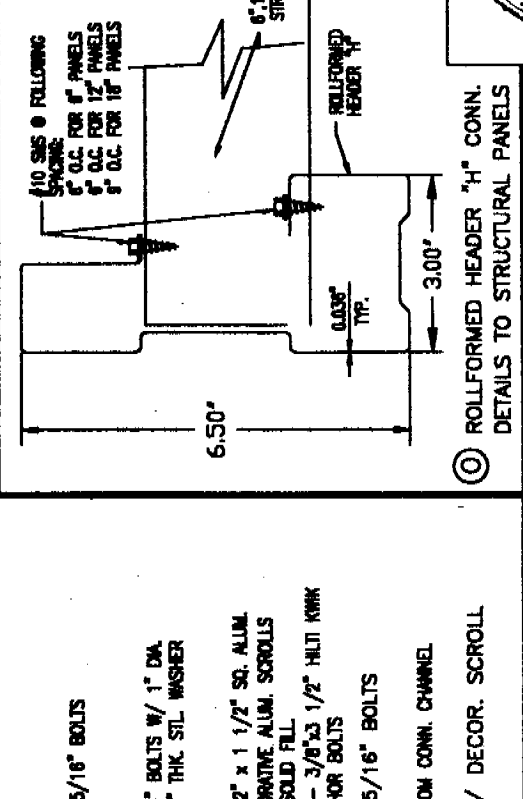
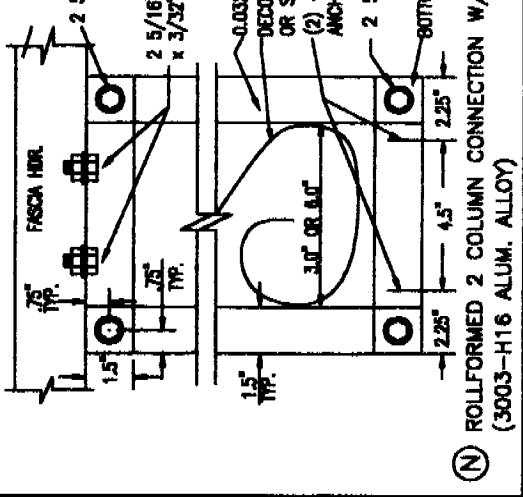
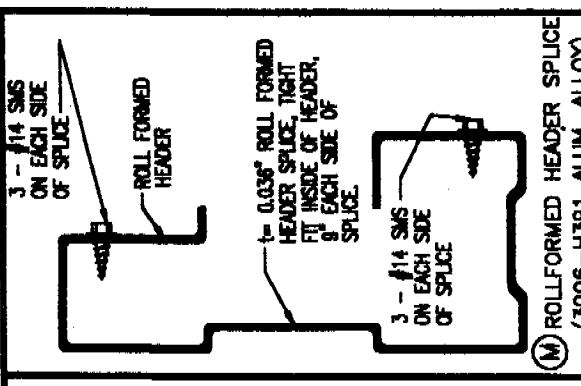
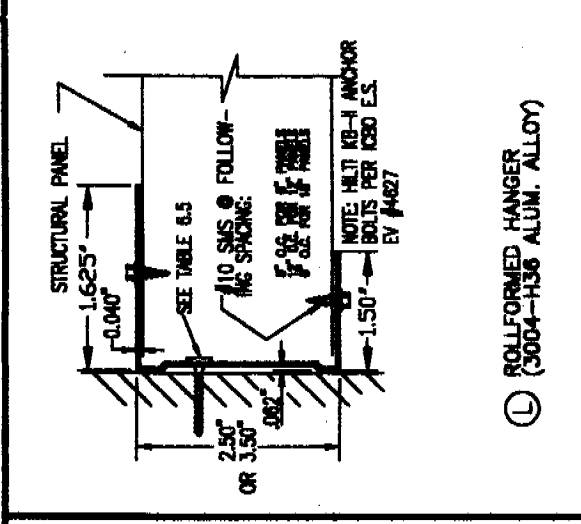
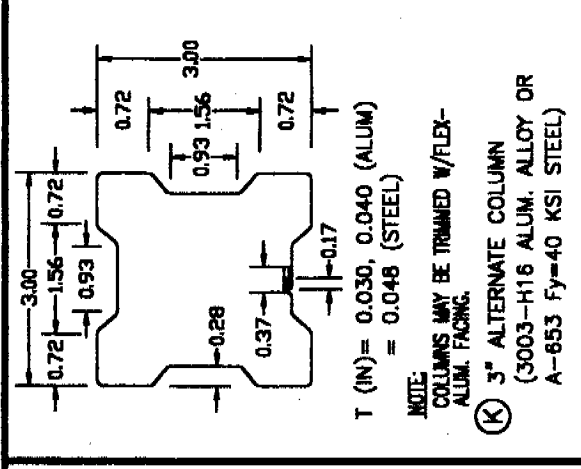
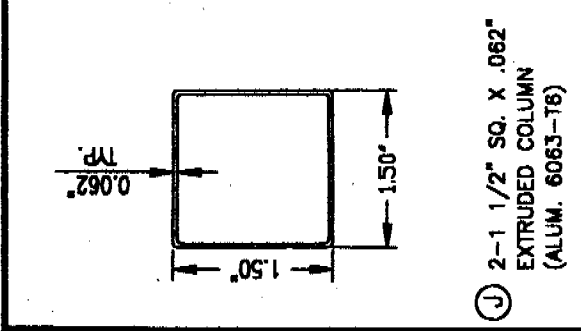
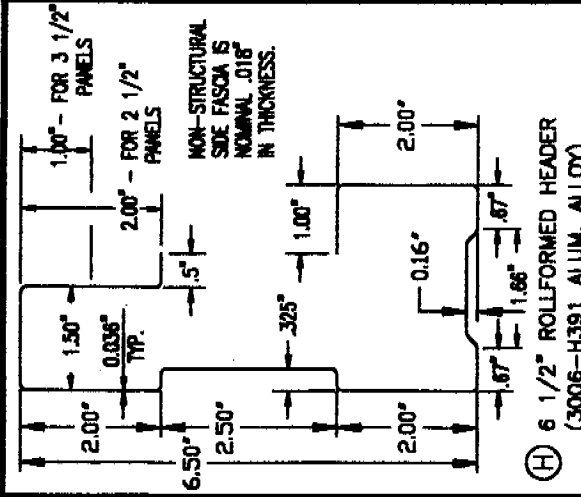

REGISTERED PROFESSIONAL ENGINEER
FREDRICK T. KATAKURA
No. 16273
Exp. 6-30-05
STATE OF CALIFORNIA

REGISTERED PROFESSIONAL ENGINEER
R. F. WICKER
NO. 26670
Exp. 11-31-02
STATE OF CALIFORNIA

APR 18 2000

DATE	REVISION	DATE	REVISION
2/8/2000			

Amertimax BUILDING PRODUCTS, INC.
Engineering Services
1140 All Pro Drive
Ellettsport, IN 46814

SCALE: NONE
DATE: 2/8/2000
SHEET: 2 OF 9

IC80 ES EVALUATION REPORT NO. ER-2621P
PART COMPONENT PARTS & CONNECTION DETAILS
97CD02

6.0 COLUMN AND FASTENER REQUIREMENTS FOR COMMERCIAL AND PATIO STRUCTURES

Column Spacing multiplied by Trib Width Lattice Tributary Area (sq ft)	Minimum Column Required for Attached Structures Live Load (psf)									
	10	20	25	30	35	40	45	50	55	60
23	A1	A1	A1	A1	A1	A2	C	C	C	C
31	A1	A1	A1	A1	A2	C	C	C	C	C
37	A1	A1	A1	A2	B	C	C	C	C	C
44	A1	A1	A2	B	C	C	C	C	C	C
56	A1	B	C	C	C	C	C	C	C	C
62	A1	C	C	C	C	C	C	C	C	C
69	A1	C	C	C	C	C	C	C	C	C
77	A1	C	C	C	C	C	C	C	C	C
86	A2	C	C	C	C	C	C	C	C	C
92	A2	C	C	C	C	C	C	C	C	C
100	A2	C	C	C	C	C	C	C	C	C
106	B	C	C	C	C	C	C	C	C	C
108	C	C	C	C	C	C	C	C	C	C
116	C	C	C	C	C	C	C	C	C	C
123	C	C	C	C	C	C	C	C	C	C
138	C	C	C	C	C	C	C	C	C	C
154	C	C	C	C	C	C	C	C	C	C
188	C	C	C	C	C	C	C	C	C	C
216	D	E	E	E	E	F	F	F	F	F
248	D	E	E	E	E	F	F	F	F	F
277	D	E	E	E	E	F	F	F	F	F
308	D	E	E	E	E	F	F	F	F	F
338	E	E	E	E	E	F	F	F	F	F
385	E	E	E	E	E	F	F	F	F	F
482	E	E	E	E	E	F	F	F	F	F
616	E	E	E	E	E	F	F	F	F	F
688	E	E	E	E	E	F	F	F	F	F
789	F	F	F	F	F	G	G	G	G	G
923	F	F	F	F	F	G	G	G	G	G

Table 6.1

COLUMN TYPE	COLUMN DESCRIPTIONS	DETAIL	MAX COL HEIGHT
A1	0.024" x 3" SQUARE ALUM COLUMN	F	10'-0"
A2	0.024" x 3" SQUARE ALUM COLUMN	F	8'-0"
B	0.032" x 1 1/2" SQUARE ALUM SCROLL COLUMN	E, N	8'-0"
B	0.027" x 3" SQUARE ALUM COLUMN	F	11'-4"
C	3" CLOVERLEAF ALUM. 0.047"	K	12'-0"
D	FLUTED COLUMN ALUM. 0.082"	U	12'-0"
E	3" CLOVERLEAF STEEL 0.048"	K	8'-7"
F	3" SQUARE STEEL COLUMN	X	18'-0"
G	4" SQUARE STEEL COLUMN	X	18'-0"
H	5" SQUARE STEEL COLUMN	X	18'-0"
J	6" SQUARE STEEL COLUMN	X	18'-0"

Table 6.2

Table 6.3: Required Number of Fasteners for Shearing Loads

Footer Size d (in)	Aluminum Material Gauge (in)									
	A	B	C	D	E	F	G	H	I	J
12	1	1	1	1	1	1	1	1	1	1
13	1	1	1	1	1	1	1	1	1	1
14	1	1	1	1	1	1	1	1	1	1
15	1	1	1	1	1	1	1	1	1	1
16	2	2	2	2	2	2	2	2	2	2
17	2	2	2	2	2	2	2	2	2	2
18	2	2	2	2	2	2	2	2	2	2
19	3	3	3	3	3	3	3	3	3	3
20	3	3	3	3	3	3	3	3	3	3
21	4	4	4	4	4	4	4	4	4	4
22	4	4	4	4	4	4	4	4	4	4
23	5	5	5	5	5	5	5	5	5	5
24	5	5	5	5	5	5	5	5	5	5
25	6	6	6	6	6	6	6	6	6	6
26	6	6	6	6	6	6	6	6	6	6
27	6	6	6	6	6	6	6	6	6	6
28	6	6	6	6	6	6	6	6	6	6
29	6	6	6	6	6	6	6	6	6	6
30	6	6	6	6	6	6	6	6	6	6
31	6	6	6	6	6	6	6	6	6	6
32	6	6	6	6	6	6	6	6	6	6
33	6	6	6	6	6	6	6	6	6	6
34	6	6	6	6	6	6	6	6	6	6
35	6	6	6	6	6	6	6	6	6	6
36	6	6	6	6	6	6	6	6	6	6
37	6	6	6	6	6	6	6	6	6	6
38	6	6	6	6	6	6	6	6	6	6
39	6	6	6	6	6	6	6	6	6	6
40	6	6	6	6	6	6	6	6	6	6
41	6	6	6	6	6	6	6	6	6	6
42	6	6	6	6	6	6	6	6	6	6
43	6	6	6	6	6	6	6	6	6	6
44	6	6	6	6	6	6	6	6	6	6
45	6	6	6	6	6	6	6	6	6	6
46	6	6	6	6	6	6	6	6	6	6
47	6	6	6	6	6	6	6	6	6	6
48	6	6	6	6	6	6	6	6	6	6
49	6	6	6	6	6	6	6	6	6	6
50	6	6	6	6	6	6	6	6	6	6

Table 6.4: Required Number of Fasteners for Tension Loads

Footer Size d (in)	Aluminum Gauge (in)									
	K	L	M	N	O	P	Q	R	S	T
12	1	1	1	1	1	1	1	1	1	1
13	1	1	1	1	1	1	1	1	1	1
14	1	1	1	1	1	1	1	1	1	1
15	1	1	1	1	1	1	1	1	1	1
16	1	1	1	1	1	1	1	1	1	1
17	1	1	1	1	1	1	1	1	1	1
18	1	1	1	1	1	1	1	1	1	1
19	1	1	1	1	1	1	1	1	1	1
20	1	1	1	1	1	1	1	1	1	1
21	1	1	1	1	1	1	1	1	1	1
22	1	1	1	1	1	1	1	1	1	1
23	1	1	1	1	1	1	1	1	1	1
24	1	1	1	1	1	1	1	1	1	1
25	1	1	1	1	1	1	1	1	1	1
26	1	1	1	1	1	1	1	1	1	1
27	1	1	1	1	1	1	1	1	1	1
28	1	1	1	1	1	1	1	1	1	1
29	1	1	1	1	1	1	1	1	1	1
30	1	1	1	1	1	1	1	1	1	1
31	1	1	1	1	1	1	1	1	1	1
32	1	1	1	1	1	1	1	1	1	1
33	1	1	1	1	1	1	1	1	1	1
34	1	1	1	1	1	1	1	1	1	1
35	1	1	1	1	1	1	1	1	1	1
36	1	1	1	1	1	1	1	1	1	1
37	1	1	1	1	1	1	1	1	1	1
38	1	1	1	1	1	1	1	1	1	1
39	1	1	1	1	1	1	1	1	1	1
40	1	1	1	1	1	1	1	1	1	1
41	1	1	1	1	1	1	1	1	1	1
42	1	1	1	1	1	1	1	1	1	1
43	1	1	1	1	1	1	1	1	1	1
44	1	1	1	1	1	1	1	1	1	1
45	1	1	1	1	1	1	1	1	1	1
46	1	1	1	1	1	1	1	1	1	1
47	1	1	1	1	1	1	1	1	1	1
48	1	1	1	1	1	1	1	1	1	1
49	1	1	1	1	1	1	1	1	1	1
50	1	1	1	1	1	1	1	1	1	1

- Spacing between bolts and screws shall be 2.5 times the shank diameter
- The edge distance of bolts and screws shall be 3 times the shank diameter
- Connections shall be arranged so that the center of resistance of the connection shall coincide with the resultant line of action of the load.

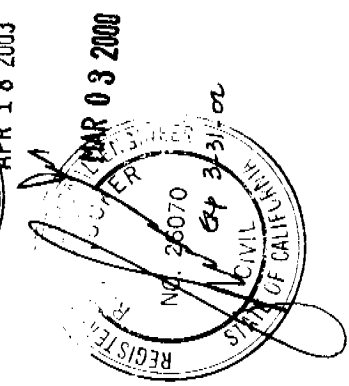
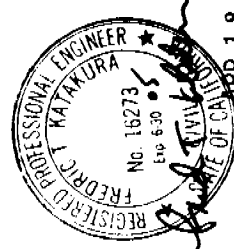

Amerimax
BUILDING PRODUCTS, INC.
 1140 ALL PRO DRIVE
 ELKHART, IN 46514
 ICBO E5 EVALUATION REPORT EP-2651P
 COLUMN AND FASTENER TABLES
 SHEET 8 OF 8 DATE: 2/8/2000

TABLE 6.5: WALL ATTACHMENTS FOR PATIO AND COM. STRUCTURES

LIVE LOAD (PSF)	ANC 1		ANC 2		ANC 3		ANC 4	
	O/C	SPACING	O/C	SPACING	O/C	SPACING	O/C	SPACING
10	24"	24"	24"	16"	16"	16"	22"	1
20	24"	16"	16"	8"	8"	8"	11"	1
25	24"	15"	15"	8"	8"	8"	11"	2
30	24"	14"	14"	8"	8"	8"	10"	2
40	24"	12"	12"	8"	8"	8"	13"	2
60	16"	10"	10"	4"	4"	4"	11"	2

- Fastener Terminology
 #14 SMS = #14 sheet metal or Tek screw, 3/4" minimum length
 5/16" B = 5/16" Diameter Bolt
 See General Notes for specifics on fasteners
- Cleanspan on this chart is the distance from the well to the first row of columns.
 - Hill Kwik Bolt 1/4" diameter and 2" embedment: ICBO ER-4627 or other anchor w/ 5500# shear vs wind and seismic loads.
 - Masonry anchors must have a shear value of 2500# for wind or seismic loads.
 - 1/4" Lag screws must have 2 1/4" of penetration into studs. These lag screws must have an 1/8" lead hole.
 - 10 perf evaluated at 90 mph wind load (15 psf). All other loads evaluated at 90 mph exposure C.

4.0 FREESTANDING AND ATTACHED LATTICE PATIO STRUCTURES

LIVE LOAD (PSF)	TRIB WIDTH (FT)	MAXIMUM COLUMN SPACING				MAXIMUM COLUMN SPACING				0.036 x 3' x 8' BOX BEAM				0.042 x 3' x 8' BOX BEAM				DOUBLE 0.037 x 7' x 8'			
		FOR ATTACHED LATTICE ON SPAN	FOR ATTACHED LATTICE ON SPAN	FOR ATTACHED LATTICE ON SPAN	FOR ATTACHED LATTICE ON SPAN	FOR ATTACHED LATTICE ON SPAN	FOR ATTACHED LATTICE ON SPAN	FOR ATTACHED LATTICE ON SPAN	FOR ATTACHED LATTICE ON SPAN	FOR ATTACHED LATTICE ON SPAN	FOR ATTACHED LATTICE ON SPAN	FOR ATTACHED LATTICE ON SPAN	FOR ATTACHED LATTICE ON SPAN	FOR ATTACHED LATTICE ON SPAN	FOR ATTACHED LATTICE ON SPAN	FOR ATTACHED LATTICE ON SPAN	FOR ATTACHED LATTICE ON SPAN	FOR ATTACHED LATTICE ON SPAN	FOR ATTACHED LATTICE ON SPAN	FOR ATTACHED LATTICE ON SPAN	
10	4	21'-1"	22'-0"	25'-7"	25'-7"	5'-0"	5'-0"	5'-0"	5'-0"	11'-2"	11'-2"	17'-4"	17'-4"	17'-4"	17'-4"	15'-9"	15'-9"	15'-9"	15'-9"	15'-9"	15'-9"
10	5	18'-10"	17'-7"	20'-5"	20'-5"	4'-8"	4'-8"	4'-8"	4'-8"	8'-11"	8'-11"	14'-3"	14'-3"	14'-3"	14'-3"	12'-11"	12'-11"	12'-11"	12'-11"	12'-11"	12'-11"
10	6	14'-1"	14'-1"	17'-0"	17'-0"	4'-8"	4'-8"	4'-8"	4'-8"	7'-5"	7'-5"	11'-11"	11'-11"	11'-11"	11'-11"	10'-4"	10'-4"	10'-4"	10'-4"	10'-4"	10'-4"
10	7	12'-1"	12'-1"	14'-7"	14'-7"	4'-8"	4'-8"	4'-8"	4'-8"	6'-4"	6'-4"	10'-2"	10'-2"	10'-2"	10'-2"	9'-4"	9'-4"	9'-4"	9'-4"	9'-4"	9'-4"
10	8	10'-7"	10'-7"	12'-9"	12'-9"	4'-8"	4'-8"	4'-8"	4'-8"	5'-7"	5'-7"	9'-11"	9'-11"	9'-11"	9'-11"	8'-8"	8'-8"	8'-8"	8'-8"	8'-8"	8'-8"
10	9	9'-4"	9'-4"	11'-4"	11'-4"	4'-8"	4'-8"	4'-8"	4'-8"	5'-7"	5'-7"	8'-11"	8'-11"	8'-11"	8'-11"	7'-5"	7'-5"	7'-5"	7'-5"	7'-5"	7'-5"
10	10	8'-5"	8'-5"	10'-3"	10'-3"	4'-8"	4'-8"	4'-8"	4'-8"	4'-8"	4'-8"	7'-5"	7'-5"	7'-5"	7'-5"	6'-10"	6'-10"	6'-10"	6'-10"	6'-10"	6'-10"
10	11	7'-8"	7'-8"	9'-4"	9'-4"	4'-8"	4'-8"	4'-8"	4'-8"	4'-8"	4'-8"	6'-4"	6'-4"	6'-4"	6'-4"	5'-7"	5'-7"	5'-7"	5'-7"	5'-7"	5'-7"
10	12	7'-0"	7'-0"	8'-4"	8'-4"	4'-8"	4'-8"	4'-8"	4'-8"	4'-8"	4'-8"	5'-7"	5'-7"	5'-7"	5'-7"	5'-7"	5'-7"	5'-7"	5'-7"	5'-7"	5'-7"
10	13	6'-4"	6'-4"	7'-4"	7'-4"	4'-8"	4'-8"	4'-8"	4'-8"	4'-8"	4'-8"	4'-8"	4'-8"	4'-8"	4'-8"	4'-8"	4'-8"	4'-8"	4'-8"	4'-8"	4'-8"
10	14	6'-0"	6'-0"	7'-0"	7'-0"	4'-8"	4'-8"	4'-8"	4'-8"	4'-8"	4'-8"	4'-8"	4'-8"	4'-8"	4'-8"	4'-8"	4'-8"	4'-8"	4'-8"	4'-8"	4'-8"
10	15	5'-7"	5'-7"	6'-4"	6'-4"	4'-8"	4'-8"	4'-8"	4'-8"	4'-8"	4'-8"	4'-8"	4'-8"	4'-8"	4'-8"	4'-8"	4'-8"	4'-8"	4'-8"	4'-8"	4'-8"
10	16	5'-3"	5'-3"	6'-0"	6'-0"	4'-8"	4'-8"	4'-8"	4'-8"	4'-8"	4'-8"	4'-8"	4'-8"	4'-8"	4'-8"	4'-8"	4'-8"	4'-8"	4'-8"	4'-8"	4'-8"
10	17	5'-0"	5'-0"	5'-7"	5'-7"	4'-8"	4'-8"	4'-8"	4'-8"	4'-8"	4'-8"	4'-8"	4'-8"	4'-8"	4'-8"	4'-8"	4'-8"	4'-8"	4'-8"	4'-8"	4'-8"
10	18	4'-8"	4'-8"	5'-3"	5'-3"	4'-8"	4'-8"	4'-8"	4'-8"	4'-8"	4'-8"	4'-8"	4'-8"	4'-8"	4'-8"	4'-8"	4'-8"	4'-8"	4'-8"	4'-8"	4'-8"
10	19	4'-5"	4'-5"	5'-0"	5'-0"	4'-8"	4'-8"	4'-8"	4'-8"	4'-8"	4'-8"	4'-8"	4'-8"	4'-8"	4'-8"	4'-8"	4'-8"	4'-8"	4'-8"	4'-8"	4'-8"
10	20	4'-2"	4'-2"	4'-7"	4'-7"	4'-8"	4'-8"	4'-8"	4'-8"	4'-8"	4'-8"	4'-8"	4'-8"	4'-8"	4'-8"	4'-8"	4'-8"	4'-8"	4'-8"	4'-8"	4'-8"
10	21	4'-0"	4'-0"	4'-4"	4'-4"	4'-8"	4'-8"	4'-8"	4'-8"	4'-8"	4'-8"	4'-8"	4'-8"	4'-8"	4'-8"	4'-8"	4'-8"	4'-8"	4'-8"	4'-8"	4'-8"
10	22	3'-8"	3'-8"	4'-1"	4'-1"	4'-8"	4'-8"	4'-8"	4'-8"	4'-8"	4'-8"	4'-8"	4'-8"	4'-8"	4'-8"	4'-8"	4'-8"	4'-8"	4'-8"	4'-8"	4'-8"

A* = 8' MAXIMUM COLUMN LENGTH
A** = 10' MAXIMUM COLUMN LENGTH

MAR 03 2000

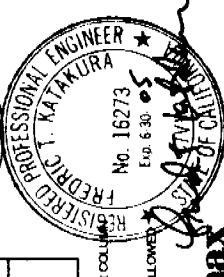
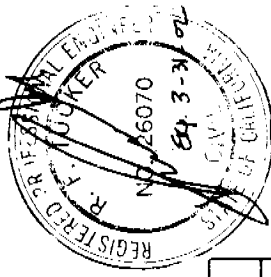

APR 18 2003



ICBO'S EVALUATION REPORT: ER-2821P
HEADER SPANS, COLUMN SPACING,
FOOTER SIZE AND COLUMN TYPE FOR
WIND-RESISTANT LATTICE PATIO STRUCTURES
SHEET 6 OF 6 DATE: 2/9/2000

TABLE 4.2

LIVE LOAD (PSF)	TRIB WIDTH (FT)	CLEAR SPANS FOR 2 X 4 BARTER		CLEAR SPANS FOR 2 X 6 BARTER	
		OVER HANG	OVER HANG	OVER HANG	OVER HANG
10	4	13'-7"	13'-7"	13'-7"	13'-7"
10	5	13'-7"	13'-7"	13'-7"	13'-7"
10	6	13'-7"	13'-7"	13'-7"	13'-7"
10	7	13'-7"	13'-7"	13'-7"	13'-7"
10	8	13'-7"	13'-7"	13'-7"	13'-7"
10	9	13'-7"	13'-7"	13'-7"	13'-7"
10	10	13'-7"	13'-7"	13'-7"	13'-7"
10	11	13'-7"	13'-7"	13'-7"	13'-7"
10	12	13'-7"	13'-7"	13'-7"	13'-7"
10	13	13'-7"	13'-7"	13'-7"	13'-7"
10	14	13'-7"	13'-7"	13'-7"	13'-7"
10	15	13'-7"	13'-7"	13'-7"	13'-7"
10	16	13'-7"	13'-7"	13'-7"	13'-7"
10	17	13'-7"	13'-7"	13'-7"	13'-7"
10	18	13'-7"	13'-7"	13'-7"	13'-7"
10	19	13'-7"	13'-7"	13'-7"	13'-7"
10	20	13'-7"	13'-7"	13'-7"	13'-7"
10	21	13'-7"	13'-7"	13'-7"	13'-7"
10	22	13'-7"	13'-7"	13'-7"	13'-7"

TABLE 4.3

LIVE LOAD (PSF)	TRIB WIDTH (FT)	CLEAR SPANS FOR 2 X 4 BARTER		CLEAR SPANS FOR 2 X 6 BARTER	
		OVER HANG	OVER HANG	OVER HANG	OVER HANG
25	4	11'-11"	11'-11"	11'-11"	11'-11"
25	5	11'-11"	11'-11"	11'-11"	11'-11"
25	6	11'-11"	11'-11"	11'-11"	11'-11"
25	7	11'-11"	11'-11"	11'-11"	11'-11"
25	8	11'-11"	11'-11"	11'-11"	11'-11"
25	9	11'-11"	11'-11"	11'-11"	11'-11"
25	10	11'-11"	11'-11"	11'-11"	11'-11"
25	11	11'-11"	11'-11"	11'-11"	11'-11"
25	12	11'-11"	11'-11"	11'-11"	11'-11"
25	13	11'-11"	11'-11"	11'-11"	11'-11"
25	14	11'-11"	11'-11"	11'-11"	11'-11"
25	15	11'-11"	11'-11"	11'-11"	11'-11"
25	16	11'-11"	11'-11"	11'-11"	11'-11"
25	17	11'-11"	11'-11"	11'-11"	11'-11"
25	18	11'-11"	11'-11"	11'-11"	11'-11"
25	19	11'-11"	11'-11"	11'-11"	11'-11"
25	20	11'-11"	11'-11"	11'-11"	11'-11"
25	21	11'-11"	11'-11"	11'-11"	11'-11"
25	22	11'-11"	11'-11"	11'-11"	11'-11"

TABLE 4.4

LIVE LOAD (PSF)	TRIB WIDTH (FT)	CLEAR SPANS FOR 2 X 4 BARTER		CLEAR SPANS FOR 2 X 6 BARTER	
		OVER HANG	OVER HANG	OVER HANG	OVER HANG
30	4	10'-8"	10'-8"	10'-8"	10'-8"
30	5	10'-8"	10'-8"	10'-8"	10'-8"
30	6	10'-8"	10'-8"	10'-8"	10'-8"
30	7	10'-8"	10'-8"	10'-8"	10'-8"
30	8	10'-8"	10'-8"	10'-8"	10'-8"
30	9	10'-8"	10'-8"	10'-8"	10'-8"
30	10	10'-8"	10'-8"	10'-8"	10'-8"
30	11	10'-8"	10'-8"	10'-8"	10'-8"
30	12	10'-8"	10'-8"	10'-8"	10'-8"
30	13	10'-8"	10'-8"	10'-8"	10'-8"
30	14	10'-8"	10'-8"	10'-8"	10'-8"
30	15	10'-8"	10'-8"	10'-8"	10'-8"
30	16	10'-8"	10'-8"	10'-8"	10'-8"
30	17	10'-8"	10'-8"	10'-8"	10'-8"
30	18	10'-8"	10'-8"	10'-8"	10'-8"
30	19	10'-8"	10'-8"	10'-8"	10'-8"
30	20	10'-8"	10'-8"	10'-8"	10'-8"
30	21	10'-8"	10'-8"	10'-8"	10'-8"
30	22	10'-8"	10'-8"	10'-8"	10'-8"

TABLE 4.5

LIVE LOAD (PSF)	TRIB WIDTH (FT)	CLEAR SPANS FOR 2 X 4 BARTER		CLEAR SPANS FOR 2 X 6 BARTER	
		OVER HANG	OVER HANG	OVER HANG	OVER HANG
40	4	8'-4"	8'-4"	8'-4"	8'-4"
40	5	8'-4"	8'-4"	8'-4"	8'-4"
40	6	8'-4"	8'-4"	8'-4"	8'-4"
40	7	8'-4"	8'-4"	8'-4"	8'-4"
40	8	8'-4"	8'-4"	8'-4"	8'-4"
40	9	8'-4"	8'-4"	8'-4"	8'-4"
40	10	8'-4"	8'-4"	8'-4"	8'-4"
40	11	8'-4"	8'-4"	8'-4"	8'-4"
40	12	8'-4"	8'-4"	8'-4"	8'-4"
40	13	8'-4"	8'-4"	8'-4"	8'-4"
40	14	8'-4"	8'-4"	8'-4"	8'-4"
40	15	8'-4"	8'-4"	8'-4"	8'-4"
40	16	8'-4"	8'-4"	8'-4"	8'-4"
40	17	8'-4"	8'-4"	8'-4"	8'-4"
40	18	8'-4"	8'-4"	8'-4"	8'-4"
40	19	8'-4"	8'-4"	8'-4"	8'-4"
40	20	8'-4"	8'-4"	8'-4"	8'-4"
40	21	8'-4"	8'-4"	8'-4"	8'-4"
40	22	8'-4"	8'-4"	8'-4"	8'-4"

FOR 10 PSF DOUBLE PARTERS MAY BE USED 48" O.C.

FOR 10 PSF DOUBLE PARTERS MAY BE USED 48" O.C.

FOR 10 PSF DOUBLE PARTERS MAY BE USED 48" O.C.

FOR 10 PSF DOUBLE PARTERS MAY BE USED 48" O.C.

COLUMN SCHEDULE FOR FREESTANDING STRUCTURES AND INTERMEDIATE COLUMNS FOR MULTISPAN STRUCTURES	
COLUMN	NOTES
E	6" MAX COLUMN LENGTH
F	11" MAX COLUMN LENGTH
G	12" MAX COLUMN LENGTH
H	12" MAX COLUMN LENGTH

COLUMN SCHEDULE FOR ATTACHED LATTICE PATIO STRUCTURES	
COL	MAX COLUMN HEIGHT
A	11'-5"
B	8'-0"
C	11'-4"
D	12'-0"
E	12'-0"
F	12'-0"
G	12'-0"
H	12'-0"
I	12'-0"
J	12'-0"

ALL COLUMNS MAY BE REPLACED WITH A STRONGER COLUMN
K MAY BE REPLACED WITH B.U.
L MAY BE REPLACED WITH C.I. ETC.
LINEAR INTERPOLATION FOR ALL CALCULATIONS IS ALLOWED

ALL COLUMNS MAY BE REPLACED WITH A STRONGER COLUMN
K MAY BE REPLACED WITH B.U.
L MAY BE REPLACED WITH C.I. ETC.
LINEAR INTERPOLATION FOR ALL CALCULATIONS IS ALLOWED

ALL COLUMNS MAY BE REPLACED WITH A STRONGER COLUMN
K MAY BE REPLACED WITH B.U.
L MAY BE REPLACED WITH C.I. ETC.
LINEAR INTERPOLATION FOR ALL CALCULATIONS IS ALLOWED

ALL COLUMNS MAY BE REPLACED WITH A STRONGER COLUMN
K MAY BE REPLACED WITH B.U.
L MAY BE REPLACED WITH C.I. ETC.
LINEAR INTERPOLATION FOR ALL CALCULATIONS IS ALLOWED

3.0 FREESTANDING AND ATTACHED COMMERCIAL STRUCTURES

LIVE LOAD (PSF)	TRUSS WIDTH (FT)	5" I BEAM				7" I BEAM				10" I BEAM				12" I BEAM				TRUSS WIDTH (FT)															
		MAX. COLUMN SPACING (FT)	MAX. COLUMN SPACING (FT)	MAX. COLUMN SPACING (FT)	MAX. COLUMN SPACING (FT)	MAX. COLUMN SPACING (FT)	MAX. COLUMN SPACING (FT)	MAX. COLUMN SPACING (FT)	MAX. COLUMN SPACING (FT)	MAX. COLUMN SPACING (FT)	MAX. COLUMN SPACING (FT)	MAX. COLUMN SPACING (FT)	MAX. COLUMN SPACING (FT)	MAX. COLUMN SPACING (FT)	MAX. COLUMN SPACING (FT)	MAX. COLUMN SPACING (FT)																	
20	4	24-5	26	28	30	31	33	26	29-0	27	29	31	33	28	40-11	29	31	33	35	29	4	5	6	7	8	9	10	11	12	13	14	15	16
	5	22-6	24	26	28	30	31	32	27	28	30	31	32	27	37-11	28	30	31	32	28	5	6	7	8	9	10	11	12	13	14	15	16	
	6	20-11	22	24	26	28	29	31	28	29-4	28	30	31	32	36-9	27	29	30	31	28	6	7	8	9	10	11	12	13	14	15	16		
	7	19-4	21	23	25	27	28	29	27	28-5	28	29	30	31	33-3	28	29	30	31	29	7	8	9	10	11	12	13	14	15	16	17	18	
	8	18-1	20	22	24	26	27	28	27	28-11	28	29	30	31	31-1	28	29	30	31	29	8	9	10	11	12	13	14	15	16	17	18	19	
	9	17-1	19	21	23	25	26	27	26	27-8	28	29	30	30	29-4	28	29	30	31	29	9	10	11	12	13	14	15	16	17	18	19	20	
	10	16-2	18	20	22	24	25	26	25	26-2	27	28	29	29	28-8	28	29	30	31	29	10	11	12	13	14	15	16	17	18	19	20	21	
	11	15-5	17	19	21	23	24	25	24	25-1	26	27	28	28	27-8	27	28	29	30	29	11	12	13	14	15	16	17	18	19	20	21	22	
	12	14-9	16	18	20	22	23	24	23	24-1	25	26	27	27	26-2	26	27	28	29	28	12	13	14	15	16	17	18	19	20	21	22	23	
	13	14-2	15	17	19	21	22	23	22	23-1	24	25	26	26	25-1	25	26	27	28	27	13	14	15	16	17	18	19	20	21	22	23	24	
	14	13-8	14	16	18	20	21	22	21	22-1	23	24	25	25	24-1	24	25	26	27	26	14	15	16	17	18	19	20	21	22	23	24	25	26
	15	13-2	13	15	17	19	20	21	20	21-1	22	23	24	24	23-1	23	24	25	26	25	15	16	17	18	19	20	21	22	23	24	25	26	27
	16	12-9	12	14	16	18	19	20	19	20-1	21	22	23	23	22-1	22	23	24	25	24	16	17	18	19	20	21	22	23	24	25	26	27	28
	20	11-2	11	13	15	17	18	19	18	19-1	20	21	22	22	21-1	21	22	23	24	23	17	18	19	20	21	22	23	24	25	26	27	28	29

APR 18 2003

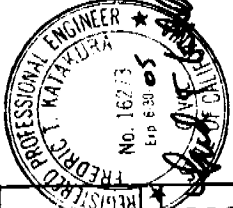

MAR 03 2000

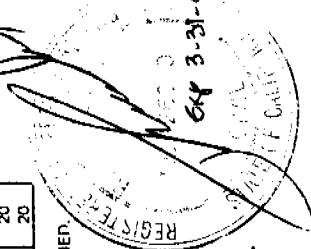

Amerimax
BUILDING PRODUCTS, INC.
ELKHART, IN 46514
DATE: 3/21/02

ICBO'S EVALUATION REPORT # E-2521P
HEADER SPANS, COLUMN SPACING,
FOOTER SIZE AND COLUMN TYPE FOR
FREESTANDING AND ATTACHED
STRUCTURES
SHEET 4 OF 8

ALL FOOTERS LISTED ARE CONSTRAINED.
TO USE NONCONSTRAINED FOOTERS
SEE TABLE ON SHEET 2 OF 8

TABLE 3.1

TABLE 3.2

TABLE 3.3

TABLE 3.4

TABLE 3.5

TABLE 3.6

TABLE 3.7

TABLE 3.8

TABLE 3.9

TABLE 3.10

TABLE 3.11

TABLE 3.12

TABLE 3.13

THIS PAGE LEFT INTENTIONALLY BLANK

MAR 03 2000

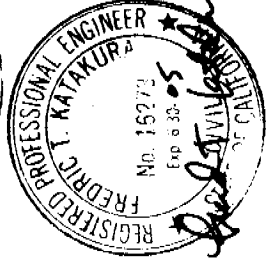
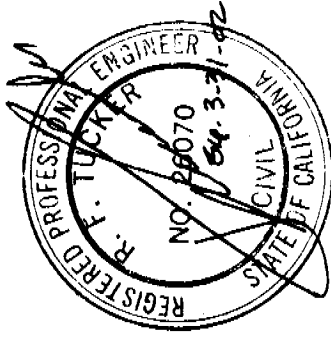

APR 18 2003



1140 ALL PRO DRIVE
ELKHART, IN 46514

ICBO ES EVALUATION REPORT ER-2821P

BLANK PAGE

DATE: 2/8/2000

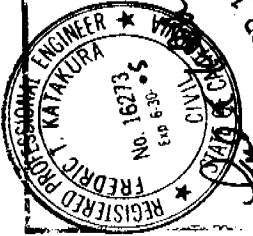

APR 18 2007
 SINGLE SPAN ATTACHED STRUCTURE

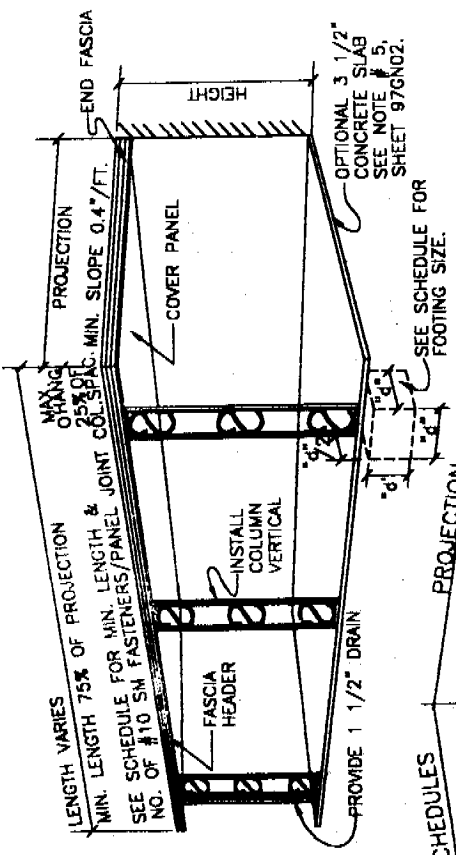

FOR COLUMN SPACING SEE TABLES 2.1, 2.5, 4.1 OR 4.2

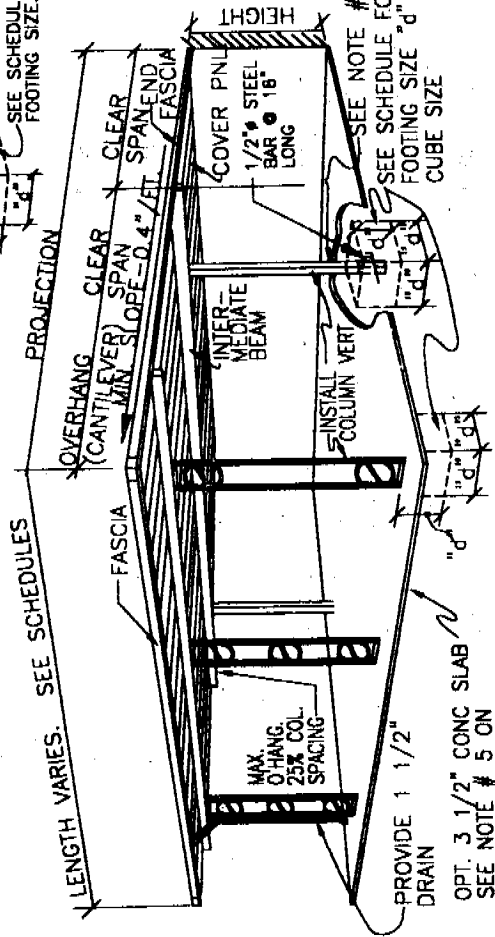

SEE NOTE #7, SHEET 97GN02.
 SEE SCHEDULE FOR FOOTING SIZE "d" = TYP. CUBE SIZE

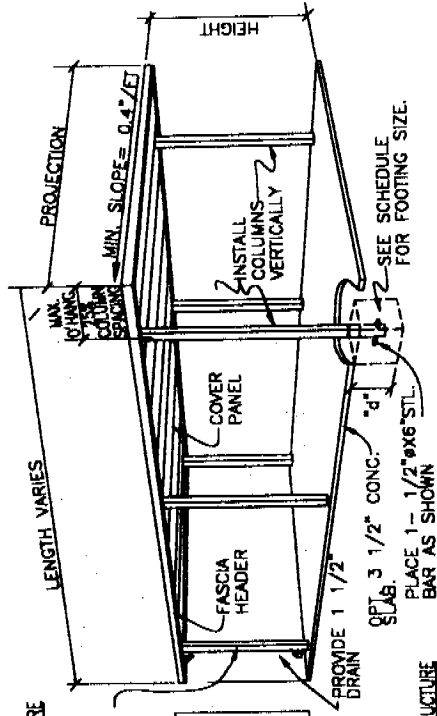

FOR COLUMN SIZE SEE "COLUMN SCHEDULE"

NOTE: PATIO WIDTH VARIES W/ SELECTION OF HEADER, NUMBER OF COLUMNS AND LOADING CONDITIONS. SEE SCHEDULES FOR MAX. COLUMN SPACING.

SINGLE SPAN FREESTANDING STRUCTURE

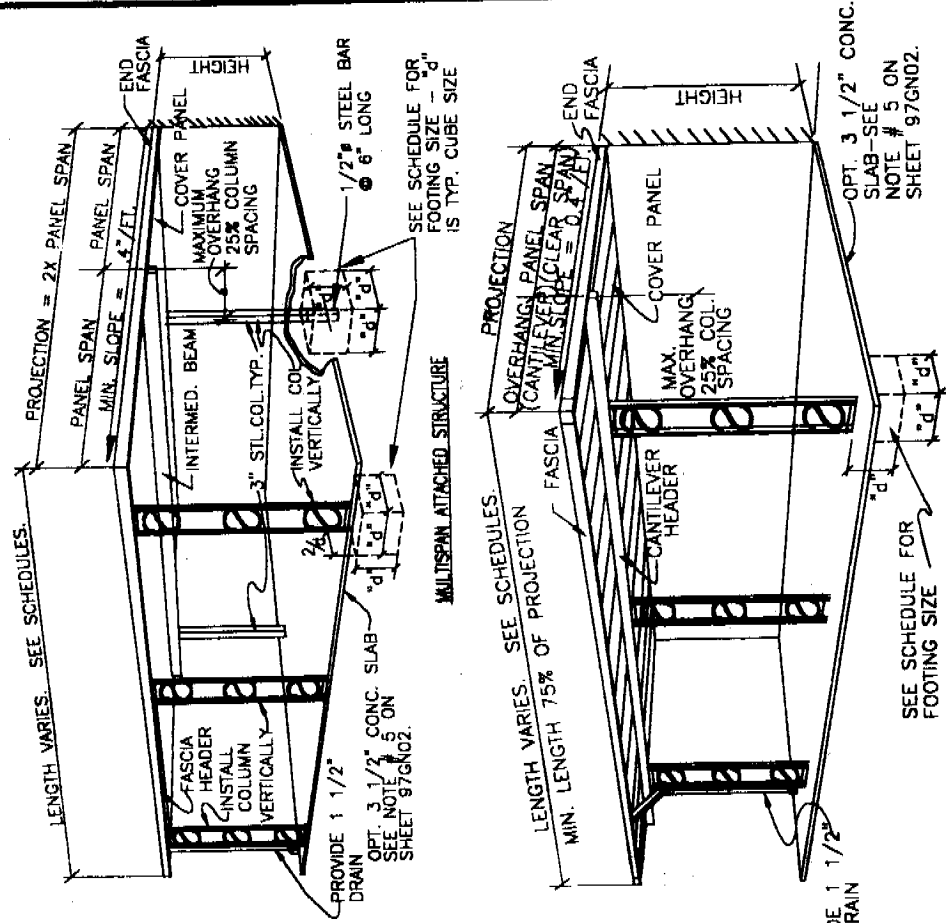

SEE SCHEDULE FOR FOOTING SIZE "d" IS TYP. CUBE SIZE

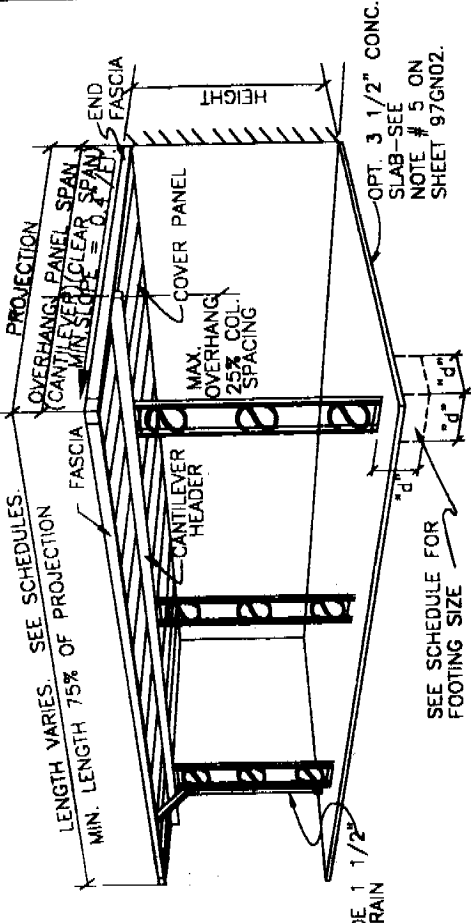

OPT. 3 1/2" CONC. SLAB - SEE NOTE # 5 ON SHEET 97GN02.

SINGLE SPAN ATTACHED CANTILEVERED STRUCTURE

DATE	REVISION	DATE	REVISION

REGISTERED PROFESSIONAL ENGINEER
 NO. 16273
 EXP. 6-30-05
 APR 03 2007
 MAR 03 2007
 EXP. 3-31-07
 ENGINEERS STAMP

Amerimax
 BUILDING PRODUCTS, INC.

Engineering Services
 1140 All Pro Drive
 Elkhart, IN 46514

DRAWN BY: KG
 CHECKED BY: NONE
 DATE: 2/8/2000
 PROJECT NO.: 97SC01
 SHEET: 1 OF 2

ICBO ES EVALUATION REPORT NO. ER-2621P
 DRAWING SCALE: STRUCTURAL CONFIGURATIONS

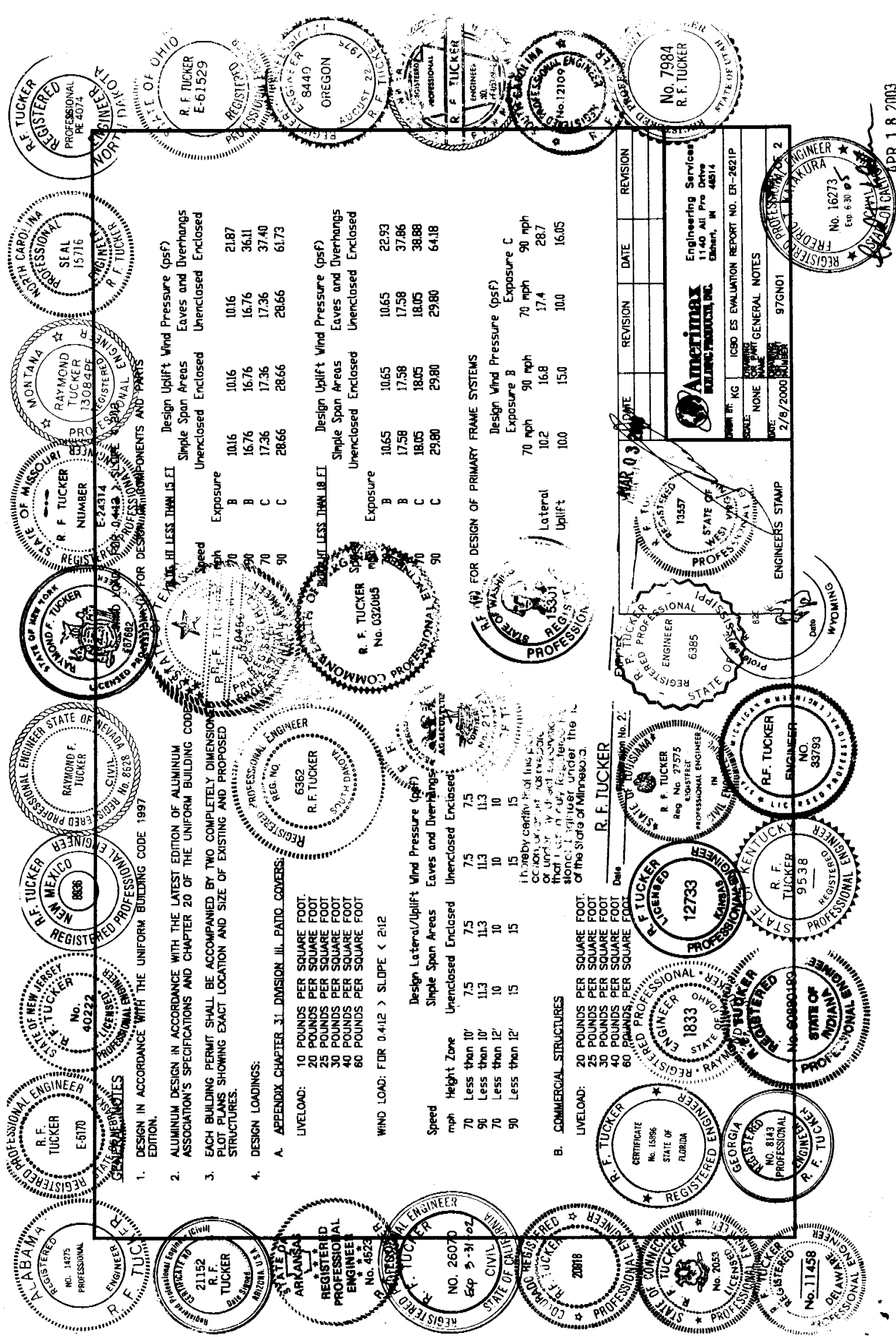

- DESIGN IN ACCORDANCE WITH THE UNIFORM BUILDING CODE 1997 EDITION.
- ALUMINUM DESIGN IN ACCORDANCE WITH THE LATEST EDITION OF ALUMINUM ASSOCIATION'S SPECIFICATIONS AND CHAPTER 20 OF THE UNIFORM BUILDING CODE.
- EACH BUILDING PERMIT SHALL BE ACCOMPANIED BY TWO COMPLETELY DIMENSIONED PLOT PLANS SHOWING EXACT LOCATION AND SIZE OF EXISTING AND PROPOSED STRUCTURES.
- DESIGN LOADINGS:
 - APPENDIX CHAPTER 31 DIVISION III, PARTO, COVERS:

LIVELOAD:	10 POUNDS PER SQUARE FOOT.
	20 POUNDS PER SQUARE FOOT
	25 POUNDS PER SQUARE FOOT
	30 POUNDS PER SQUARE FOOT
	40 POUNDS PER SQUARE FOOT
	60 POUNDS PER SQUARE FOOT

WIND LOAD: FOR 0.412 > SLOPE < 2:12

Speed mph	Height Zone	Design Lateral/Uplift Wind Pressure (psf)	
		Simple Span Areas	Eaves and Overhangs
70	Less than 10'	7.5	7.5
90	Less than 10'	11.3	11.3
70	Less than 12'	10	10
90	Less than 12'	15	15

Exposure	Design Uplift Wind Pressure (psf)	
	Simple Span Areas	Eaves and Overhangs
B	10.65	10.65
B	17.58	17.58
C	18.05	18.05
C	29.80	29.80

FOR DESIGN OF PRIMARY FRAME SYSTEMS

Exposure	Design Wind Pressure (psf)	
	Exposure B	Exposure C
70 mph	90 mph	90 mph
10.2	16.8	17.4
100	150	100
16.8	17.4	28.7
100	100	16.05

I hereby certify that this is a true and correct copy of the original as the same was filed in my office and that I am duly registered in the State of Minnesota.

R. F. TUCKER
No. 032085
REGISTERED PROFESSIONAL ENGINEER

AMERIMAX ENGINEERING SERVICES
1140 All Pro Drive
Elkhart, IN 46514

Engineering Services
1140 All Pro Drive
Elkhart, IN 46514

FORM NO. KG
SCALE: NONE
DATE: 2/8/2000

ICBO ES EVALUATION REPORT NO. ER-2621P
GENERAL NOTES
NUMBER: 97GN01

REVISION DATE REVISION DATE REVISION DATE

DATE: 03/03/00

ENGINEERS STAMP

REGISTERED PROFESSIONAL ENGINEER
R. F. TUCKER
No. 27575
STATE OF ILLINOIS

REGISTERED PROFESSIONAL ENGINEER
R. F. TUCKER
No. 12733
STATE OF KANSAS

REGISTERED PROFESSIONAL ENGINEER
R. F. TUCKER
No. 1833
STATE OF OHIO

REGISTERED PROFESSIONAL ENGINEER
R. F. TUCKER
No. 7984
STATE OF SOUTH CAROLINA

REGISTERED PROFESSIONAL ENGINEER
R. F. TUCKER
No. 16273
STATE OF TEXAS

REGISTERED PROFESSIONAL ENGINEER
R. F. TUCKER
No. 6385
STATE OF WISCONSIN

REGISTERED PROFESSIONAL ENGINEER
R. F. TUCKER
No. 9538
STATE OF KENTUCKY

REGISTERED PROFESSIONAL ENGINEER
R. F. TUCKER
No. 6080180
STATE OF INDIANA

REGISTERED PROFESSIONAL ENGINEER
R. F. TUCKER
No. 11458
STATE OF DELAWARE