

Sign Permit Application

2101 Arena Blvd. Ste.200 Sacramento CA 95834
 1231 I St. Ste.200 Sacramento CA 95814
 (916) 808-5656
 * Required Information



Inspection Line

(916) 808-7622 or 808-5716

Sign Permit # 0602327 Area 4

***Sign Address**

1889 ARDEN WAY, SPACE #2132, SACRAMENTO, CA

APN # <u>277-6160071</u>	Zone:	DR-PB / PUD / SC: <u>Arden ML</u>	P / ZA File:
--------------------------	-------	-----------------------------------	--------------

***Sign Applicant**

Property Owner \ License Contractor: <u>PRO AD SIGNS & LIGHTING</u>	
Address: <u>5961 W. OAKS BLVD, ROCKLIN</u>	Phone: <u>916 435-1055</u>
Contractor License # <u>857405</u>	Class <u>C-45</u>

***Sign Information**

Attached		Detached	
Bldg. Tenant Frontage	lineal. foot	Parcel Street Frontage	lineal. foot
	<u>22</u>		

Sign I.D. Tag	*Ht. x Wth.	= Sign Area	Sign Copy
<u>S060257</u>	<u>1.0' x 5'10 9/16"</u>	<u>5.88</u>	<u>SOLSTICE</u>
<u>S</u>			
<u>S</u>			
<u>S</u>			

Required Plan Review Approvals	Structural	Electrical	Design Review
--------------------------------	------------	------------	---------------

Code	Final Sign Inspection	Approved	Date
<u>99</u>	<u>FOOTING</u>		
<u>99</u>	<u>BUILDING</u>		
<u>98</u>	<u>ELECTRICAL</u>	<u>H-12-06 JBB</u>	
<u>n/a</u>	<u>SPECIAL INSPECTION</u>		

THIS SIGN PERMIT SHALL EXPIRE BY LIMITATION IF WORK AUTHORIZED IS NOT COMMENCED WITHIN 180 DAYS

CITY OF SACRAMENTO
 FEB 21 2006
 NEIGHBORHOODS PLANNING
 AND DEVELOPMENT SERVICES

Fees		\$100.00 per application.	
Total Sign Permit Fees : see Development Fee Schedule			
Cashier	Description	Date	Amount
	Sign Application Fee		
	Other		
	Balance		
Total	Sign Permit Fee		<u>144.18</u>

x [Signature] 2/21/06 Approved Sign Permit

CITY COPY

5060053

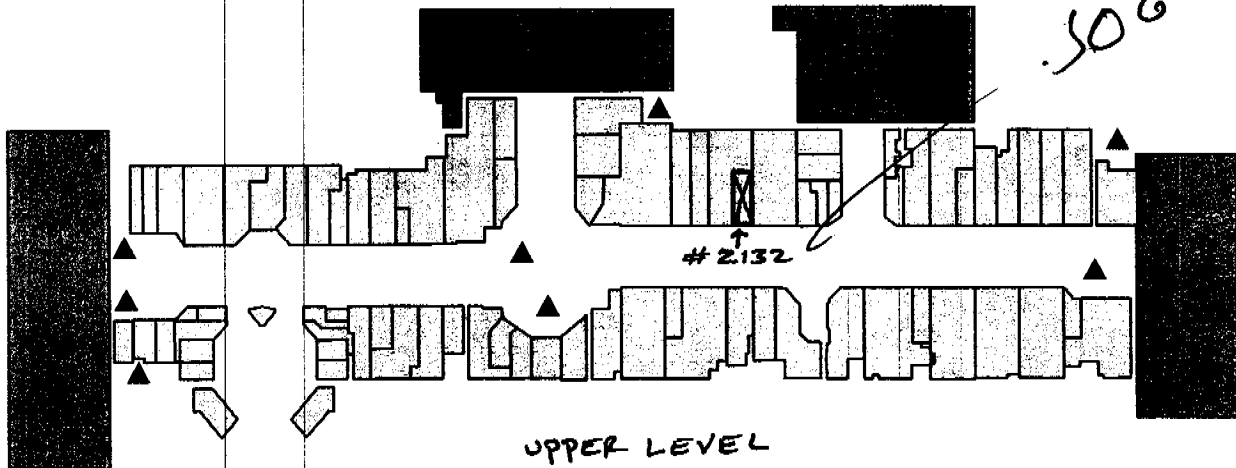

UPPER LEVEL

ARDEN FASH MALL
1689 ARDEN WALK

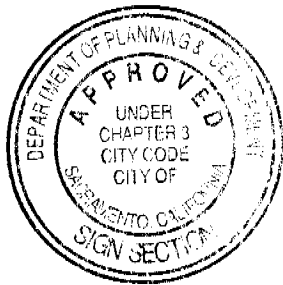

This set of plans and specifications must be kept on the job at all times and the contractor shall be responsible for making any and all corrections to the same with a written permit from the City of Sacramento. Such corrections shall not be made without the approval of the City Engineer. The approval of the City Engineer shall not be construed as a warranty or a violation of any law.

All electrical work must be U.L. labeled and conform to the standards, N.E.C. Sec. 90-6 and all other applicable codes, Div. 2 of The Sacramento City Code.

EQUIPMENT MUST BE USED AS SPECIFIED

ALL SIGN INSTALLATIONS ARE SUBJECT TO APPROVAL

CITY COPY

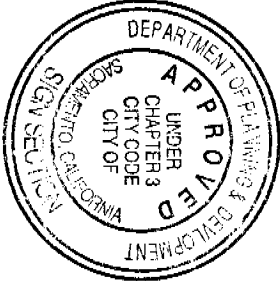
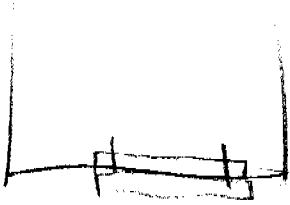

All electrical work must be U.L. listed and meet standards, N.E.C. Sec. 90-5, and all equipment must be listed and meet standards, N.E.C. Sec. 90-5, and all sign installations are subject to the same requirements as all other signs in the City of Sacramento.

EQUIPMENT MUST BE LISTED

ALL SIGN INSTALLATIONS ARE SUBJECT TO THE SAME REQUIREMENTS AS ALL OTHER SIGNS IN THE CITY OF SACRAMENTO.

This set of plans and specifications must be kept on the job site at all times and must be made available to the City of Sacramento for inspection at any time. The sign must be installed in accordance with the specifications and standards of the City of Sacramento.

1 ENLARGED PLAN AT STOREFRONT
SCALE 1/4" = 1'-0"

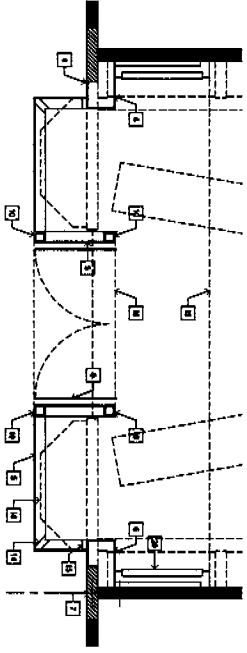

2 ELEVATION AT STOREFRONT
SCALE 1/4" = 1'-0"

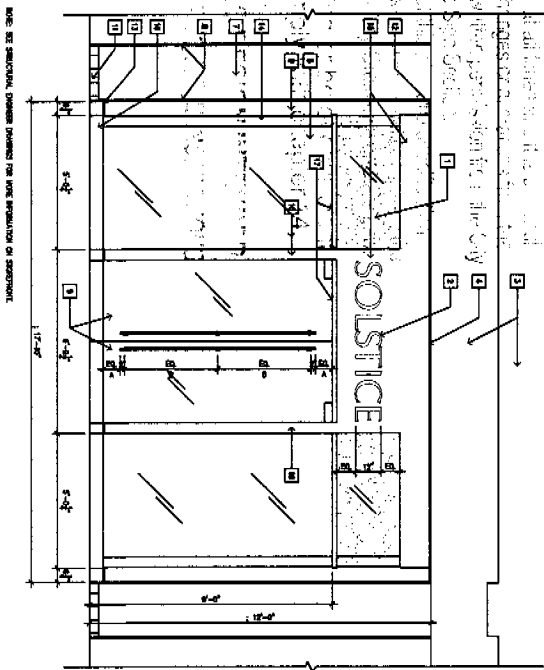

NOTE: SEE SIGNAGE CHANGES DRAWING FOR MORE INFORMATION ON SIGNAGE.

KEY NOTES

- 1. SIGN STRUCTURE SHALL BE 3/4" THICK ALUMINUM OR STEEL.
- 2. SIGN FACE SHALL BE 1/4" THICK ALUMINUM OR STEEL.
- 3. SIGN FACE SHALL BE 1/4" THICK ALUMINUM OR STEEL.
- 4. SIGN FACE SHALL BE 1/4" THICK ALUMINUM OR STEEL.
- 5. SIGN FACE SHALL BE 1/4" THICK ALUMINUM OR STEEL.
- 6. SIGN FACE SHALL BE 1/4" THICK ALUMINUM OR STEEL.
- 7. SIGN FACE SHALL BE 1/4" THICK ALUMINUM OR STEEL.
- 8. SIGN FACE SHALL BE 1/4" THICK ALUMINUM OR STEEL.
- 9. SIGN FACE SHALL BE 1/4" THICK ALUMINUM OR STEEL.
- 10. SIGN FACE SHALL BE 1/4" THICK ALUMINUM OR STEEL.
- 11. SIGN FACE SHALL BE 1/4" THICK ALUMINUM OR STEEL.
- 12. SIGN FACE SHALL BE 1/4" THICK ALUMINUM OR STEEL.
- 13. SIGN FACE SHALL BE 1/4" THICK ALUMINUM OR STEEL.
- 14. SIGN FACE SHALL BE 1/4" THICK ALUMINUM OR STEEL.
- 15. SIGN FACE SHALL BE 1/4" THICK ALUMINUM OR STEEL.
- 16. SIGN FACE SHALL BE 1/4" THICK ALUMINUM OR STEEL.
- 17. SIGN FACE SHALL BE 1/4" THICK ALUMINUM OR STEEL.
- 18. SIGN FACE SHALL BE 1/4" THICK ALUMINUM OR STEEL.
- 19. SIGN FACE SHALL BE 1/4" THICK ALUMINUM OR STEEL.
- 20. SIGN FACE SHALL BE 1/4" THICK ALUMINUM OR STEEL.



rsp Architecture, Inc. 400-888-2000
202 E. Colfax
Sacramento, CA 95811
www.rsp.com

rsp Architecture, Inc. 400-888-2000
202 E. Colfax
Sacramento, CA 95811
www.rsp.com

SOLSTICE

Project No.	0988.001.06
Client	Arden Fair Mall
Location	1888 Arden Way Sacramento, CA 95815
Date	12.09.05
Scale	1/4" = 1'-0"
Drawn by	J.P. PLS
Checked by	PLS
Project Manager	PLS
Project Engineer	PLS
Project Architect	PLS
Project Designer	PLS
Project Signer	PLS
Project Seal	PLS
Project Stamp	PLS
Project Title	SPACE 2132

STOREFRONT ENLARGED PLAN
AND ELEVATION

A401

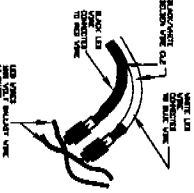
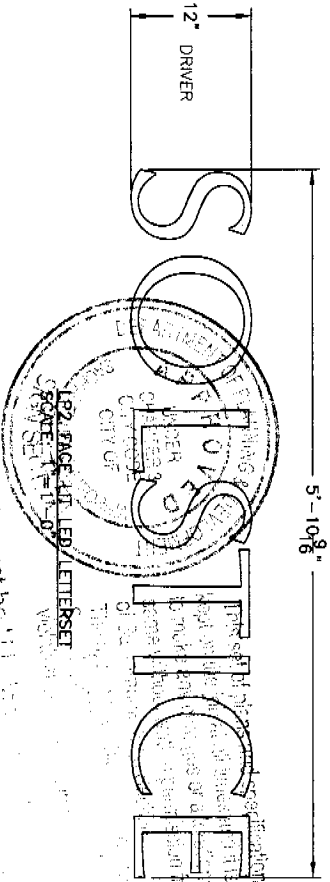

WIRE AND BUNDLE CONNECTION DETAIL
N.T.S.

- TRANSFORMER MUST BE INSTALLED IN TRANSFORMER BOX
- TRANSFORMER BOX AND TRANSFORMER MUST NOT BE EXPOSED TO OUTSIDE WEATHER CONDITIONS
- THIS SIGN TO BE AS UNDERWRITERS LABEL
- 120 VOLTS
- THE WIRE TIE MUST BE MADE IN SUCH A MANNER AS TO NOT BE SUBJECT TO DAMAGE FROM THE WIRE TIE ITSELF

SPECIFICATIONS:
PAINT:

(P1) RAL 9003 WHITE

WHILE THE APPROVAL OF ALL ELECTRICAL WORK IS SUBJECT TO FIELD INSPECTIONS.

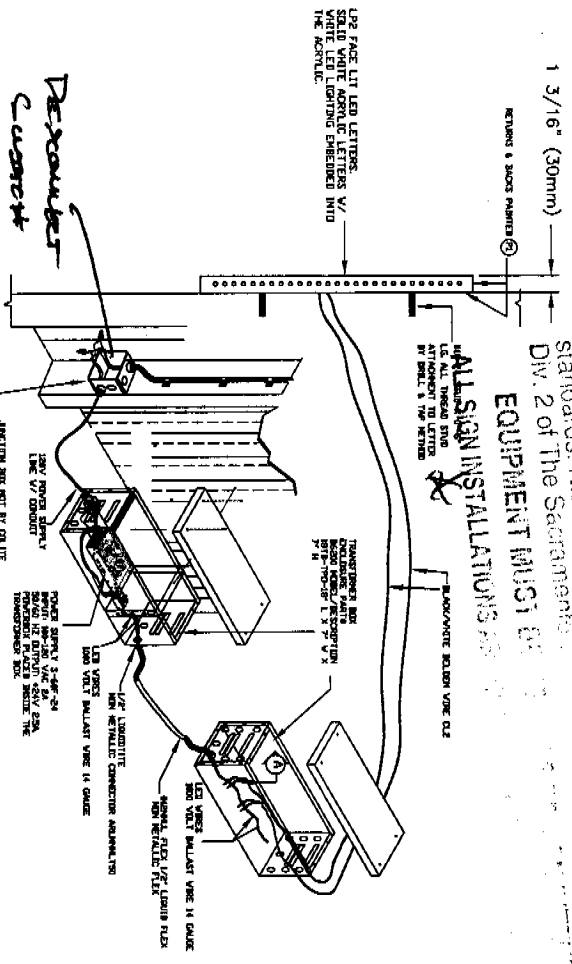

All electrical work must be in accordance with standards, N.E.C. Sec. 90.4 Div. 2 of The Sacramento EQUIPMENT MUST BE

"O" & "C" STROKES WIDTH INCREASED TO ACCOMMODATE LED'S.

PACKING LIST		
MATERIAL	QUANTITY	CHECK 1 CHECK 2 INSTALLER CHECK
LETTERSET	1	
WORKING PATTERN	1	
#10-24 ALL THREAD STUDS	40	
POWER SUPPLY 5-00P-24		
WIRE TIE 100-150 MAG 24		
WIRE BUNDLE WRAP 1/2\"/>		

FILE PATH: GRAPHICS SOLSTICE LPZ	12 INCH.FS
Rev. By	Date
DATE	
DESIGNER	PROJECT MANAGER
DRAWN BY	CHECKED BY
DATE	
1049	

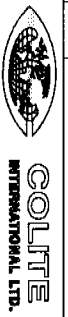

225 PARKWAY ST. • P.O. BOX 4001 • 2917 DALLAS, TX 75217 • TEL. (817) 508-1834

THIS IS AN ORIGINAL UNREPRODUCED DESIGN. OWNERSHIP OF THIS DESIGN IS RESERVED BY COLTTE INTERNATIONAL LTD. IT IS NOT TO BE REPRODUCED OR TRANSMITTED IN ANY FORM OR BY ANY MEANS, ELECTRONIC OR MECHANICAL, INCLUDING PHOTOCOPYING, RECORDING, OR BY ANY INFORMATION STORAGE AND RETRIEVAL SYSTEM. PERMISSION IS GRANTED TO MAKE A SINGLE COPY OF THIS DESIGN FOR PERSONAL USE ONLY. ALL OTHER RIGHTS ARE RESERVED.

PERMIT COPY
NOT FOR PRODUCTION



IS

EAST COMMERCE WAY

SAFEWAY
2851

US BANK
proposed sign

Scale 1/4" = 1'-0"

[Empty rectangular box]

TOWN CENTER DRIVE

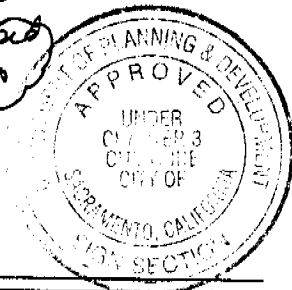

This set of plans and specifications must be kept on the job at all times and it is unlawful to make any changes or alterations from the same without written permission from the City of Sacramento Sign Section.
The approval of this plan and specification SHALL NOT be held to permit or approve the violation of any City Ordinance or State Law.

NATONAS DARK must be U.L. labeled or be of equivalent UL 90-6 and comply with chapter 14, Div. 2 of Sacramento City Code.

EQUIPMENT MUST BE USED AS DESIGN INTENDED

ALL SIGN INSTALLATIONS ARE SUBJECT TO FIELD INSPECTIONS

B/B
A

SAFEWAY
GAS STATION
PUMPS

WESTERN
SIERRA
BANK

[Empty rectangular box]

DEL PASO ROAD

Jackson
The Boy

chevron

CITY COPY

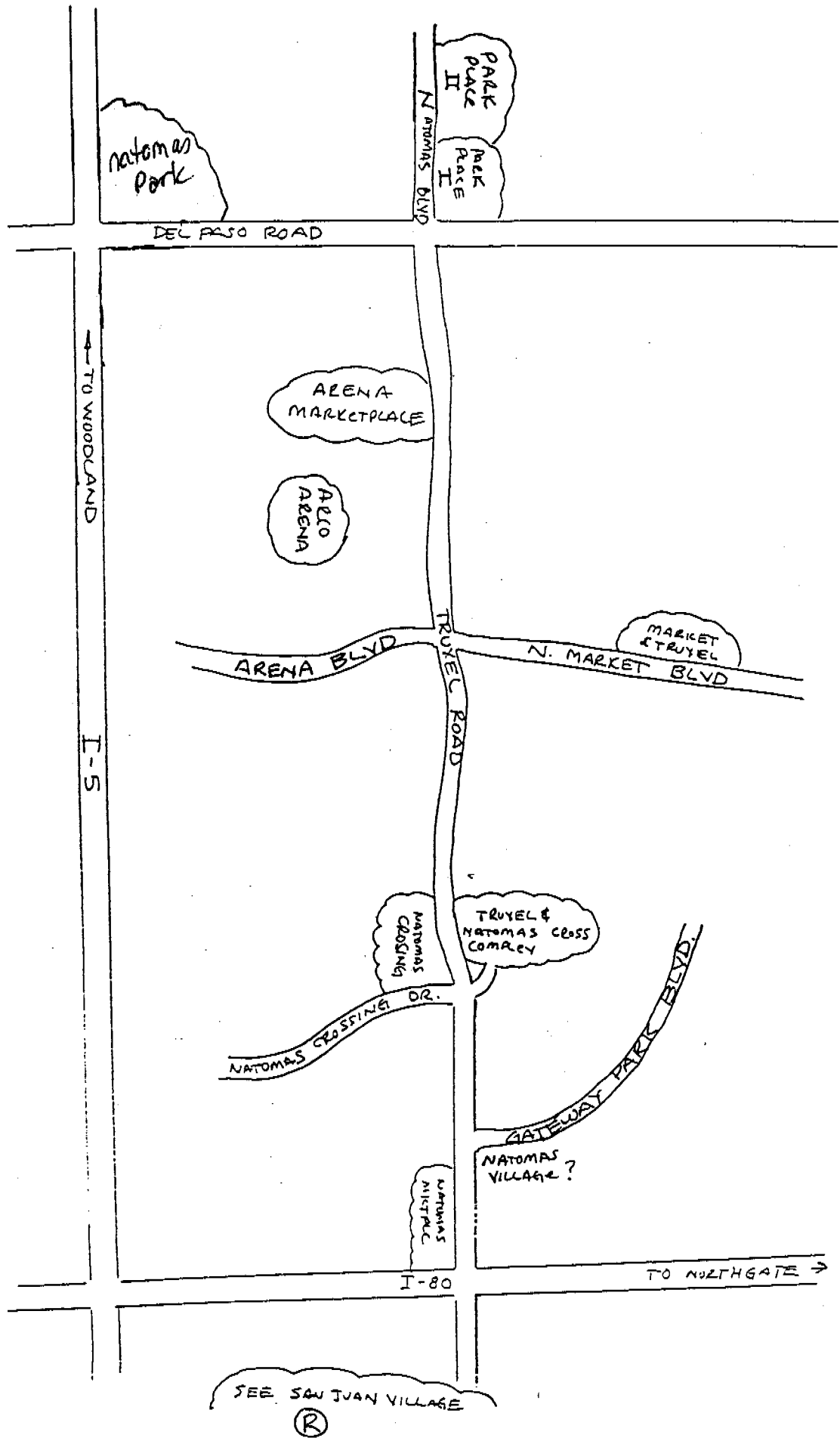

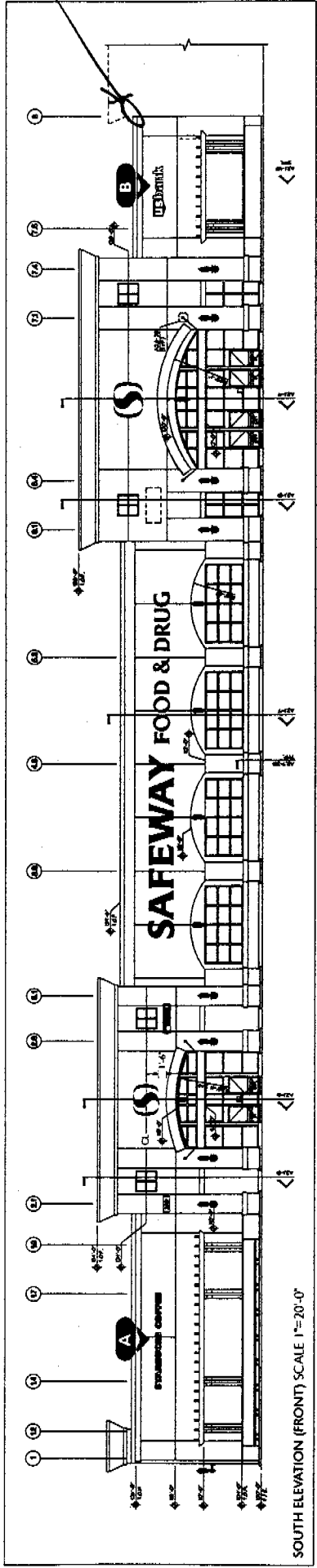

SOUTH ELEVATION (FRONT) SCALE 1" = 20'-0"

35'-0"
STARBUCKS COFFEE

A ILLUMINATED PAN CHANNEL LETTERS- 37.5 SQ. FT. SCALE 1/4" = 1'-0"

PREVIOUSLY REVIEWED AND APPROVED. CAPITOL NEON IS AUTHORIZED TO PERMIT, FABRICATE AND INSTALL "US BANK" SIGN ON THE SAFEWAY BUILDING.

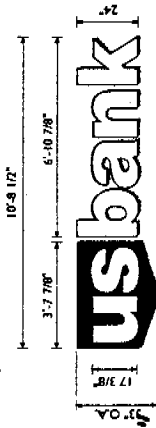

B ILLUMINATED PAN CHANNEL LETTERS- 20 SQ. FT. SCALE 1/4" = 1'-0"

*Amel 6.107
 10.6.15 PERMIT
 LEWIS CENTER*

SPECIFICATIONS

A 5" GREEN ALUMINUM RETURNS WITH 3/4" GREEN TRIMCAP
 WHITE 015-2 ACRYLIC FACES
 ILLUMINATE WITH 15MMH 6500 WHITE NEON.

B 5" ALUMINUM RETURNS WITH 1" TRIMCAP "US"
 PAINT RED TO MATCH PANTONE 193 RED "BANK"
 PAINT WHITE
 "US" WHITE ACRYLIC FACE WITH TRANSLUCENT VINYL FILM TO MATCH PANTONE 193 RED "BANK"
 ILLUMINATE WITH 15MMH WHITE NEON.

CALCULATIONS- SQUARE FOOTAGE

SAFEWAY: 188.5
 FOOD & DRUG 93.4
 LOGO (A) 33.3
 LOGO (B) 43.5
 SUB TOTAL 358.7

STARBUCKS 37.5
 US BANK (US 10 SQ FT) (BANK 10 SQ FT) = 20 SQ. FT.
 SUB TOTAL 57.5
 TOTAL SQUARE FOOTAGE 416.2

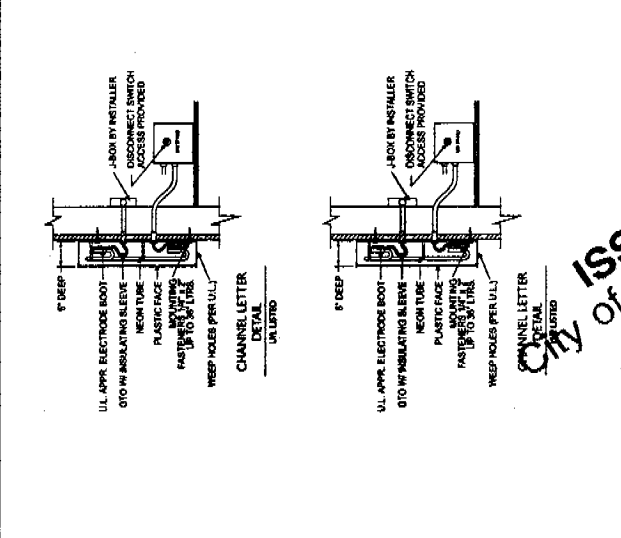

PACIFIC NEON
 2939 Academy Way
 Sacramento CA, 95815
 Ph: 916.972.0537
 Fax: 916.972.2114
 www.pacneon.com
 Copyright ©2004

Program: 04-9126-00
 Account: 2851
 Designer: JLSM
 Date: 10/27/2004

Revision
 A) 6.24.04
 B) 6.29.04
 C)
 H=1

ISSUED
 City of Sacramento
 OCT 27 2004
 MONTH PERMIT
 CENTER

SAFEWAY #2697 (US BANK-STARBUCKS)
 2851 Del Paso Road, Natomas Town Center, Sacramento

A. Print and electronic art remain the sole copyright property of Pacific Neon Company and are not to be distributed, copied, or transferred in any way without prior written release from Pacific Neon Company.