

**CITY OF SACRAMENTO**  
1231 I Street, Sacramento, CA 95814

**Permit No: 0503506**

**Insp Area: 4**  
**Thos Bros: 297G1**

**Site Address: 330 COMMERCE CR SAC**  
Parcel No: 275-0251-004

**Sub-Type: REP**  
**Housing (Y/N): N**

CONTRACTOR  
PARK MECHANICAL  
7975 RAMONA AV  
SACRAMENTO CA 95826

OWNER  
996 GALEN KLOKKEVOLD  
2708 47TH AV  
SACRAMENTO, CA 95822

ARCHITECT

**Nature of Work: 20 TON HVAC CHANGE OUT.**

**CONSTRUCTION LENDING AGENCY:** I hereby affirm under penalty of perjury that there is a construction lending agency for the performance of the work for which this permit is issued (Sec. 3097, Civ. C).

Lender's Name \_\_\_\_\_ Lender's Address \_\_\_\_\_

**LICENSED CONTRACTORS DECLARATION:** I hereby affirm under penalty of perjury that I am licensed under provisions of Chapter 9 (commencing with section 7000) of Division 3 of the Business and Professions Code and my license is in full force and effect.

License Class C-20 License Number 335561 Date 3/16/05 Contractor Signature [Signature]

**OWNER-BUILDER DECLARATION:** I hereby affirm under penalty of perjury that I am exempt from the contractors License Law for the following reason (Sec. 7031.5, Business and Professions Code; any city or county which requires a permit to construct, alter, improve, demolish, or repair any structure, prior to its issuance, also requires the applicant for such permit to file a signed statement that he or she is licensed pursuant to the provisions of the Contractors License Law (Chapter 9 (commencing with Section 7000) of Division 8 of the Business and Professions Code) or that he or she is exempt therefrom and the basis for the alleged exemption. Any violation of Section 7031.5 by any applicant for a permit subjects the applicant to a civil penalty of not more than five hundred dollars (\$500.00);

I, as a owner of the property, or my employees with wages as their sole compensation, will do the work, and the structure is not intended or offered for sale (Sec. 7044, Business and Professional Code: The Contractors License Law does not apply to an owner of property who builds or improves thereon, and who does such work himself or herself or through his/her own employees, provided that such improvements are not intended or offered for sale. If, however, the building or improvement is sold within one year of completion, the owner-builder will have the burden of proving that he/she did not build or improve for the purpose of sale.)

I, as owner of the property, am exclusively contracting with licensed contractors to construct the project (Sec. 7044, Business and Professions Code: The Contractors License Law does not apply to an owner of property who builds or improves thereon, and who contracts for such projects with a contractor(s) licensed pursuant to the Contractors License Law).

I am exempt under Sec. \_\_\_\_\_ B & PC for this reason: \_\_\_\_\_

Date \_\_\_\_\_ Owner Signature \_\_\_\_\_

**IN ISSUING THIS BUILDING PERMIT,** the applicant represents, and the city relies on the representation of the applicant, that the applicant verified all measurements and locations shown on the application or accompanying drawings and that the improvement to be constructed does not violate any law or private agreement relating to permissible or prohibited locations for such improvements. This building permit does not authorize any illegal location of any improvement or the violation of any private agreement relating to location of improvements.

I certify that I have read this application and state that all information is correct. I agree to comply with all city and county ordinances and state laws relating to building construction and hereby authorize representative(s) of this city to enter upon the abovementioned property for inspection purposes.

Date 3/16/05 Applicant/Agent Signature [Signature]

**WORKER'S COMPENSATION DECLARATION:** I hereby affirm under penalty of perjury one of the following declarations:

I have and will maintain a certificate of consent to self-insure for workers' compensation as provided for by Section 3700 of the Labor Code, for the performance of work for which the permit is issued.

I have and will maintain workers' compensation insurance, as required by Section 3700 of the Labor Code, for the performance of the work for which this permit is issued. My workers' compensation insurance carrier and policy number are:

Carrier STATE FUND Policy Number 1759244-2004 Exp Date 10/01/2005

[Initials] (This section need not be completed if the permit is for \$100 or less) I certify that in the performance of the work for which this permit is issued, I shall not employ any person in any manner so as to become subject to the workers' compensation laws of California and agree that if I should become subject to the workers' compensation provisions of Section 3700 of the Labor Code, I shall forthwith comply with those provisions.

Date 3/16/05 Applicant Signature [Signature]

**WARNING: FAILURE TO SECURE WORKER'S COMPENSATION COVERAGE IS UNLAWFUL AND SHALL SUBJECT AN EMPLOYER TO CRIMINAL PENALTIES AND CIVIL FINES UP TO ONE HUNDRED THOUSAND DOLLARS (\$100,000) IN ADDITION TO THE COST OF COMPENSATION, DAMAGES AS PROVIDED FOR IN SECTION 3706 OF THE LABOR CODE, INTEREST AND ATTORNEY'S FEE.**

**THIS PERMIT SHALL EXPIRE BY LIMITATION IF WORK IS NOT COMMENCED WITHIN 180 DAYS.**

# APPLICATION FOR COMMERCIAL BUILDING PERMIT

**CITY OF SACRAMENTO  
DEVELOPMENT SERVICES DIVISION  
PERMIT SERVICES SECTION**  
1231 I Street, Rm. 200  
Sacramento, CA 95814 (916) 264-7619 FAX: 264-7046

ACTIVITY # <span style="font-size: 1.5em; font-family: cursive;">0503506</span>	Insp. Area <span style="font-size: 1.5em; font-family: cursive;">4C</span>
--	---

Applicant **MUST** complete ALL Unshaded Areas

ADDRESS: 330 COMMERCE CIRCLE Suite: \_\_\_\_\_  
 PARCEL #: 275-0251-004-0000

<p style="text-align: center;"><b>CONTACT</b></p> <p>Name: <u>COREY HATANAKA</u>                  Street Address: <u>7975 RAMONA AVE</u>                  City/State/Zip: <u>SACRAMENTO, CA 95826</u>                  Phone: <u>(916) 452-5557 (CELL) (916) 997-7216</u>                  E-Mail: <u>COREY@PARKMECHANICAL.COM</u></p>	<p style="text-align: center;"><b>LICENSED CONTRACTOR</b> Lic No. # <u>335561</u></p> <p>Name: <u>PARK MECHANICAL, INC</u>                  Street Address: <u>7975 RAMONA AVE</u>                  City/State/Zip: <u>SACRAMENTO, CA 95826</u>                  Phone: <u>(916) 452-5557</u>                  E-Mail: <u>INFO@PARKMECHANICAL.COM</u></p>
<p style="text-align: center;"><b>ARCHITECT/ENGINEER</b></p> <p>Name: <u>SIGMA ENGINEERING</u>                  Street Address: <u>3517 MARCONI AVE STE. 204</u>                  City/State/Zip: <u>SACRAMENTO, CA 95821</u>                  Phone: <u>(916) 483-7343</u>                  E-Mail: <u>SIGMAENG@EARTHLINK-NET</u></p>	<p style="text-align: center;"><b>OWNER</b></p> <p>Name: <u>GALEN KLOCKEVOLD TRUST</u>                  Street Address: <u>330 COMMERCE CIRCLE</u>                  City/State/Zip: <u>SACRAMENTO, CA 95815</u>                  Phone: <u>(916) 422-3110</u>                  E-Mail: _____</p>

⇒ Will permittee have any employees on the jobsite?  No  Yes ⇒ Insurance Co.: STATE FUND  
 ⇒ WORKER'S COMPANSATION POLICY # 1759244-2004 EXPIRATION DATE: 10/1/05

NATURE OF WORK IN DETAIL: 20 TON AIR CONDITIONING CHANGE OUT  
 OCCUPANT/TENANT: \_\_\_\_\_ VALUATION: \$59,027<sup>00</sup>

FLOOD STATUS:			S.C.A.T.							
JOB DISCRPTION	BLDG	SHELL	APT	TI( )	REM( )	SW	FIRE	ADD	OTH	
INSPECTION DISCIPLINES			BLDG	MECH	PLUMB	ELEC		SITE	FIRE	
# Stories	1 <sup>st</sup> Flr Area	Total Area	Use Zone	Equip Group	Count type	Fire Req. Y / N		Fed Code	Vio. File	
						SPR	ALARM		[H] [Quad]	
B	L	P	M	E	F	S		D	PW UTIL	

COMMENTS: \_\_\_\_\_  
 \_\_\_\_\_  
 \_\_\_\_\_

REGIONAL SANITATION FEES?  Yes  No HEALTH DEPARTMENT:  Yes  No  
 WATER FLOW TEST FOR NEW BUILDINGS OR ADDITIONS?  Provided  Faxed

**HS29**

6 to 20 Ton (21.1 to 70.3 kW)

Cooling Capacity - 61,000 to 240,000 Btuh (17.8 to 70.3 kW)

Bulletin No. 21O307  
December 2000



CERTIFICATION APPLIES ONLY  
WHEN THE COMPLETE  
SYSTEM IS LISTED  
WITH ARI



CERTIFICATION APPLIES ONLY  
WHEN THE COMPLETE  
SYSTEM IS LISTED  
WITH ARI

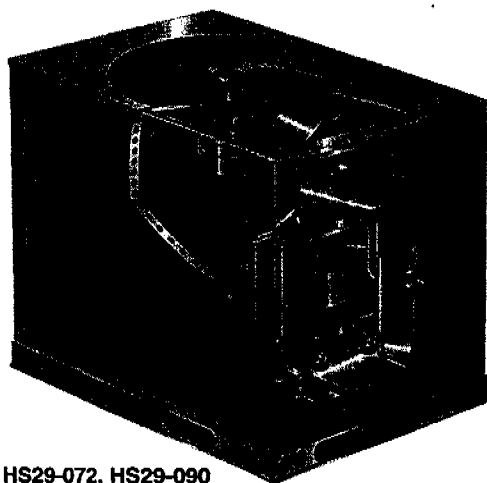
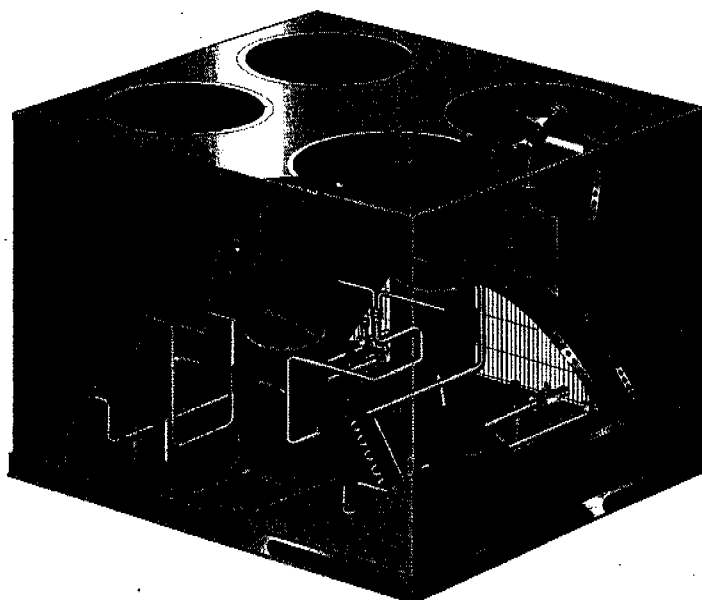

HS29-072, HS29-090

HS29-180, HS29-240

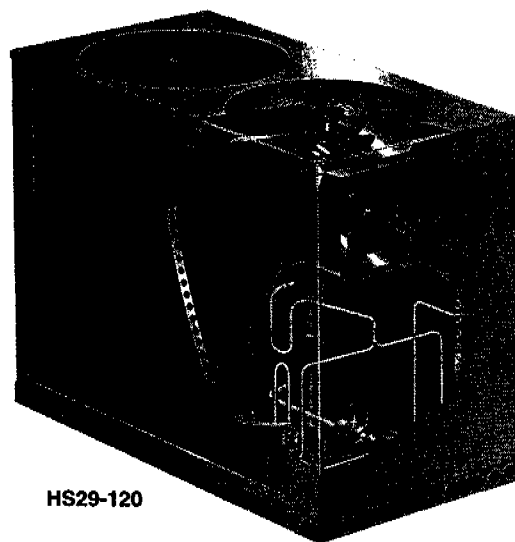

HS29-120

**Typical Applications**

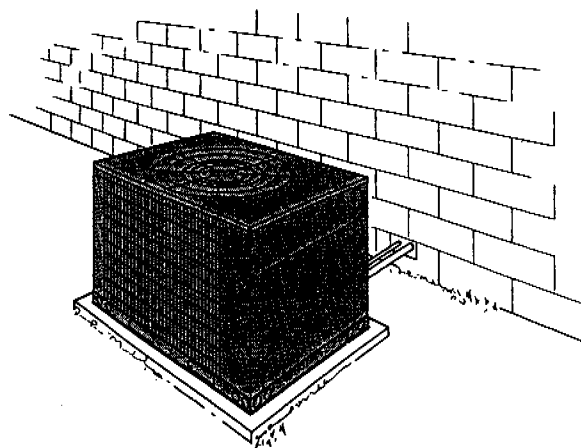

Unit on a slab at grade level

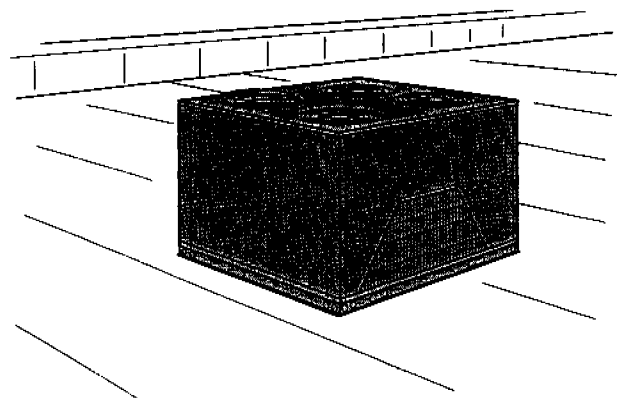

Rooftop Installation

NOTE - Due to Lennox' ongoing commitment to quality, Specifications, Ratings and Dimensions subject to change without notice and without incurring liability. Improper installation, adjustment, alteration, service or maintenance can cause property damage or personal injury. Installation and service must be performed by a qualified installer and servicing agency.

# DIMENSIONS - HS29-180 & HS29-240

## CORNER WEIGHT

Model No.	AA		BB		CC		DD	
	lbs.	kg	lbs.	kg	lbs.	kg	lbs.	kg
HS29-180	232	105	227	103	227	103	232	105
HS29-240	287	130	287	130	268	122	268	122

## CENTER OF GRAVITY

Model No.	EE		FF	
	inch	mm	inch	mm
HS29-180	29-1/4	743	33-1/4	845
HS29-240	28-1/2	724	33-1/4	845

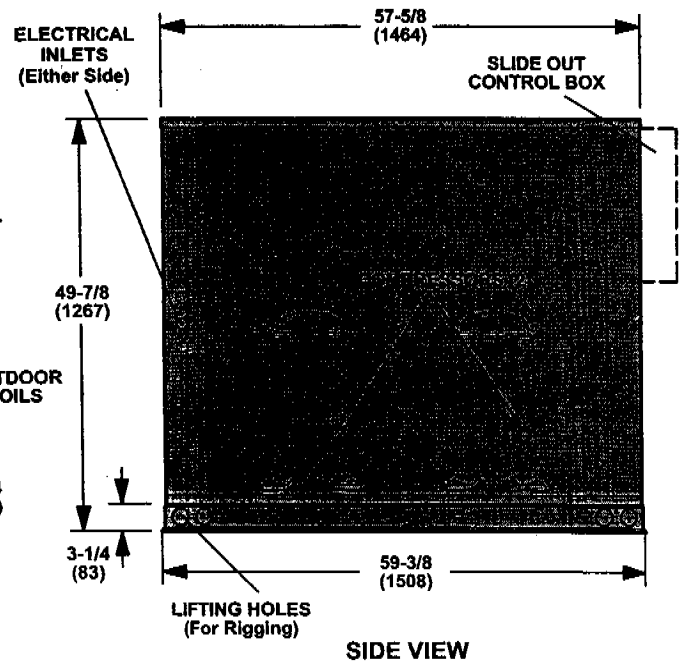
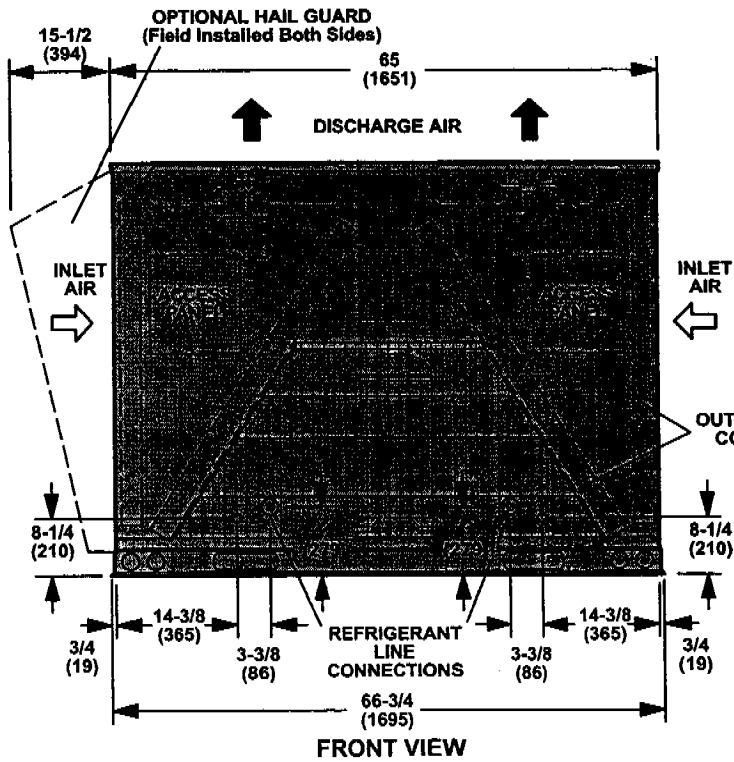
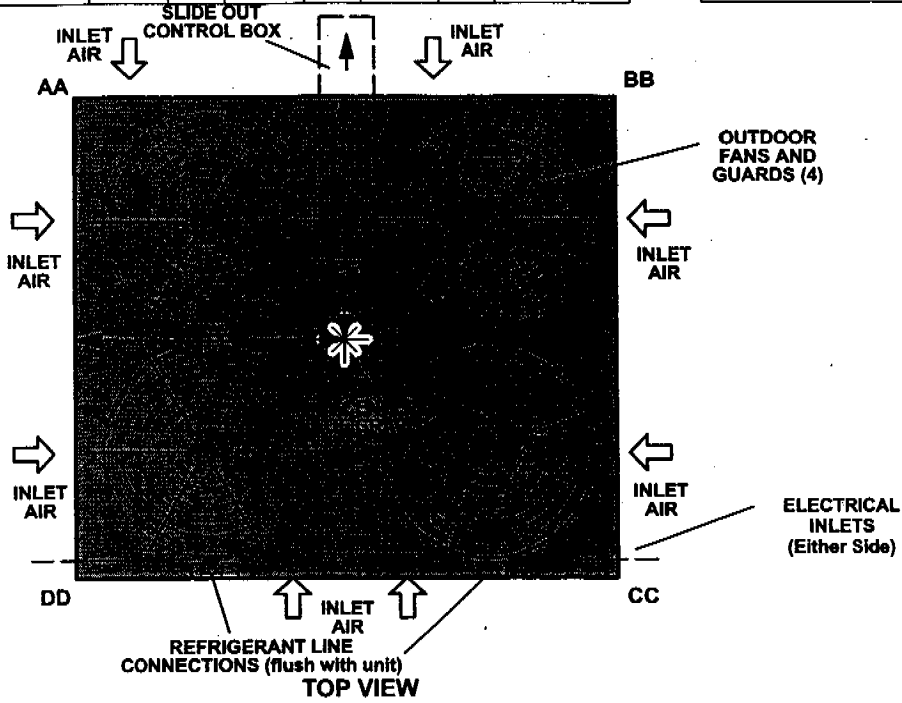

# COOLING RATINGS

NOTE - For Temperatures and Capacities not shown in tables, see bulletin - Cooling Unit Rating Table Correction Factor Data in Miscellaneous Engineering Data section. All values are gross capacities and do not include evaporator coil blower motor heat deduction.

## HS29-240 — CB17/CB17-275 COOLING CAPACITY - ONE COMPRESSOR OPERATING

Entering Wet Bulb Temperature	Total Air Volume		Outdoor Air Temperature Entering Outdoor Coil																							
			65°F (18°C)						75°F (24°C)						85°F (29°C)						95°F (35°C)					
			Total Cooling Capacity		Comp Motor kW Input	Sensible To Total Ratio (S/T)			Total Cooling Capacity		Comp Motor kW Input	Sensible To Total Ratio (S/T)			Total Cooling Capacity		Comp Motor kW Input	Sensible To Total Ratio (S/T)			Total Cooling Capacity		Comp Motor kW Input	Sensible To Total Ratio (S/T)		
						Dry Bulb						Dry Bulb						Dry Bulb						Dry Bulb		
cfm	L/s	kBtuh	kW	75°F 24°C	80°F 27°C	85°F 29°C	kBtuh	kW	Input	75°F 24°C	80°F 27°C	85°F 29°C	kBtuh	kW	Input	75°F 24°C	80°F 27°C	85°F 29°C	kBtuh	kW	Input	75°F 24°C	80°F 27°C	85°F 29°C		
63°F (17°C)	6400	3020	124.3	36.4	7.46	.67	.81	.93	120.8	35.4	8.21	.68	.82	.94	117.1	34.3	9.07	.69	.83	.96	113.1	33.1	10.03	.70	.84	.97
	8000	3775	129.3	37.9	7.58	.72	.88	.99	125.6	36.8	8.33	.73	.89	1.00	121.7	35.7	9.18	.74	.90	1.00	117.6	34.5	10.15	.75	.92	1.00
	9600	4530	133.3	39.1	7.66	.77	.94	1.00	129.6	38.0	8.42	.78	.95	1.00	125.6	36.8	9.27	.80	.97	1.00	121.4	35.6	10.24	.81	.98	1.00
67°F (19°C)	6400	3020	132.3	38.8	7.63	.53	.65	.77	128.5	37.7	8.38	.54	.66	.78	124.5	36.5	9.23	.54	.66	.79	120.2	35.2	10.21	.55	.67	.81
	8000	3775	136.8	40.1	7.74	.56	.70	.84	132.8	38.9	8.48	.56	.70	.86	128.5	37.7	9.33	.57	.72	.87	124.0	36.3	10.29	.58	.73	.89
	9600	4530	140.0	41.0	7.81	.59	.75	.91	135.9	39.8	8.55	.59	.76	.92	131.5	38.5	9.40	.60	.77	.94	126.8	37.2	10.37	.61	.79	.96
71°F (22°C)	6400	3020	141.1	41.4	7.83	.41	.51	.62	137.1	40.2	8.58	.41	.52	.63	132.7	38.9	9.43	.41	.52	.64	128.1	37.5	10.41	.41	.53	.65
	8000	3775	145.6	42.7	7.93	.41	.54	.67	141.3	41.4	8.68	.41	.55	.68	136.7	40.1	9.53	.42	.56	.69	131.8	38.6	10.50	.42	.56	.71
	9600	4530	148.6	43.6	8.01	.42	.57	.72	144.2	42.3	8.75	.43	.58	.74	139.4	40.9	9.60	.43	.59	.75	134.3	39.4	10.57	.43	.60	.77

## HS29-240 — CB17/CB17-275 COOLING CAPACITY - BOTH COMPRESSORS OPERATING

Entering Wet Bulb Temperature	Total Air Volume		Outdoor Air Temperature Entering Outdoor Coil																							
			85°F (29°C)						95°F (35°C)						105°F (41°C)						115°F (46°C)					
			Total Cooling Capacity		Comp Motor kW Input	Sensible To Total Ratio (S/T)			Total Cooling Capacity		Comp Motor kW Input	Sensible To Total Ratio (S/T)			Total Cooling Capacity		Comp Motor kW Input	Sensible To Total Ratio (S/T)			Total Cooling Capacity		Comp Motor kW Input	Sensible To Total Ratio (S/T)		
						Dry Bulb						Dry Bulb						Dry Bulb						Dry Bulb		
cfm	L/s	kBtuh	kW	75°F 24°C	80°F 27°C	85°F 29°C	kBtuh	kW	Input	75°F 24°C	80°F 27°C	85°F 29°C	kBtuh	kW	Input	75°F 24°C	80°F 27°C	85°F 29°C	kBtuh	kW	Input	75°F 24°C	80°F 27°C	85°F 29°C		
63°F (17°C)	6400	3020	233.4	68.4	18.40	.72	.85	.96	225.5	66.1	20.37	.73	.86	.97	217.0	63.6	22.62	.74	.88	.98	207.9	60.9	25.23	.75	.90	.99
	8000	3775	242.6	71.1	18.62	.77	.92	1.00	234.5	68.7	20.60	.78	.93	1.00	225.7	66.1	22.86	.80	.96	1.00	216.4	63.4	25.45	.81	.96	1.00
	9600	4530	250.4	73.4	18.80	.82	.97	1.00	242.1	71.0	20.79	.83	.98	1.00	233.5	68.4	23.06	.85	.99	1.00	224.1	65.7	25.67	.87	.99	1.00
67°F (19°C)	6400	3020	247.9	72.7	18.72	.56	.69	.82	239.4	70.2	20.71	.57	.70	.83	230.2	67.5	22.95	.58	.72	.85	220.3	64.6	25.55	.58	.73	.87
	8000	3775	255.9	75.0	18.92	.59	.75	.89	247.0	72.4	20.88	.60	.76	.90	237.3	69.5	23.16	.61	.77	.92	226.8	66.5	25.78	.62	.79	.94
	9600	4530	261.8	76.7	19.06	.63	.80	.94	252.5	74.0	21.04	.64	.81	.96	242.5	71.1	23.33	.65	.83	.97	231.9	68.0	25.93	.66	.85	.98
71°F (22°C)	6400	3020	264.3	77.5	19.11	.43	.55	.67	255.2	74.8	21.11	.43	.55	.68	245.4	71.9	23.39	.43	.56	.69	234.7	68.8	25.98	.43	.57	.70
	8000	3775	272.1	79.7	19.31	.44	.58	.72	262.5	76.9	21.29	.44	.59	.74	252.1	73.9	23.57	.44	.60	.75	240.9	70.6	26.17	.45	.61	.77
	9600	4530	277.4	81.3	19.45	.45	.62	.78	267.4	78.4	21.43	.45	.63	.79	256.8	75.3	23.69	.46	.64	.81	245.2	71.9	26.32	.46	.65	.83

## HS29-240 — (TWO) CB17/CB17-135 COOLING CAPACITY - ONE COMPRESSOR OPERATING

Entering Wet Bulb Temperature	Total Air Volume		Outdoor Air Temperature Entering Outdoor Coil																							
			65°F (18°C)						75°F (24°C)						85°F (29°C)						95°F (35°C)					
			Total Cooling Capacity		Comp Motor kW Input	Sensible To Total Ratio (S/T)			Total Cooling Capacity		Comp Motor kW Input	Sensible To Total Ratio (S/T)			Total Cooling Capacity		Comp Motor kW Input	Sensible To Total Ratio (S/T)			Total Cooling Capacity		Comp Motor kW Input	Sensible To Total Ratio (S/T)		
						Dry Bulb						Dry Bulb						Dry Bulb						Dry Bulb		
cfm	L/s	kBtuh	kW	75°F 24°C	80°F 27°C	85°F 29°C	kBtuh	kW	Input	75°F 24°C	80°F 27°C	85°F 29°C	kBtuh	kW	Input	75°F 24°C	80°F 27°C	85°F 29°C	kBtuh	kW	Input	75°F 24°C	80°F 27°C	85°F 29°C		
63°F (17°C)	3200	1510	120.2	35.2	7.40	.71	.84	.96	116.8	34.2	8.15	.72	.85	.97	113.2	33.2	8.98	.73	.86	.98	109.3	32.0	9.94	.74	.88	.99
	4000	1890	125.0	36.8	7.52	.76	.90	1.00	121.4	35.6	8.25	.77	.92	1.00	117.5	34.4	9.09	.78	.93	1.00	113.5	33.3	10.05	.79	.95	1.00
	4800	2265	128.7	37.7	7.60	.81	.96	1.00	124.9	36.6	8.35	.82	.97	1.00	121.1	35.5	9.18	.83	.99	1.00	117.0	34.3	10.13	.85	1.00	1.00
67°F (19°C)	3200	1510	127.9	37.5	7.58	.57	.69	.81	124.2	36.4	8.31	.57	.70	.82	120.2	35.2	9.15	.57	.70	.83	116.0	34.0	10.10	.58	.71	.84
	4000	1890	132.2	38.7	7.68	.59	.74	.87	128.2	37.6	8.41	.60	.75	.89	124.1	36.4	9.24	.60	.76	.90	119.6	35.1	10.20	.61	.77	.92
	4800	2265	135.2	39.6	7.75	.62	.78	.93	131.1	38.4	8.48	.63	.80	.95	126.8	37.2	9.32	.64	.81	.96	122.2	35.8	10.28	.64	.83	.98
71°F (22°C)	3200	1510	136.3	39.9	7.77	.43	.55	.66	132.3	38.8	8.51	.43	.55	.67	128.1	37.5	9.35	.43	.56	.68	123.6	36.2	10.31	.43	.56	.69
	4000	1890	140.5	41.2	7.88	.44	.58	.71	136.3	39.9	8.61	.44	.58	.72	131.8	38.6	9.45	.44	.59	.73	127.1	37.2	10.40	.45	.60	.75
	4800	2265	143.4	42.0	7.95	.45	.61	.76	139.0	40.7	8.68	.45	.61	.77	134.4	39.4	9.51	.46	.62	.79	129.4	37.9	10.47	.46	.63	.80

## HS29-240 — (TWO) CB17/CB17-135 COOLING CAPACITY - BOTH COMPRESSORS OPERATING

Entering Wet Bulb Temperature	Total Air Volume		Outdoor Air Temperature Entering Outdoor Coil																							
			85°F (29°C)						95°F (35°C)						105°F (41°C)						115°F (46°C)					
			Total Cooling Capacity		Comp Motor kW Input	Sensible To Total Ratio (S/T)			Total Cooling Capacity		Comp Motor kW Input	Sensible To Total Ratio (S/T)			Total Cooling Capacity		Comp Motor kW Input	Sensible To Total Ratio (S/T)			Total Cooling Capacity		Comp Motor kW Input	Sensible To Total Ratio (S/T)		
						Dry Bulb						Dry Bulb						Dry Bulb						Dry Bulb		
cfm	L/s	kBtuh	kW	75°F 24°C	80°F 27°C	85°F 29°C	kBtuh	kW	Input	75°F 24°C	80°F 27°C	85°F 29°C	kBtuh	kW	Input	75°F 24°C	80°F 27°C	85°F 29°C	kBtuh	kW	Input	75°F 24°C	80°F 27°C	85°F 29°C		
63°F (17°C)	6400	3020	226.4	66.4	17.94	.73	.86	.98	218.6	64.1	19.86	.74	.88	.99	210.2	61.6	22.04	.75	.89	1.00	201.0	58.9	24.56	.76	.91	1.00
	8000	3775	235.0	68.9	18.16	.78	.93	1.00	226.8	66.5	20.08	.79	.95	1.00	218.2	63.9	22.26	.81	.96	1.00	209.0	61.3	24.76	.82	.98	1.00
	9600	4530	242.2	71.0	18.34	.83	.99	1.00	234.0	68.8	20.24	.85	1.00	1.00	225.2	66.0	22.44	.86	1.00	1.00	216.4	63.4	24.98	.88	1.00	1.00
67°F (19°C)	6400	3020	240.4	70.5	18.30	.57	.70	.83	232.0	68.0	20.18	.58	.71	.84	223.0	65.4	22.38	.59	.72	.86	213.0	62.4	24.92	.59	.74	.88
	8000	3775	248.0	72.7	18.46	.60	.76	.90	239.2	70.1	20.38	.61	.77	.92	229.6	67.3	22.60	.62	.79	.93	219.2	64.2	25.10	.63	.80	.96
	9600	4530	253.6	74.3	18.62	.64	.81	.96	244.4	71.6	20.54	.64	.82	.98	234.6	68.8	22.72	.66	.84	.99	224.0	65.6	25.24	.67	.86	1.00
71°F (22°C)	6400	3020	256.0	75.0	18.68	.43	.56	.68	247.0	72.4	20.60	.43	.56	.69	237.4	69.6	22.78	.44	.57	.70	227.0	66.5	25.32	.44	.58	.71
	8000	3775	263.6	77.3	18.88	.44	.59	.73	254.0	74.4	20.78	.45	.60	.75	243.8	71.5	23.00	.45	.61	.76	232.8	68.2	25.56	.45	.62	.78
	9600	4530	268.6	78.7	19.02	.46	.62	.79	258.8	75.8	20.92	.46	.63	.80	248.2	72.7	23.14	.46	.65	.82	237.0	69.5	25.64			

**CB17 SERIES — UP-FLOW**  
**CBH17 SERIES — HORIZONTAL**  
**BLOWER-COIL-FILTER UNITS**

**\*71,000 to 246,000 Btuh (20.8 to 72.1 kW) Cooling Capacity**  
**\*85,000 to 232,000 Btuh (24.9 to 68.0 kW) Heat Pump Heating Capacity**  
**35,500 to 204,800 Btuh (10.4 to 60.0 kW) Optional Electric Heat**  
**100,000 to 425,000 Btuh (29.3 to 124.5 kW) Optional Hot Water Heat**  
\*ARI Certified Ratings

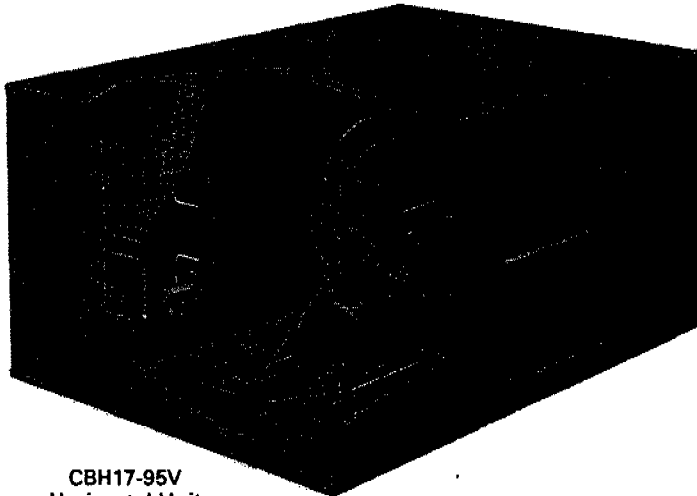

CBH17-95V  
Horizontal Unit

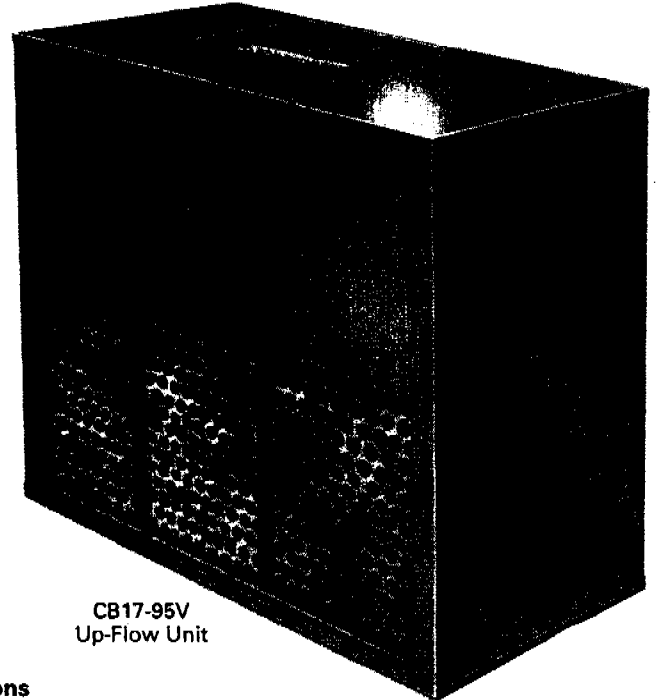

CB17-95V  
Up-Flow Unit

**Typical Applications**

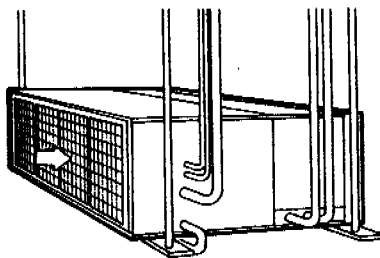

Horizontal Store Installation With  
Optional Hot Water Heat Section and  
Supply Air Plenum and Grille

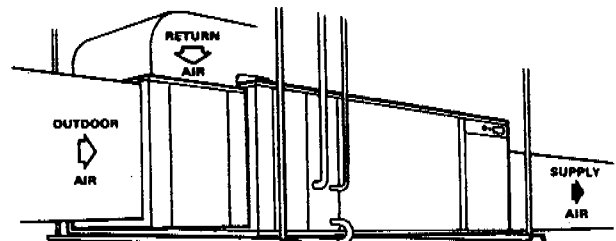

Suspended Horizontal Installation  
With Optional Electric Heat and  
Economizer Dampers

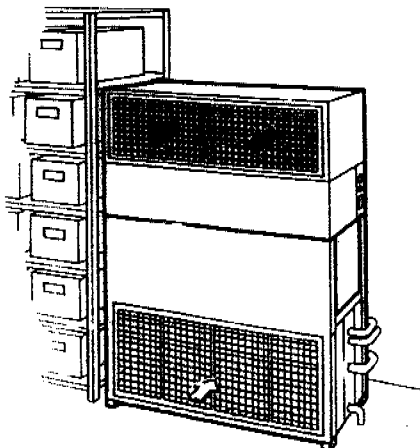

Vertical Store Cooler Installation With  
Optional Electric Heat Section and  
Supply Air Plenum and Grille

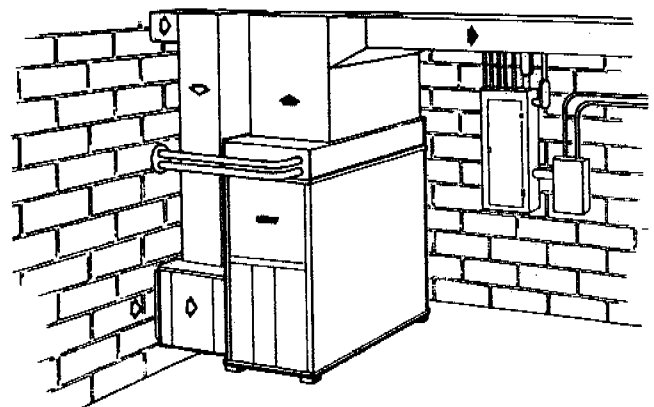

Up-Flow Installation With  
Optional Hot Water Heat Section and  
Economizer Dampers

♣ The maple leaf symbol in this bulletin denotes Canadian only usage where applicable

NOTE — Due to Lennox' ongoing commitment to quality, Specifications, Ratings and Dimensions subject to change without notice and without incurring liability.

# SPECIFICATIONS

Model Number		CB17-95V CBH17-95V	CB17-135V CBH17-135V	CB17-185V CBH17-185V	CB17-275V CBH17-275V	
Nominal Cooling Capacity — Tons (kW)		7-1/2 (26)	10 (35)	15 (53)	20 (70)	
Blower wheel nominal diameter x width — in. (mm)		(1) 15 x 15 (381 x 381)	(2) 15 x 9 (381 x 229)	(2) 15 x 11 (381 x 279)	(2) 15 x 15 (381 x 381)	
Blower motor output and blower drives		See Drive Kit Table (shipped separately)				
*Number and size of air filters	in.	(2) 16 x 25 x 1 (1) 20 x 25 x 1	(4) 16 x 25 x 1	(6) 16 x 20 x 1 (2) 16 x 25 x 1	(6) 20 x 20 x 1 (2) 20 x 25 x 1	
	mm	(2) 406 x 635 x 25 (1) 508 x 635 x 25	(4) 406 x 635 x 25	(6) 406 x 508 x 25 (2) 406 x 635 x 25	(6) 508 x 508 x 25 (2) 508 x 635 x 25	
Condensate drain connection — female pipe thread	in.	(2) 1-1/4	(2) 1-1/4	(2) 1-1/4	(2) 1-1/4	
	mm	(2) 31.8	(2) 31.8	(2) 31.8	(2) 31.8	
Refrigerant		HCFC-22				
Evaporator Coil	Net face area — ft. <sup>2</sup> (m <sup>2</sup> )		7.98 (0.74)	10.07 (0.94)	17.38 (1.61)	23.16 (2.15)
	Coil split — 1st stage/2nd stage (%)		60/40	61.9/38.1	53.8/46.2	52.9/47.1
	Number of rows		4	4	4	4
	Tube outside diameter — in. (mm)		3/8 (9.5)	3/8 (9.5)	1/2 (12.7)	1/2 (12.7)
	Fins per inch (fins per m)		14 (551)	14 (551)	13 (512)	13 (512)
	Suction line connection — outside diameter (sweat)	in.	1-3/8	1-3/8	(2) 1-1/8	(2) 1-3/8
		mm	34.9	34.9	(2) 28.5	(2) 34.9
	Liquid line connection — outside diameter (sweat)	in.	(2) 3/8	(2) 3/8	(2) 1/2	(4) 3/8
mm		(2) 9.5	(2) 9.5	(2) 12.7	(4) 9.5	
**Shipping weight — lbs. (kg) (†2 packages)	Up-flow	350 (159)	418 (190)	720 (327)	815 (370)	
	Horizontal	312 (142)	379 (172)	760 (345)	860 (390)	
◀ Optional Accessories (Must Be Ordered Extra) ▶						
Electric Heat Model Number		EH17-95	EH17-135	EH17-185/275		
Hot Water Coil	Model Number		HW17-95 (41F20)	HW17-135 (41F21)	HW17-185/275 (27G75)	
	Shipping weight — lbs. (kg)		95 (43)	104 (47)	160 (73)	
	††Heating capacity — Btuh (kW)		185,000 (54.2)	257,000 (75.3)	405,000 (118.7)	462,000 (135.4)
	Net face area — ft. <sup>2</sup> (m <sup>2</sup> )		6.4 (0.59)	8.5 (0.79)	15.6 (1.45)	
	Tube outside diameter — in. (mm) number of rows		1/2 (12.7) 2	1/2 (12.7) 2	1/2 (12.7) 2	
	Fins per inch (fins per m)		12 (472)	12 (472)	12 (472)	
	Water line connections Outside diameter — in. (mm)	Inlet	1-3/8 (35) sweat	1-3/8 (35) sweat	1-5/8 (41) sweat	
Outlet		1-3/8 (35) sweat	1-3/8 (35) sweat	1-5/8 (41) sweat		
Supply Air Plenum and Grille (shipping weight)		Up-flow	SPG17-95 (68F08) 124 lbs. (56 kg)	SPG17-135 (68F09) 148 lbs. (67 kg)	SPG17-185/275 (25G89) 242 lbs. (110 kg)	
		Horizontal	SPGH17-95 (68F10) 41 lbs. (19 kg)	SPGH17-135 (68F11) 50 lbs. (23 kg)	SPGH17-185/275 (25G88) 86 lbs. (39 kg)	
Return Air Grille (shipping weight)		RG17-95 (68F14) 29 lbs. (13 kg)	RG17-135 (68F15) 37 lbs. (17 kg)	RG17-185 (25G97) 65 lbs. (29 kg)	RG17-275 (25G98) 82 lbs. (37 kg)	
Empty Spacer Cabinet (shipping weight)		CB17-95-00 (50F06) 55 lbs. (25 kg)	CB17-135-00 (50F07) 60 lbs. (27 kg)	CB17-185/275-00 (27G76) 82 lbs. (37 kg)		
Economizer Dampers (shipping weight)		EMD17M-95 (74G20) 145 lbs. (66 kg)	EMD17M-135 (74G21) 185 lbs. (84 kg)	EMD17M-185 (43G63) 395 lbs. (179 kg)	EMD17M-275 (43G64) 542 lbs. (264 kg)	
Differential Enthalpy Control		54G44				
CBH17 Horizontal Suspension Kit (shipping weight)		LB-50866CA (44F93) 21 lbs. (10 kg)	LB-50866CB (44F94) 25 lbs. (11 kg)	Not Available		
Heat Pump Check Valve Kit		LB-51486CA (53F21)	LB-51486CA (53F21)	LB-55674CA (29G19)	LB-51486CB (29G20)	

\*Standard filters are 1 inch (25 mm) thick. 2 inch (51 mm) filters may also be used.

\*\*Weight does not include motor and drives.

†Packages consist of: blower coil unit and drive kit with motor and drives.

††Rated at 180°F (82°C) supply water temperature, 70°F (21°C) entering air temperature, 20°F (11°C) water temperature drop and 450 cfm air volume per ton (60 L/s air volume per kW) of cooling capacity. See Hot Water Capacity Curves for heating capacities at different conditions.

# BLOWER DATA

## CB17-275V AND CBH17-275V BLOWER PERFORMANCE

Air Volume cfm (L/s)	STATIC PRESSURE EXTERNAL TO UNIT — Inches Water Gauge (Pa)										
	0.1 (25)	0.2 (50)	0.3 (75)	0.4 (100)	0.5 (125)	0.6 (150)	0.7 (175)	0.8 (200)	0.9 (225)	1.0 (250)	1.25 (310)
	RPM hp (W)	RPM hp (W)	RPM hp (W)	RPM hp (W)	RPM hp (W)	RPM hp (W)	RPM hp (W)	RPM hp (W)	RPM hp (W)	RPM hp (W)	RPM hp (W)
6500 (3065)	515 1.35 (1007)	535 1.45 (1082)	570 1.70 (1268)	585 1.80 (1343)	615 1.90 (1417)	635 2.00 (1492)	670 2.25 (1679)	690 2.30 (1716)	720 2.45 (1828)	740 2.50 (1865)	805 2.95 (2201)
7000 (3305)	525 1.55 (1156)	545 1.70 (1268)	575 1.85 (1380)	600 2.00 (1492)	625 2.15 (1604)	650 2.30 (1716)	680 2.45 (1828)	705 2.55 (1902)	730 2.70 (2014)	755 2.80 (2089)	820 3.25 (2425)
7500 (3540)	530 1.70 (1268)	555 1.85 (1380)	585 2.05 (1529)	615 2.25 (1679)	630 2.30 (1716)	665 2.55 (1902)	685 2.65 (1977)	720 2.80 (2089)	740 2.90 (2163)	770 3.15 (2350)	825 3.60 (2686)
8000 (3775)	540 1.90 (1417)	565 2.15 (1604)	590 2.25 (1679)	625 2.45 (1828)	650 2.65 (1977)	675 2.80 (2089)	705 2.95 (2201)	730 3.05 (2275)	760 3.35 (2499)	785 3.40 (2536)	840 3.95 (2947)
8500 (4010)	555 2.15 (1604)	580 2.30 (1714)	610 2.55 (1902)	630 2.70 (2014)	665 2.90 (2163)	690 3.10 (2313)	720 3.20 (2387)	745 3.35 (2499)	775 3.60 (2686)	805 3.80 (2835)	855 4.40 (3282)
9000 (4245)	565 2.35 (1753)	595 2.60 (1940)	630 2.85 (2126)	655 3.05 (2275)	680 3.20 (2387)	710 3.40 (2536)	735 3.55 (2648)	760 3.75 (2798)	795 4.00 (2894)	820 4.20 (3133)	870 4.70 (3506)
9500 (4485)	585 2.65 (1977)	620 2.95 (2201)	640 3.15 (2350)	670 3.05 (2275)	700 3.55 (2648)	730 3.75 (2798)	755 3.90 (2909)	785 4.15 (3096)	815 4.40 (3282)	840 4.65 (3469)	890 5.15 (3842)
10,000 (4720)	610 3.05 (2275)	635 3.30 (2462)	660 3.45 (2574)	690 3.30 (2462)	720 3.90 (2909)	750 4.10 (3059)	775 4.35 (3245)	805 4.55 (3394)	835 4.85 (3618)	860 5.15 (3842)	----
10,500 (4955)	625 3.35 (2499)	655 3.55 (2648)	685 3.80 (2835)	715 4.05 (3021)	745 4.30 (3208)	775 4.60 (3432)	800 4.75 (3544)	830 5.05 (3767)	860 5.40 (4028)	880 5.70 (4252)	----

NOTE — All data is measured external to the unit with air filters in place.

### SUPPLY AIR PLENUM AND GRILLE AIR THROW DATA

Blower Coil and Supply Plenum and Grille Model Number	Air Volume		*Effective Throw — ft. (m)	
			†10 ft. (3.0 m) Ceiling	
	cfm	L/s	Front of Unit	45° From Unit
†CB17-95V With SPG17-95 or CBH17-95V With SPGH17-95	2000	945	40 (12.2)	31 (9.4)
	2500	1180	46 (14.0)	36 (11.0)
	3000	1415	53 (16.2)	41 (12.5)
	3500	1650	56 (17.1)	45 (13.7)
	4000	1890	63 (19.2)	50 (15.2)
†CB17-135V With SPG17-135 or CBH17-135V With SPGH17-135	3000	1415	50 (15.2)	35 (10.7)
	3500	1650	55 (16.8)	40 (12.2)
	4000	1890	61 (18.6)	44 (13.4)
	4500	2125	67 (20.4)	50 (15.2)
	5000	2360	71 (21.6)	56 (17.1)
†CB17-185V With SPG17-185/275 or CBH17-185V With SPGH17-185/275	5500	2595	74 (22.6)	61 (18.6)
	5000	2360	30 (9.1)	19 (5.8)
	5500	2595	31 (9.4)	19 (5.8)
	6000	2830	35 (10.7)	22 (6.7)
	6500	3070	36 (11.0)	22 (6.7)
	7000	3305	36 (11.0)	22 (6.7)
†CB17-275V With SPG17-185/275 or CBH17-275V With SPGH17-185/275	7500	3540	39 (11.9)	24 (7.3)
	8000	3775	41 (12.5)	26 (7.9)
	6500	3070	36 (11.0)	22 (6.7)
	7000	3305	36 (11.0)	22 (6.7)
	7500	3540	39 (11.9)	24 (7.3)
	8000	3775	41 (12.5)	26 (7.9)
	8500	4010	43 (13.1)	27 (8.2)
	9000	4250	46 (14.0)	29 (8.8)
9500	4485	49 (14.9)	30 (9.1)	
10,000	4720	53 (16.2)	33 (10.1)	
10,500	4955	55 (16.8)	34 (10.4)	

\*Effective throw is terminated at a point where conditioned air reaches a level of 3 feet (1 m) above the floor or where velocity has decreased to 50 feet per minute (0.25 m/s).

†Ceiling height not applicable to CB17 Up-Flow models.

**DIMENSIONS — inches (mm)**

**CB17-95V AND CB17-135V HORIZONTAL MODELS**

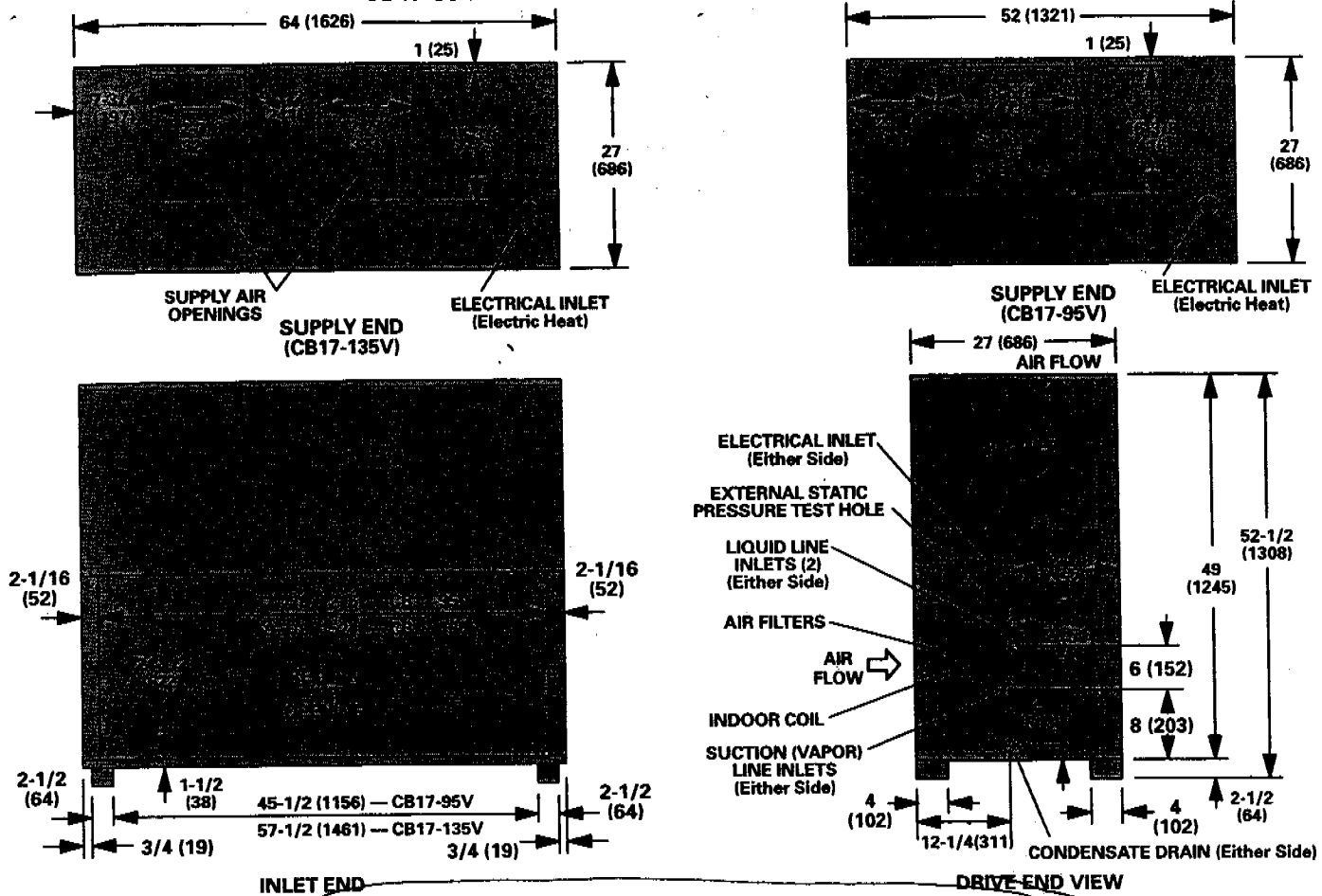

**CB17-185V AND CB17-275V HORIZONTAL MODELS**

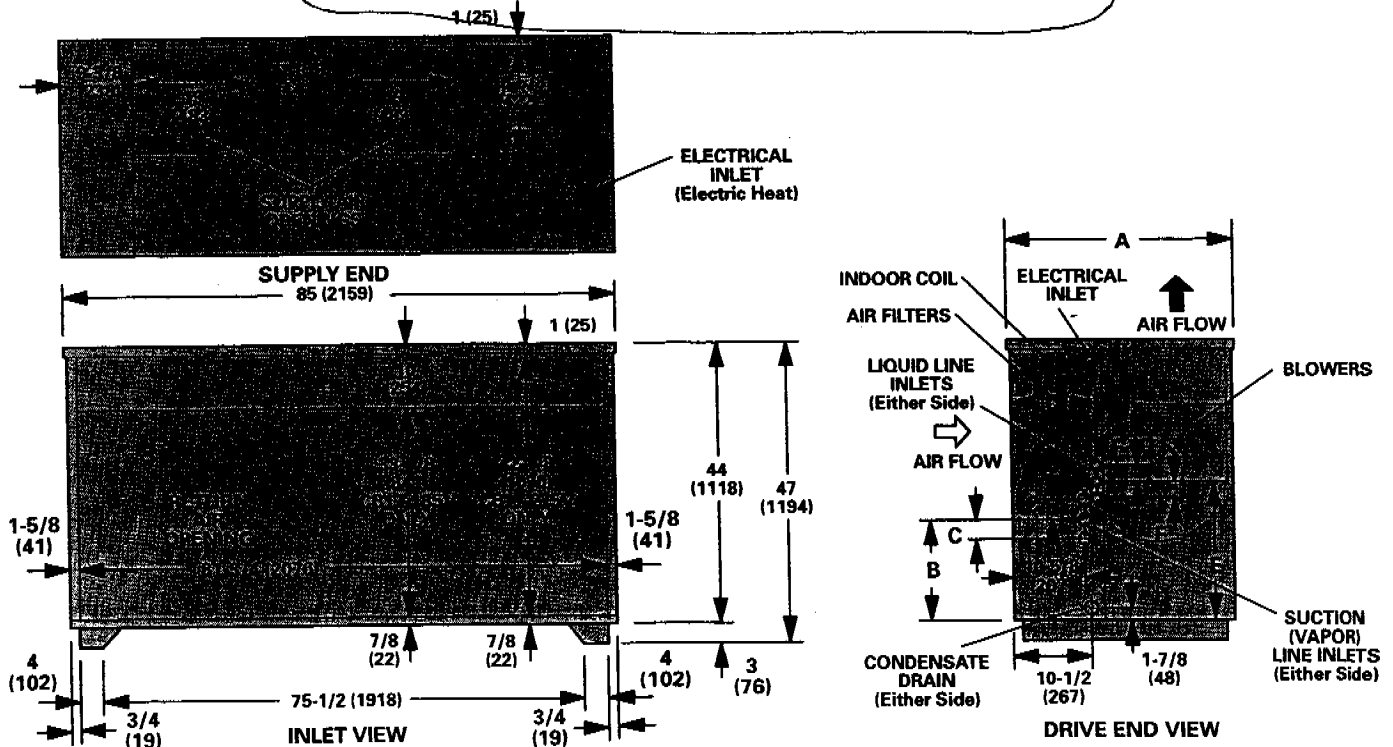

Model No.	A		B		C		D		E		F	
	in.	mm	in.	mm	in.	mm	in.	mm	in.	mm	in.	mm
CB17-185V	35	889	18-3/8	467	2-1/2	57	12-1/2	318	22-5/8	575	1-1/4	32
CB17-275V	44	1118	22-3/4	578	2-5/8	67	14-1/4	362	22-1/2	572	4-7/8	124

# CIRCO System Balance, Inc.

Contractor License #624117

AIR - HYDRONIC - TEMPERATURE - SOUND - SYSTEM SURVEY  
4100 FLORIN-PERKINS RD. SACRAMENTO, CA. 95826 (916) 387-5100 FAX (916) 387-5101

## AIR BALANCE REPORT

APRIL 20, 2005

PROJECT: INTERSTATE PLACTICS T.I.  
LOCATION: 330 COMMERCE CIRCLE  
SACRAMENTO, CALIFORNIA  
MECHANICAL ENGINEER: SIGMA ENGINEERING  
CONTRACTOR: PARK MECHANICAL

Description: Perform Air Balance on HVAC System after installation  
of new Air Handling Unit # AH-1.

Remarks: Ceiling mounted supply diffuser airflows were measured with an ALNOR  
Flow hood.

Sidewall mounted return air register airflows were measured using a  
DAVIS INSTRUMENTS 6000 series Digital rotating vanes anemometer.

Area Factors (Ak) for return registers was calculated from core dimension  
measurements; with allowances made for blade area.

The Final "As Balanced" conditions of service reflect operation with the  
economizer dampers set to provide the Minimum Outside Air. These data  
are shown as "TEST 2" in this report.

TESTS PERFORMED BY: Matt Murphy

Matt Murphy T.B.E.

# CIRCO System Balance, Inc.

SB JOB# \_\_\_\_\_  
 SECTION 1 PAGE 1  
 DATE 4-20-05

## FAN & OUTLET TEST SHEET

AREA SERVED Interstate Plastics UNIT New AH-1

### MOTOR NAMEPLATE DATA

MFG: EMERSON FR 145T  
 HP 3 V 230 FLA 9.2  
 PH 3 SF 1.75 RPM 1725

### SHEAVE DATA:

DIA 1VP60 SHAFT 7/8"  
 ADJ % MIN FIXED \_\_\_\_\_

### FAN NAMEPLATE DATA

MFG Lowhax  
 MODEL # CB-H17-275  
 TYPE 2-DWOL IFC, Centrifugal  
 SIZE \_\_\_\_\_

### SHEAVE DATA:

DIA 1BK124 SHAFT 1 3/16"  
 BELTS 1-B53

DATA	TEST 1	TEST 2	TEST 3
VOLTS	240	240	
AMPS	4.8/6.6/6.7	7.2/7.3/7.2	
B.H.P.	2.18	2.36	
R.P.M.	562	598	
S.P. -	0.66	0.64	
S.P. +	0.26	0.30	
T.S.P.	0.92	0.99	
FILTER S.P.	0.22	0.22	
CFM TOTAL	8540	9315	
CFM R.A.	7212	7564	
CFM O.A.	1328	1751	

### FAN DESIGN DATA

CFM 9000 SP 0.75 RPM \_\_\_\_\_ BHP \_\_\_\_\_  
 MIN. O.A. 1350

ROOM	OPENING			FACTOR	DESIGN		TEST 1		TEST 2		TEST 3		
	NO.	TYPE	SIZE		FPM	CFM	FPM	CFM	FPM	CFM	FPM	CFM	
					SUPPLY								
General	1	CD	12" Dia	1.0	400		700		420				
Office	2						560		400				
	3						750		430				
	4						400		410				
	5						160		440				
	6		14" Dia		1330		1100		1390				
	7		12" Dia		550		650		570				
	8						750		550				
Office	9		14" Dia		300		600		310				
Gen	10				1400		720		1400				
Office	11						680		1980				
	12						340		1440				
	13		8x8				120		75				
							9000		8540				
					Return								
Gen	R1	SR	48x24	7.17	5200		694	4976	716	5134			
Office	R2	S	48x24		1200		162	1161	174	1247			
	R3	S	48x24		1200		150	1073	165	1183			

REMARKS: \_\_\_\_\_ 7600 7212 7564



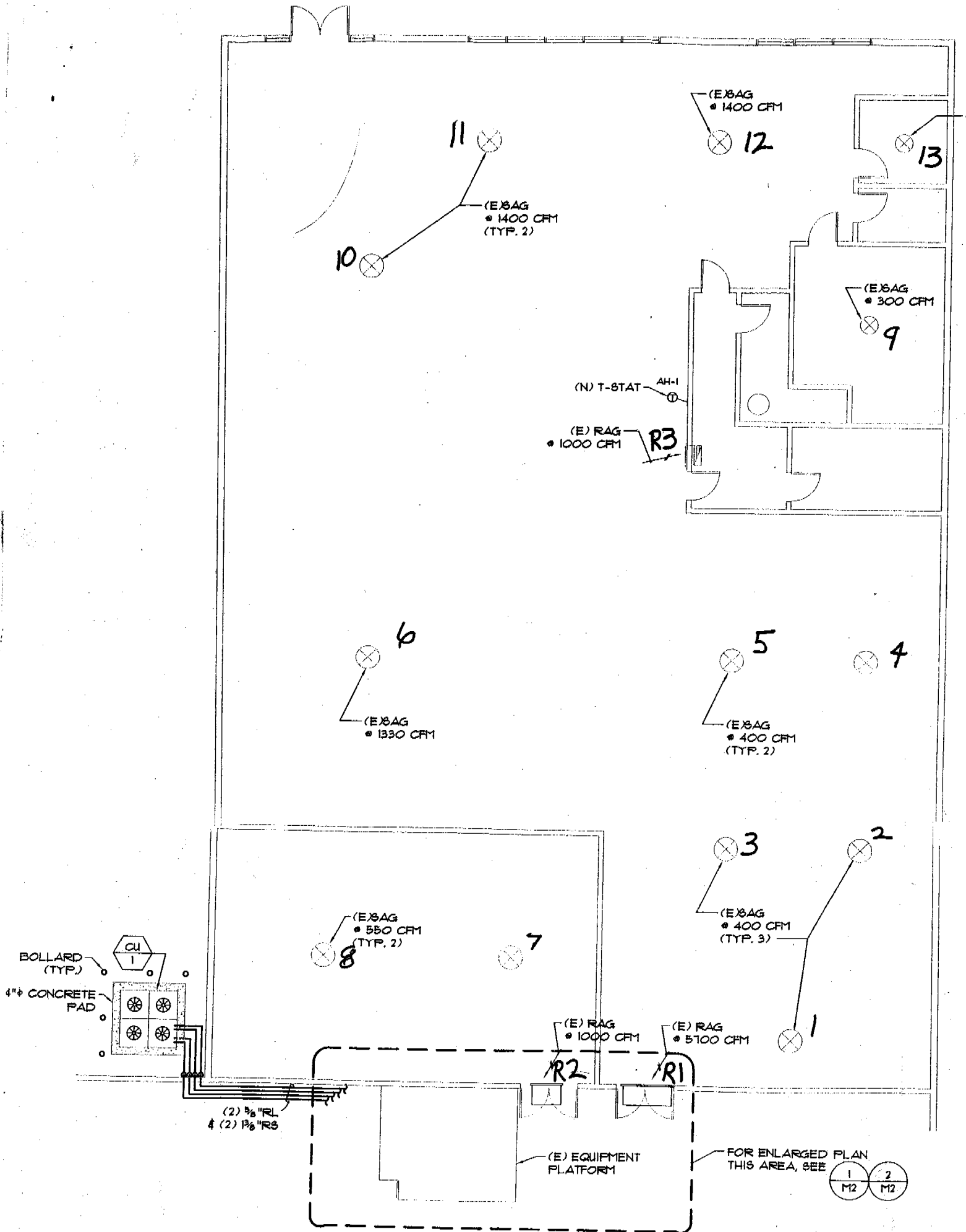

# APPLICATION FOR COMMERCIAL BUILDING PERMIT

**CITY OF SACRAMENTO  
DEVELOPMENT SERVICES DIVISION  
PERMIT SERVICES SECTION**  
1231 I Street, Rm. 200  
Sacramento, CA 95814 (916) 264-7619 FAX: 264-7046

<b>ACTIVITY #</b> <span style="font-size: 1.5em; font-family: cursive;">0503506</span>	<b>Insp. Area</b> <span style="font-size: 1.5em; font-family: cursive;">4C</span>
---	--

Applicant **MUST** complete ALL Unshaded Areas

**ADDRESS:** 330 COMMERCE CIRCLE Suite: \_\_\_\_\_

**PARCEL #:** 275-0251-004-0000

<p style="text-align: center;"><b>CONTACT</b></p> <p>Name: <u>COREY HATANAKA</u> Street Address: <u>7975 RAMONA AVE</u> City/State/Zip: <u>SACRAMENTO, CA 95826</u> Phone: <u>(916) 452-5557 (CELL) (916) 997-7216</u> E-Mail: <u>COREY@PARKMECHANICAL.COM</u></p>	<p style="text-align: center;"><b>LICENSED CONTRACTOR</b> Lic No. # <u>335561</u></p> <p>Name: <u>PARK MECHANICAL, INC</u> Street Address: <u>7975 RAMONA AVE</u> City/State/Zip: <u>SACRAMENTO, CA 95826</u> Phone: <u>(916) 452-5557</u> E-Mail: <u>INFD@PARKMECHANICAL.COM</u></p>
<p style="text-align: center;"><b>ARCHITECT/ENGINEER</b></p> <p>Name: <u>SIGMA ENGINEERING</u> Street Address: <u>3517 MARCONI AVE STE. 204</u> City/State/Zip: <u>SACRAMENTO, CA 95821</u> Phone: <u>(916) 483-7343</u> E-Mail: <u>SIGMAENG@EARTHLINK-NET</u></p>	<p style="text-align: center;"><b>OWNER</b></p> <p>Name: <u>GALEN KLOKKEVOLD TRUST</u> Street Address: <u>330 COMMERCE CIRCLE</u> City/State/Zip: <u>SACRAMENTO, CA 95815</u> Phone: <u>(916) 422-3110</u> E-Mail: _____</p>

⇒ Will permittee have any employees on the jobsite?  No  Yes ⇒ Insurance Co.: STATE FUND

⇒ WORKER'S COMPANSATION POLICY # 1759244-2004 EXPIRATION DATE: 10/1/05

**NATURE OF WORK IN DETAIL:**  
20 TON AIR CONDITIONING CHANGE OUT

**OCCUPANT/TENANT:** \_\_\_\_\_ **VALUATION:** \$59,027.00

FLOOD STATUS:			S.C.A.T.							
JOB DISCRPTION	BLDG	SHELL	APT	TI ( )	REM ( )	SW	FIRE	ADD	OTH	
INSPECTION DISCIPLINES			BLDG	MECH	PLUMB	ELEC		SITE	FIRE	
# Stories	1 <sup>st</sup> Flr Area	Total Area	Use Zone	Deep Group	Condit type	Fire Req. Y / N		Fed Code	Vio. [H]	
						SPR	ALARM		File [Quad]	
B	L	P	M	E	F	S		D	PW UTIL	

**COMMENTS:**  
\_\_\_\_\_  
\_\_\_\_\_

**REGIONAL SANITATION FEES?**  Yes  No      **HEALTH DEPARTMENT:**  Yes  No

**WATER FLOW TEST FOR NEW BUILDINGS OR ADDITIONS?**  Provided  Faxed

**HS29**

6 to 20 Ton (21.1 to 70.3 kW)

Cooling Capacity - 61,000 to 240,000 Btuh (17.8 to 70.3 kW)

Bulletin No. 210307  
December 2000



CERTIFICATION APPLIES ONLY  
WHEN THE COMPLETE  
SYSTEM IS LISTED  
WITH AHRI



CERTIFICATION APPLIES ONLY  
WHEN THE COMPLETE  
SYSTEM IS LISTED  
WITH AHRI

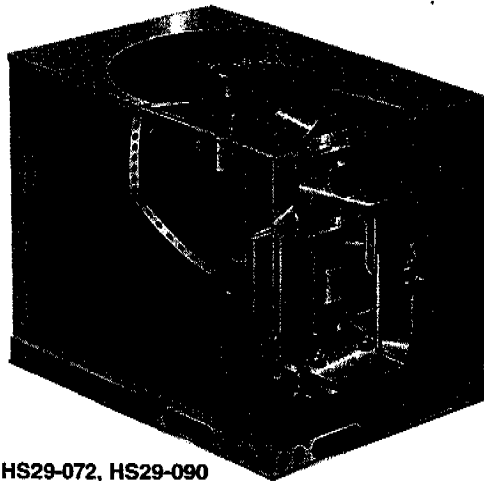
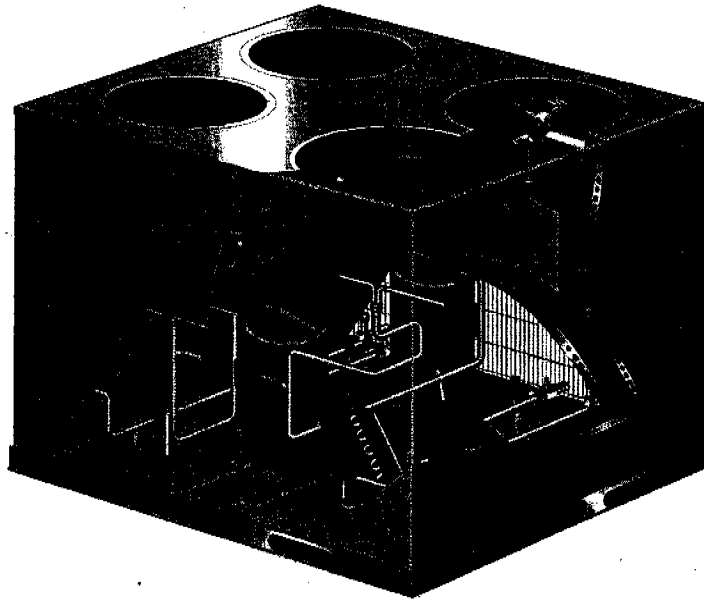

HS29-072, HS29-090

HS29-180, HS29-240

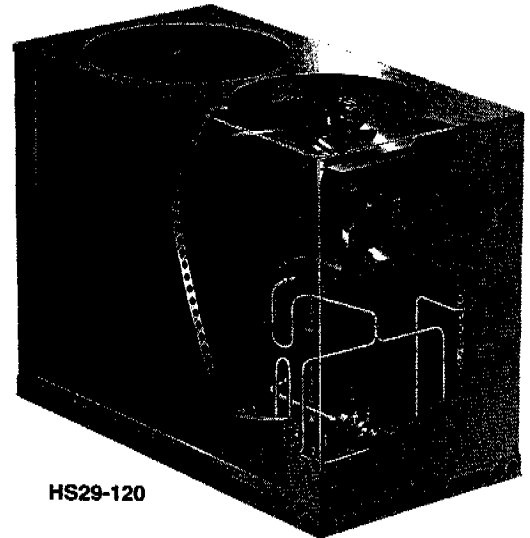

HS29-120

**Typical Applications**

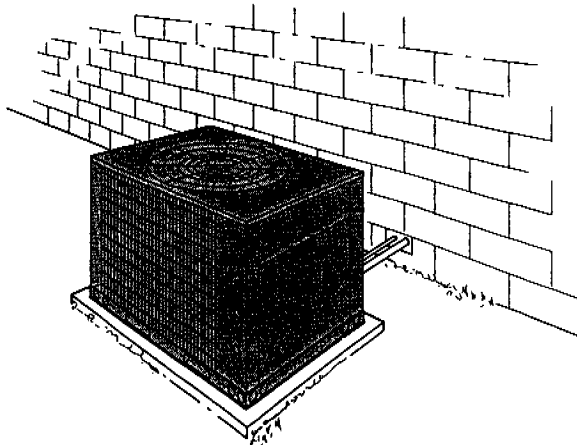

Unit on a slab at grade level

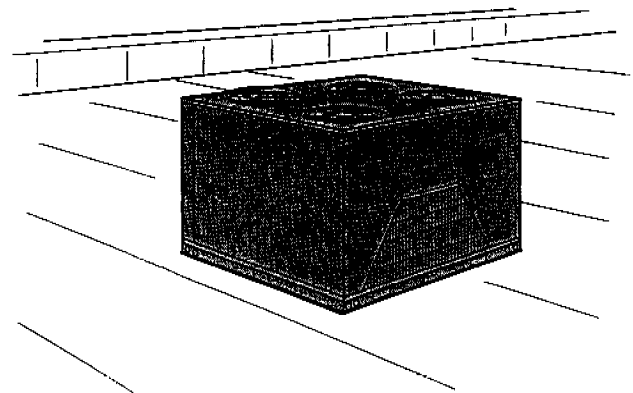

Rooftop Installation

NOTE - Due to Lennox' ongoing commitment to quality, Specifications, Ratings and Dimensions subject to change without notice and without incurring liability. Improper installation, adjustment, alteration, service or maintenance can cause property damage or personal injury. Installation and service must be performed by a qualified installer and servicing agency.

# DIMENSIONS - HS29-180 & HS29-240

## CORNER WEIGHT

Model No.	AA		BB		CC		DD	
	lbs.	kg	lbs.	kg	lbs.	kg	lbs.	kg
HS29-180	232	105	227	103	227	103	232	105
HS29-240	287	130	287	130	268	122	268	122

## CENTER OF GRAVITY

Model No.	EE		FF	
	inch	mm	inch	mm
HS29-180	29-1/4	743	33-1/4	845
HS29-240	28-1/2	724	33-1/4	845

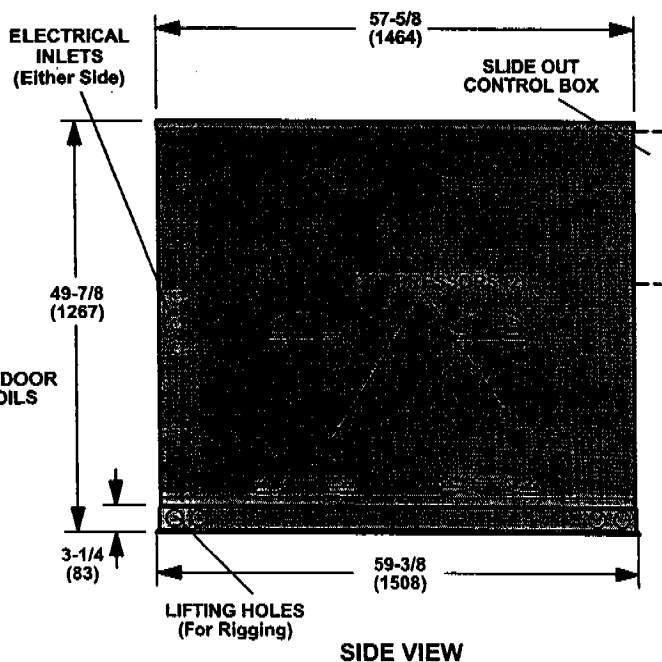
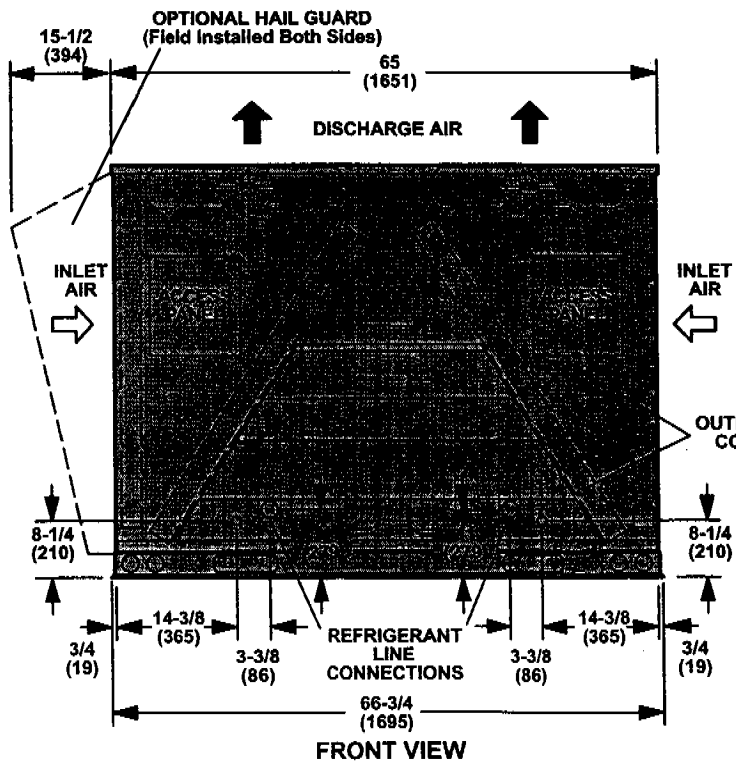
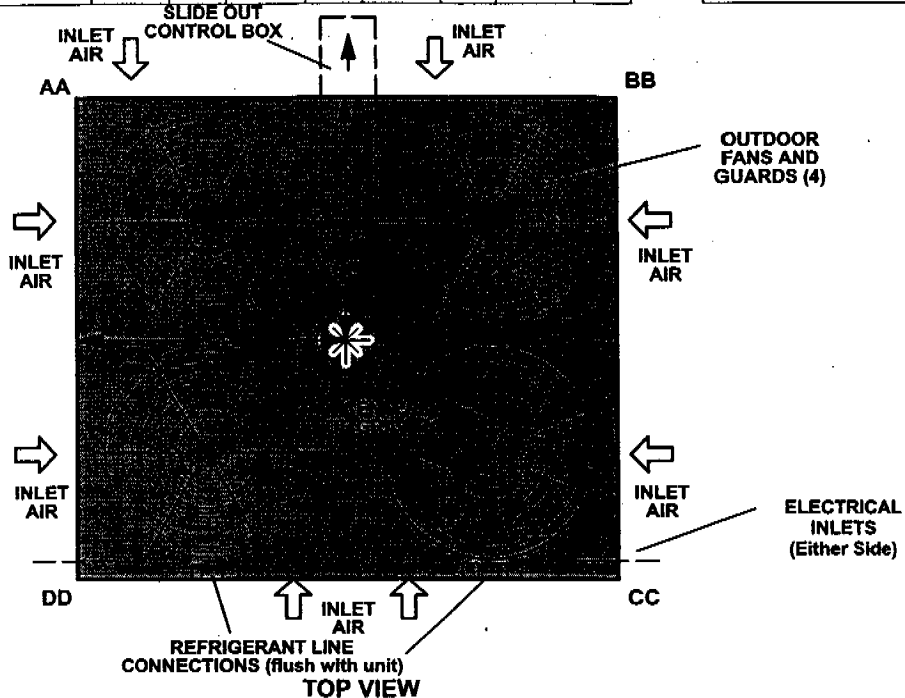

# COOLING RATINGS

NOTE - For Temperatures and Capacities not shown in tables, see bulletin - Cooling Unit Rating Table Correction Factor Data in Miscellaneous Engineering Data section. All values are gross capacities and do not include evaporator coil blower motor heat deduction.

## HS29-240 — CB17/CBH17-275 COOLING CAPACITY - ONE COMPRESSOR OPERATING

Entering Wet Bulb Temperature	Total Air Volume		Outdoor Air Temperature Entering Outdoor Coil																							
			65°F (18°C)						75°F (24°C)						85°F (29°C)						95°F (35°C)					
			Total Cooling Capacity		Comp Motor kW Input	Sensible To Total Ratio (S/T)			Total Cooling Capacity		Comp Motor kW Input	Sensible To Total Ratio (S/T)			Total Cooling Capacity		Comp Motor kW Input	Sensible To Total Ratio (S/T)			Total Cooling Capacity		Comp Motor kW Input	Sensible To Total Ratio (S/T)		
						Dry Bulb						Dry Bulb						Dry Bulb						Dry Bulb		
cfm	L/s	kBtuh	kW	75°F 24°C	80°F 27°C	85°F 29°C	kBtuh	kW	Input	75°F 24°C	80°F 27°C	85°F 29°C	kBtuh	kW	Input	75°F 24°C	80°F 27°C	85°F 29°C	kBtuh	kW	Input	75°F 24°C	80°F 27°C	85°F 29°C		
63°F (17°C)	6400	3020	124.3	36.4	7.46	.67	.81	.93	120.8	35.4	8.21	.68	.82	.94	117.1	34.3	9.07	.69	.83	.96	113.1	33.1	10.03	.70	.84	.97
	8000	3775	129.3	37.9	7.58	.72	.88	.99	125.6	36.8	8.33	.73	.89	1.00	121.7	35.7	9.18	.74	.90	1.00	117.6	34.5	10.15	.75	.92	1.00
	9600	4530	133.3	39.1	7.66	.77	.94	1.00	129.6	38.0	8.42	.78	.95	1.00	125.6	36.8	9.27	.80	.97	1.00	121.4	35.6	10.24	.81	.98	1.00
67°F (19°C)	6400	3020	132.3	38.8	7.63	.59	.65	.77	128.5	37.7	8.38	.54	.66	.78	124.5	36.5	9.23	.54	.66	.79	120.2	35.2	10.21	.55	.67	.81
	8000	3775	136.8	40.1	7.74	.56	.70	.84	132.8	38.9	8.48	.56	.70	.86	128.5	37.7	9.33	.57	.72	.87	124.0	36.3	10.29	.58	.73	.89
	9600	4530	140.0	41.0	7.81	.59	.75	.91	135.9	39.8	8.55	.59	.76	.92	131.5	38.5	9.40	.60	.77	.94	126.8	37.2	10.37	.61	.79	.96
71°F (22°C)	6400	3020	141.1	41.4	7.83	.41	.51	.62	137.1	40.2	8.58	.41	.52	.63	132.7	38.9	9.43	.41	.52	.64	128.1	37.5	10.41	.41	.53	.65
	8000	3775	145.6	42.7	7.93	.41	.54	.67	141.3	41.4	8.68	.41	.55	.68	136.7	40.1	9.53	.42	.56	.69	131.8	38.6	10.60	.42	.56	.71
	9600	4530	148.6	43.6	8.01	.42	.57	.72	144.2	42.3	8.75	.43	.58	.74	139.4	40.9	9.60	.43	.59	.75	134.3	39.4	10.57	.43	.60	.77

## HS29-240 — CB17/CBH17-275 COOLING CAPACITY - BOTH COMPRESSORS OPERATING

Entering Wet Bulb Temperature	Total Air Volume		Outdoor Air Temperature Entering Outdoor Coil																							
			85°F (29°C)						95°F (35°C)						105°F (41°C)						115°F (46°C)					
			Total Cooling Capacity		Comp Motor kW Input	Sensible To Total Ratio (S/T)			Total Cooling Capacity		Comp Motor kW Input	Sensible To Total Ratio (S/T)			Total Cooling Capacity		Comp Motor kW Input	Sensible To Total Ratio (S/T)			Total Cooling Capacity		Comp Motor kW Input	Sensible To Total Ratio (S/T)		
						Dry Bulb						Dry Bulb						Dry Bulb						Dry Bulb		
cfm	L/s	kBtuh	kW	Input	75°F 24°C	80°F 27°C	85°F 29°C	kBtuh	kW	Input	75°F 24°C	80°F 27°C	85°F 29°C	kBtuh	kW	Input	75°F 24°C	80°F 27°C	85°F 29°C	kBtuh	kW	Input	75°F 24°C	80°F 27°C	85°F 29°C	
63°F (17°C)	6400	3020	233.4	68.4	18.40	.72	.85	.96	225.5	66.1	20.37	.73	.86	.97	217.0	63.6	22.62	.74	.88	.98	207.9	60.9	25.23	.75	.90	.99
	8000	3775	242.6	71.1	18.62	.77	.92	1.00	234.5	68.7	20.60	.78	.93	1.00	225.7	66.1	22.86	.80	.95	1.00	216.4	63.4	25.45	.81	.96	1.00
	9600	4530	250.4	73.4	18.80	.82	.97	1.00	242.1	71.0	20.78	.83	.98	1.00	233.5	68.4	23.06	.85	.99	1.00	224.1	65.7	25.67	.87	.99	1.00
67°F (19°C)	6400	3020	247.9	72.7	18.72	.56	.69	.82	239.4	70.2	20.71	.57	.70	.83	230.2	67.5	22.95	.58	.72	.85	220.3	64.6	25.56	.58	.73	.87
	8000	3775	255.9	75.0	18.92	.59	.75	.89	247.0	72.4	20.88	.60	.76	.90	237.3	69.5	23.16	.61	.77	.92	226.8	66.5	25.78	.62	.79	.94
	9600	4530	261.8	76.7	19.06	.63	.80	.94	252.5	74.0	21.04	.64	.81	.96	242.5	71.1	23.33	.65	.83	.97	231.9	68.0	25.93	.66	.85	.98
71°F (22°C)	6400	3020	264.3	77.5	19.11	.43	.55	.67	255.2	74.8	21.11	.43	.55	.68	245.4	71.9	23.39	.43	.56	.69	234.7	68.8	25.98	.43	.57	.70
	8000	3775	272.1	79.7	19.31	.44	.58	.72	262.5	76.9	21.29	.44	.59	.74	252.1	73.9	23.57	.44	.60	.75	240.9	70.6	26.17	.45	.61	.77
	9600	4530	277.4	81.3	19.45	.45	.62	.78	267.4	78.4	21.43	.45	.63	.79	256.8	75.3	23.69	.46	.64	.81	245.2	71.9	26.32	.46	.65	.83

## HS29-240 — (TWO) CB17/CBH17-135 COOLING CAPACITY - ONE COMPRESSOR OPERATING

Entering Wet Bulb Temperature	Total Air Volume		Outdoor Air Temperature Entering Outdoor Coil																							
			65°F (18°C)						75°F (24°C)						85°F (29°C)						95°F (35°C)					
			Total Cooling Capacity		Comp Motor kW Input	Sensible To Total Ratio (S/T)			Total Cooling Capacity		Comp Motor kW Input	Sensible To Total Ratio (S/T)			Total Cooling Capacity		Comp Motor kW Input	Sensible To Total Ratio (S/T)			Total Cooling Capacity		Comp Motor kW Input	Sensible To Total Ratio (S/T)		
						Dry Bulb						Dry Bulb						Dry Bulb						Dry Bulb		
cfm	L/s	kBtuh	kW	Input	75°F 24°C	80°F 27°C	85°F 29°C	kBtuh	kW	Input	75°F 24°C	80°F 27°C	85°F 29°C	kBtuh	kW	Input	75°F 24°C	80°F 27°C	85°F 29°C	kBtuh	kW	Input	75°F 24°C	80°F 27°C	85°F 29°C	
63°F (17°C)	3200	1510	120.2	35.2	7.40	.71	.84	.96	116.8	34.2	8.15	.72	.85	.97	113.2	33.2	8.96	.73	.86	.98	109.3	32.0	9.94	.74	.88	.99
	4000	1890	125.0	36.6	7.52	.76	.90	1.00	121.4	35.6	8.25	.77	.92	1.00	117.5	34.4	9.09	.78	.93	1.00	113.5	33.3	10.05	.79	.95	1.00
	4800	2285	128.7	37.7	7.60	.81	.96	1.00	124.9	36.8	8.35	.82	.97	1.00	121.1	35.5	9.18	.83	.99	1.00	117.0	34.3	10.13	.85	1.00	1.00
67°F (19°C)	3200	1510	127.9	37.5	7.58	.57	.69	.81	124.2	36.4	8.31	.57	.70	.82	120.2	35.2	9.15	.57	.70	.83	116.0	34.0	10.10	.58	.71	.84
	4000	1890	132.2	38.7	7.68	.59	.74	.87	128.2	37.8	8.41	.60	.75	.89	124.1	36.4	9.24	.60	.76	.90	119.6	35.1	10.20	.61	.77	.92
	4800	2285	135.2	39.6	7.75	.62	.78	.93	131.1	38.4	8.48	.63	.80	.95	126.8	37.2	9.32	.64	.81	.96	122.2	35.8	10.28	.64	.83	.98
71°F (22°C)	3200	1510	136.3	39.9	7.77	.43	.55	.66	132.3	38.8	8.51	.43	.55	.67	128.1	37.5	9.35	.43	.56	.68	123.6	36.2	10.31	.43	.56	.69
	4000	1890	140.5	41.2	7.88	.44	.58	.71	136.3	39.9	8.61	.44	.58	.72	131.8	38.6	9.45	.44	.59	.73	127.1	37.2	10.40	.45	.60	.75
	4800	2285	143.4	42.0	7.95	.45	.61	.76	139.0	40.7	8.68	.45	.61	.77	134.4	39.4	9.51	.46	.62	.79	129.4	37.9	10.47	.46	.63	.80

## HS29-240 — (TWO) CB17/CBH17-135 COOLING CAPACITY - BOTH COMPRESSORS OPERATING

Entering Wet Bulb Temperature	Total Air Volume		Outdoor Air Temperature Entering Outdoor Coil																							
			85°F (29°C)						95°F (35°C)						105°F (41°C)						115°F (46°C)					
			Total Cooling Capacity		Comp Motor kW Input	Sensible To Total Ratio (S/T)			Total Cooling Capacity		Comp Motor kW Input	Sensible To Total Ratio (S/T)			Total Cooling Capacity		Comp Motor kW Input	Sensible To Total Ratio (S/T)			Total Cooling Capacity		Comp Motor kW Input	Sensible To Total Ratio (S/T)		
						Dry Bulb						Dry Bulb						Dry Bulb						Dry Bulb		
cfm	L/s	kBtuh	kW	Input	75°F 24°C	80°F 27°C	85°F 29°C	kBtuh	kW	Input	75°F 24°C	80°F 27°C	85°F 29°C	kBtuh	kW	Input	75°F 24°C	80°F 27°C	85°F 29°C	kBtuh	kW	Input	75°F 24°C	80°F 27°C	85°F 29°C	
63°F (17°C)	6400	3020	226.4	66.4	17.94	.73	.86	.98	218.6	64.1	19.66	.74	.88	.99	210.2	61.6	22.04	.75	.89	1.00	201.0	58.9	24.56	.76	.91	1.00
	8000	3775	235.0	68.9	18.16	.78	.93	1.00	226.8	66.5	20.08	.79	.95	1.00	218.2	63.9	22.26	.81	.96	1.00	209.0	61.3	24.76	.82	.98	1.00
	9600	4530	242.2	71.0	18.34	.83	.99	1.00	234.0	68.6	20.24	.85	1.00	1.00	225.2	66.0	22.44	.86	1.00	1.00	216.4	63.4	24.98	.88	1.00	1.00
67°F (19°C)	6400	3020	240.4	70.5	18.30	.57	.70	.83	232.0	68.0	20.18	.58	.71	.84	223.0	65.4	22.38	.59	.72	.86	213.0	62.4	24.92	.59	.74	.88
	8000	3775	248.0	72.7	18.46	.60	.76	.90	239.2	70.1	20.38	.61	.77	.92	229.6	67.3	22.60	.62	.79	.93	219.2	64.2	25.10	.63	.80	.96
	9600	4530	253.6	74.3	18.62	.64	.81	.96	244.4	71.6	20.54	.64	.82	.98	234.6	68.8	22.72	.66	.84	.99	224.0	65.6	25.24	.67	.86	1.00
71°F (22°C)	6400	3020	256.0	75.0	18.68	.43	.56	.68	247.0	72.4	20.60	.43	.56	.69	237.4	69.6	22.78	.44	.57	.70	227.0	66.5	25.32	.44	.58	.71
	8000	3775	263.6	77.3	18.88	.44	.59	.73	254.0	74.4	20.78	.45	.60	.75	243.8	71.5	23.00	.45	.61	.76	232.8	68.2	25.56	.45	.62	.78
	9600	4530	268.6	78.7	19.02	.46	.62	.79	258.8	75.8	20.92	.46	.63	.80	248.2	72.7	23.14	.46	.65	.82	237.0					

**CB17 SERIES — UP-FLOW**  
**CBH17 SERIES — HORIZONTAL**  
**BLOWER-COIL-FILTER UNITS**

Bulletin #210070  
August 1997  
Supersedes  
October 1994

\*71,000 to 246,000 Btuh (20.8 to 72.1 kW) Cooling Capacity  
\*85,000 to 232,000 Btuh (24.9 to 68.0 kW) Heat Pump Heating Capacity  
35,500 to 204,800 Btuh (10.4 to 60.0 kW) Optional Electric Heat  
100,000 to 425,000 Btuh (29.3 to 124.5 kW) Optional Hot Water Heat  
\*ARI Certified Ratings

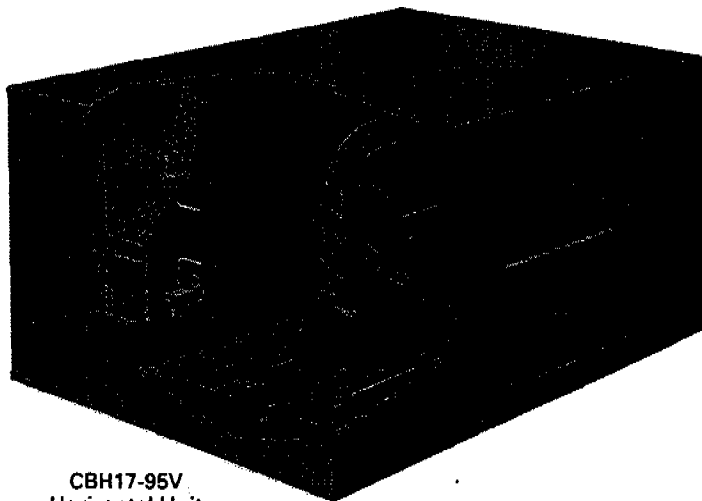

CBH17-95V  
Horizontal Unit

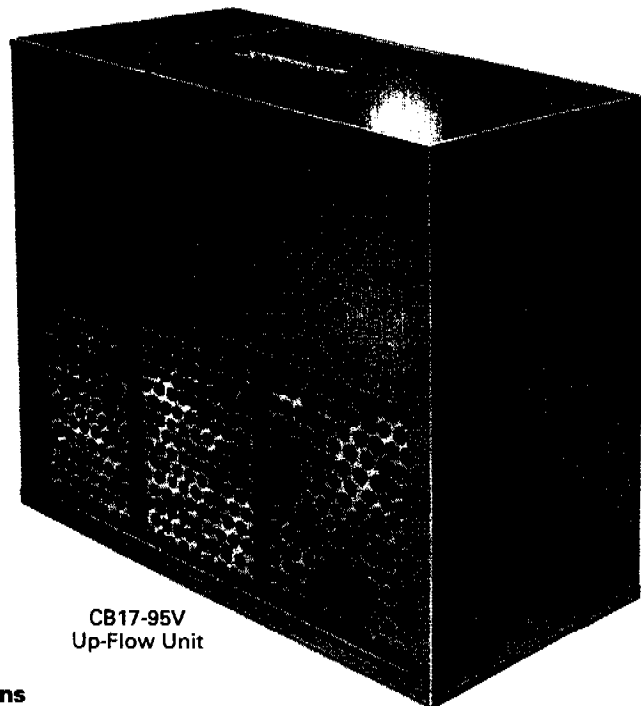

CB17-95V  
Up-Flow Unit

**Typical Applications**

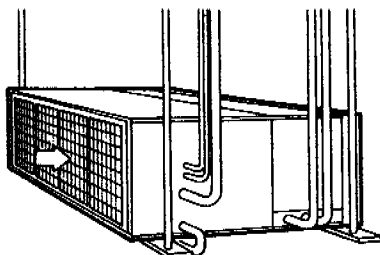

Horizontal Store Installation With  
Optional Hot Water Heat Section and  
Supply Air Plenum and Grille

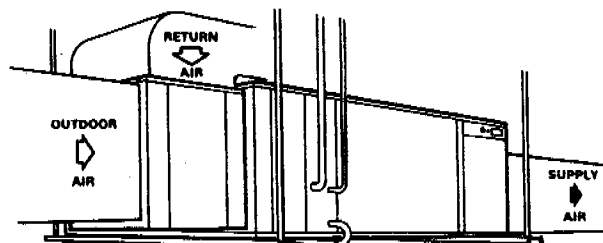

Suspended Horizontal Installation  
With Optional Electric Heat and  
Economizer Dampers

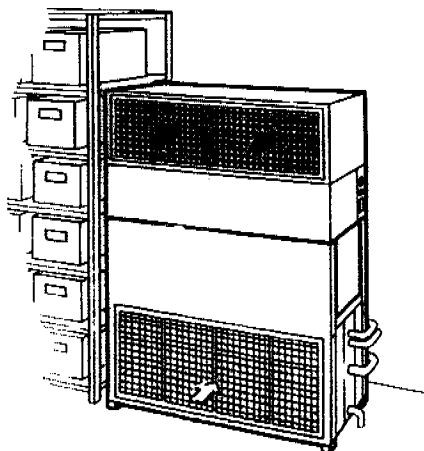

Vertical Store Cooler Installation With  
Optional Electric Heat Section and  
Supply Air Plenum and Grille

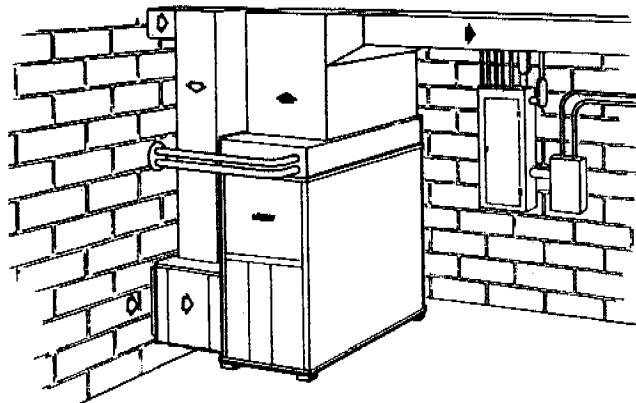

Up-Flow Installation With  
Optional Hot Water Heat Section and  
Economizer Dampers

♣ The maple leaf symbol in this bulletin denotes Canadian only usage where applicable

NOTE — Due to Lennox' ongoing commitment to quality, Specifications, Ratings and Dimensions subject to change without notice and without incurring liability.

# SPECIFICATIONS

Model Number		CB17-95V CBH17-95V	CB17-135V CBH17-135V	CB17-185V CBH17-185V	CB17-275V CBH17-275V	
Nominal Cooling Capacity — Tons (kW)		7-1/2 (26)	10 (35)	15 (53)	20 (70)	
Blower wheel nominal diameter x width — in. (mm)		(1) 15 x 15 (381 x 381)	(2) 15 x 9 (381 x 229)	(2) 15 x 11 (381 x 279)	(2) 15 x 15 (381 x 381)	
Blower motor output and blower drives		See Drive Kit Table (shipped separately)				
*Number and size of air filters	in.	(2) 16 x 25 x 1 (1) 20 x 25 x 1	(4) 16 x 25 x 1	(6) 16 x 20 x 1 (2) 16 x 25 x 1	(6) 20 x 20 x 1 (2) 20 x 25 x 1	
	mm	(2) 406 x 635 x 25 (1) 508 x 635 x 25	(4) 406 x 635 x 25	(6) 406 x 508 x 25 (2) 406 x 635 x 25	(6) 508 x 508 x 25 (2) 508 x 635 x 25	
Condensate drain connection — female pipe thread	in.	(2) 1-1/4	(2) 1-1/4	(2) 1-1/4	(2) 1-1/4	
	mm	(2) 31.8	(2) 31.8	(2) 31.8	(2) 31.8	
Refrigerant		HCFC-22				
Evaporator Coil	Net face area — ft. <sup>2</sup> (m <sup>2</sup> )		7.98 (0.74)	10.07 (0.94)	17.38 (1.61)	23.16 (2.15)
	Coil split — 1st stage/2nd stage (%)		60/40	61.9/38.1	53.8/46.2	52.9/47.1
	Number of rows		4	4	4	4
	Tube outside diameter — in. (mm)		3/8 (9.5)	3/8 (9.5)	1/2 (12.7)	1/2 (12.7)
	Fins per inch (fins per m)		14 (551)	14 (551)	13 (512)	13 (512)
	Suction line connection — outside diameter (sweat)	in.	1-3/8	1-3/8	(2) 1-1/8	(2) 1-3/8
		mm	34.9	34.9	(2) 28.5	(2) 34.9
	Liquid line connection — outside diameter (sweat)	in.	(2) 3/8	(2) 3/8	(2) 1/2	(4) 3/8
mm		(2) 9.5	(2) 9.5	(2) 12.7	(4) 9.5	
**Shipping weight — lbs. (kg) (†2 packages)	Up-flow	350 (159)	418 (190)	720 (327)	815 (370)	
	Horizontal	312 (142)	379 (172)	760 (345)	860 (390)	
◀ Optional Accessories (Must Be Ordered Extra) ▶						
Electric Heat Model Number		EH17-95	EH17-135	EH17-185/275		
Hot Water Coil	Model Number		HW17-95 (41F20)	HW17-135 (41F21)	HW17-185/275 (27G75)	
	Shipping weight — lbs. (kg)		95 (43)	104 (47)	160 (73)	
	††Heating capacity — Btuh (kW)		185,000 (54.2)	257,000 (75.3)	405,000 (118.7)	462,000 (135.4)
	Net face area — ft. <sup>2</sup> (m <sup>2</sup> )		6.4 (0.59)	8.5 (0.79)	15.6 (1.45)	
	Tube outside diameter — in. (mm)		1/2 (12.7)	1/2 (12.7)	1/2 (12.7)	
	number of rows		2	2	2	
	Fins per inch (fins per m)		12 (472)	12 (472)	12 (472)	
Water line connections	Inlet	1-3/8 (35) sweat	1-3/8 (35) sweat	1-5/8 (41) sweat		
	Outlet	1-3/8 (35) sweat	1-3/8 (35) sweat	1-5/8 (41) sweat		
Supply Air Plenum and Grille (shipping weight)	Up-flow	SPG17-95 (68F08) 124 lbs. (56 kg)	SPG17-135 (68F09) 148 lbs. (67 kg)	SPG17-185/275 (25G89) 242 lbs. (110 kg)		
	Horizontal	SPGH17-95 (68F10) 41 lbs. (19 kg)	SPGH17-135 (68F11) 50 lbs. (23 kg)	SPGH17-185/275 (25G88) 86 lbs. (39 kg)		
Return Air Grille (shipping weight)		RG17-95 (68F14) 29 lbs. (13 kg)	RG17-135 (68F15) 37 lbs. (17 kg)	RG17-185 (25G97) 65 lbs. (29 kg)	RG17-275 (25G98) 82 lbs. (37 kg)	
Empty Spacer Cabinet (shipping weight)		CB17-95-00 (50F06) 55 lbs. (25 kg)	CB17-135-00 (50F07) 60 lbs. (27 kg)	CB17-185/275-00 (27G76) 82 lbs. (37 kg)		
Economizer Dampers (shipping weight)		EMD17M-95 (74G20) 145 lbs. (66 kg)	EMD17M-135 (74G21) 185 lbs. (84 kg)	EMD17M-185 (43G63) 395 lbs. (179 kg)	EMD17M-275 (43G64) 542 lbs. (264 kg)	
Differential Enthalpy Control		54G44				
CBH17 Horizontal Suspension Kit (shipping weight)		LB-50866CA (44F93) 21 lbs. (10 kg)	LB-50866CB (44F94) 25 lbs. (11 kg)	Not Available		
Heat Pump Check Valve Kit		LB-51486CA (53F21)	LB-51486CA (53F21)	LB-55674CA (29G19)	LB-51486CB (29G20)	

\*Standard filters are 1 inch (25 mm) thick. 2 inch (51 mm) filters may also be used.

\*\*Weight does not include motor and drives.

†Packages consist of: blower coil unit and drive kit with motor and drives.

††Rated at 180°F (82°C) supply water temperature, 70°F (21°C) entering air temperature, 20°F (11°C) water temperature drop and 450 cfm air volume per ton (60 L/s air volume per kW) of cooling capacity. See Hot Water Capacity Curves for heating capacities at different conditions.

# BLOWER DATA

## CB17-275V AND CBH17-275V BLOWER PERFORMANCE

Air Volume cfm (L/s)	STATIC PRESSURE EXTERNAL TO UNIT — Inches Water Gauge (Pa)										
	0.1 (25)	0.2 (50)	0.3 (75)	0.4 (100)	0.5 (125)	0.6 (150)	0.7 (175)	0.8 (200)	0.9 (225)	1.0 (250)	1.25 (310)
	RPM hp (W)	RPM hp (W)	RPM hp (W)	RPM hp (W)	RPM hp (W)	RPM hp (W)	RPM hp (W)	RPM hp (W)	RPM hp (W)	RPM hp (W)	RPM hp (W)
6500 (3065)	515 1.35 (1007)	535 1.45 (1082)	570 1.70 (1268)	585 1.80 (1343)	615 1.90 (1417)	635 2.00 (1492)	670 2.25 (1679)	690 2.30 (1716)	720 2.45 (1828)	740 2.50 (1865)	805 2.95 (2201)
7000 (3305)	525 1.55 (1156)	545 1.70 (1268)	575 1.85 (1380)	600 2.00 (1492)	625 2.15 (1604)	650 2.30 (1716)	680 2.45 (1828)	705 2.55 (1902)	730 2.70 (2014)	755 2.80 (2089)	820 3.25 (2425)
7500 (3540)	530 1.70 (1268)	555 1.85 (1380)	585 2.05 (1529)	615 2.25 (1679)	630 2.30 (1716)	665 2.55 (1902)	685 2.65 (1977)	720 2.80 (2089)	740 2.90 (2163)	770 3.15 (2350)	825 3.60 (2686)
8000 (3775)	540 1.90 (1417)	565 2.15 (1604)	590 2.25 (1679)	625 2.45 (1828)	650 2.65 (1977)	675 2.80 (2089)	705 2.95 (2201)	730 3.05 (2275)	760 3.35 (2499)	785 3.40 (2536)	840 3.95 (2947)
8500 (4010)	555 2.15 (1604)	580 2.30 (1714)	610 2.55 (1902)	630 2.70 (2014)	665 2.90 (2163)	690 3.10 (2313)	720 3.20 (2387)	745 3.35 (2499)	775 3.60 (2686)	805 3.80 (2835)	855 4.40 (3282)
9000 (4245)	565 2.35 (1753)	595 2.60 (1940)	630 2.85 (2126)	655 3.05 (2275)	680 3.20 (2387)	710 3.40 (2536)	735 3.55 (2648)	760 3.75 (2798)	795 4.00 (2894)	820 4.20 (3133)	870 4.70 (3506)
9500 (4485)	585 2.65 (1977)	620 2.95 (2201)	640 3.15 (2350)	670 3.05 (2275)	700 3.55 (2648)	730 3.75 (2798)	755 3.90 (2909)	785 4.15 (3096)	815 4.40 (3282)	840 4.65 (3469)	890 5.15 (3842)
10,000 (4720)	610 3.05 (2275)	635 3.30 (2462)	660 3.45 (2574)	690 3.30 (2462)	720 3.90 (2909)	750 4.10 (3059)	775 4.35 (3245)	805 4.55 (3394)	835 4.85 (3618)	860 5.15 (3842)	----
10,500 (4955)	625 3.35 (2499)	655 3.55 (2648)	685 3.80 (2835)	715 4.05 (3021)	745 4.30 (3208)	775 4.60 (3432)	800 4.75 (3544)	830 5.05 (3767)	860 5.40 (4028)	880 5.70 (4252)	----

NOTE — All data is measured external to the unit with air filters in place.

## SUPPLY AIR PLENUM AND GRILLE AIR THROW DATA

Blower Coil and Supply Plenum and Grille Model Number	Air Volume		*Effective Throw — ft. (m)	
			†10 ft. (3.0 m) Ceiling	
	cfm	L/s	Front of Unit	45° From Unit
†CB17-95V With SPG17-95 or CBH17-95V With SPGH17-95	2000	945	40 (12.2)	31 (9.4)
	2500	1180	46 (14.0)	36 (11.0)
	3000	1415	53 (16.2)	41 (12.5)
	3500	1650	56 (17.1)	45 (13.7)
	4000	1890	63 (19.2)	50 (15.2)
†CB17-135V With SPG17-135 or CBH17-135V With SPGH17-135	3000	1415	50 (15.2)	35 (10.7)
	3500	1650	55 (16.8)	40 (12.2)
	4000	1890	61 (18.6)	44 (13.4)
	4500	2125	67 (20.4)	50 (15.2)
	5000	2360	71 (21.6)	56 (17.1)
†CB17-185V With SPG17-185/275 or CBH17-185V With SPGH17-185/275	5500	2595	74 (22.6)	61 (18.6)
	5000	2360	30 (9.1)	19 (5.8)
	5500	2595	31 (9.4)	19 (5.8)
	6000	2830	35 (10.7)	22 (6.7)
	6500	3070	36 (11.0)	22 (6.7)
†CB17-275V With SPG17-185/275 or CBH17-275V With SPGH17-185/275	7000	3305	36 (11.0)	22 (6.7)
	7500	3540	39 (11.9)	24 (7.3)
	8000	3775	41 (12.5)	26 (7.9)
	6500	3070	36 (11.0)	22 (6.7)
	7000	3305	36 (11.0)	22 (6.7)
	7500	3540	39 (11.9)	24 (7.3)
	8000	3775	41 (12.5)	26 (7.9)
	8500	4010	43 (13.1)	27 (8.2)
9000	4250	46 (14.0)	29 (8.8)	
9500	4485	49 (14.9)	30 (9.1)	
10,000	4720	53 (16.2)	33 (10.1)	
10,500	4955	55 (16.8)	34 (10.4)	

\*Effective throw is terminated at a point where conditioned air reaches a level of 3 feet (1 m) above the floor or where velocity has decreased to 50 feet per minute (0.25 m/s).

†Ceiling height not applicable to CB17 Up-Flow models.

**DIMENSIONS — inches (mm)**

**CB17-95V AND CB17-135V HORIZONTAL MODELS**

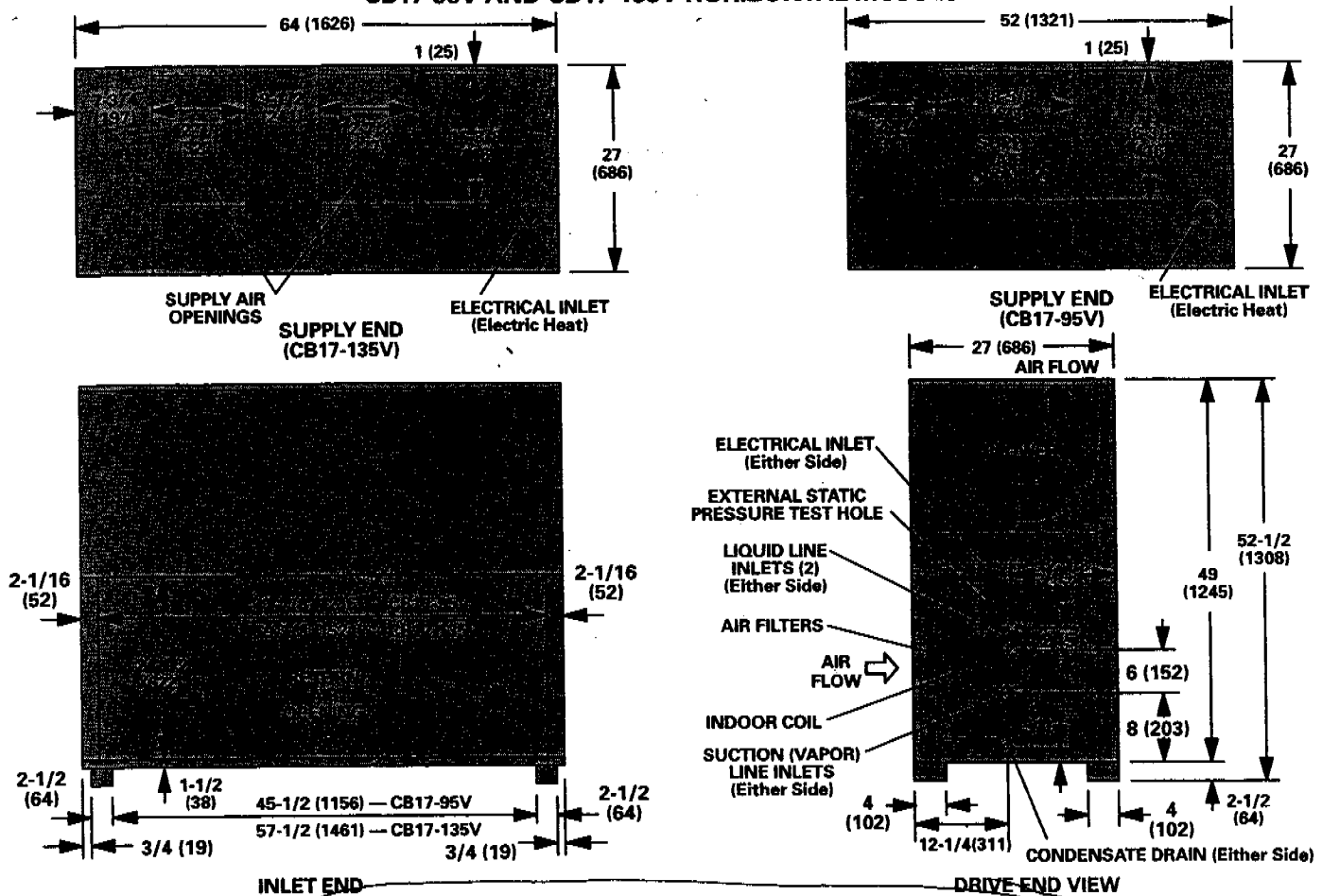

**CB17-185V AND CB17-275V HORIZONTAL MODELS**

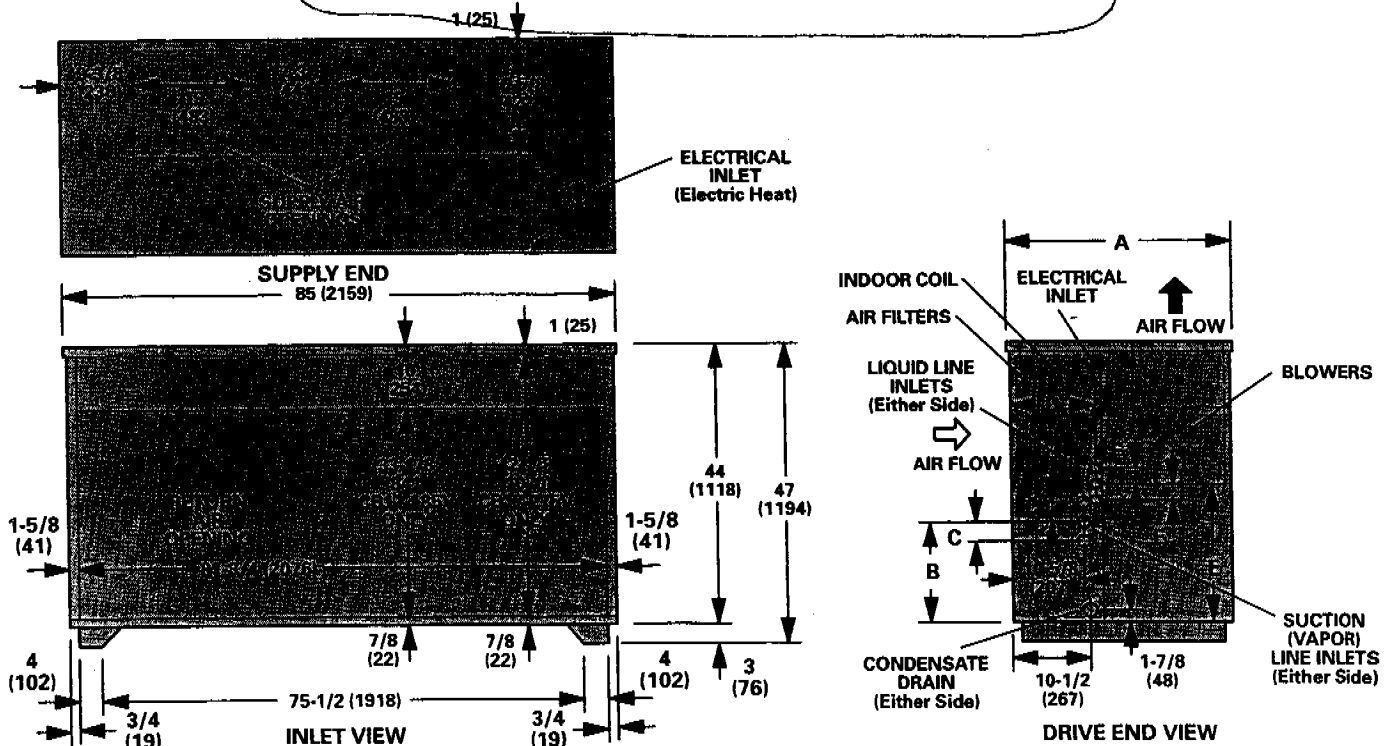

Model No.	A		B		C		D		E		F	
	in.	mm	in.	mm	in.	mm	in.	mm	in.	mm	in.	mm
CB17-185V	35	889	18-3/8	467	2-1/2	57	12-1/2	318	22-5/8	575	1-1/4	32
CB17-275V	44	1118	22-3/4	578	2-5/8	67	14-1/4	362	22-1/2	572	4-7/8	124