

CITY OF SACRAMENTO
1231 I Street, Sacramento, CA 95814

Permit No: 0013007
Insp Area: 4

Site Address: 2130 BLACKRIDGE AV SAC
Parcel No: 225-1400-005 NORTHPT PK 8 LOT 5

Sub-Type: NSFR
Housing (Y/N): N

CONTRACTOR

MOURIER JOHN CONSTRUCTION INC
1830 VERNON ST
SUITE 9 95687

OWNER

ARCHITECT

Nature of Work: NSFR MP2447 2 STORY 11 RMS

CONSTRUCTION LENDING AGENCY: I hereby affirm under penalty of perjury that there is a construction lending agency for the performance of the work for which this permit is issued (Sec. 3097, Civ. C).

Lender's Name _____ Lender's Address _____

LICENSED CONTRACTORS DECLARATION: I hereby affirm under penalty of perjury that I am licensed under provisions of Chapter 9 (commencing with section 7000) of Division 3 of the Business and Professions Code and my license is in full force and effect.

License Class B License Number 225004 Date 11-1-00 Contractor Signature M. J. Mouri

OWNER-BUILDER DECLARATION: I hereby affirm under penalty of perjury that I am exempt from the contractors License Law for the following reason (Sec. 7031.5, Business and Professions Code: any city or county which requires a permit to construct, alter, improve, demolish, or repair any structure, prior to its issuance, also requires the applicant for such permit to file a signed statement that he or she is licensed pursuant to the provisions of the Contractors License Law (Chapter 9 (commencing with Section 7000) of Division 3 of the Business and Professions Code) or that he or she is exempt therefrom and the basis for the alleged exemption. Any violation of Section 7031.5 by any applicant for a permit subjects the applicant to a civil penalty of not more than five hundred dollars (\$500.00).

____ I, as a owner of the property, or my employees with wages as their sole compensation, will do the work, and the structure is not intended or offered for sale (Sec. 7044, Business and Professional Code: The Contractors License Law does not apply to an owner of property who builds or improves thereon, and who does such work himself or herself or through his/her own employees, provided that such improvements are not intended or offered for sale. If, however, the building or improvement is sold within one year of completion, the owner-builder will have the burden of proving that he/she did not build or improve for the purpose of sale.)

____ I, as owner of the property, am exclusively contracting with licensed contractors to construct the project (Sec. 7044, Business and Professions Code. The Contractors License Law does not apply to an owner of property who builds or improves thereon, and who contracts for such projects with a contractor(s) licensed pursuant to the Contractors License Law).

____ I am exempt under Sec. _____ B & PC for this reason: _____

Date _____ Owner Signature _____

IN ISSUING THIS BUILDING PERMIT, the applicant represents, and the city relies on the representation of the applicant, that the applicant verified all measurements and locations shown on the application or accompanying drawings and that the improvement to be constructed does not violate any law or private agreement relating to permissible or prohibited locations for such improvements. This building permit does not authorize any illegal location of any improvement or the violation of any private agreement relating to location of improvements.

I certify that I have read this application and state that all information is correct. I agree to comply with all city and county ordinances and state laws relating to building construction and hereby authorize representative(s) of this city to enter-upon the abovementioned property for inspection purposes.

Date 11-1-00 Applicant/Agent Signature M. J. Mouri

WORKER'S COMPENSATION DECLARATION: I hereby affirm under penalty of perjury one of the following declarations:

____ I have and will maintain a certificate of consent to self-insure for workers' compensation as provided for by Section 3700 of the Labor Code, for the performance of work for which the permit is issued.

____ I have and will maintain workers' compensation insurance, as required by Section 3700 of the Labor Code, for the performance of the work for which this permit is issued. My workers' compensation insurance carrier and policy number are:

Carrier STATE COMPENSATION INS FUND Policy Number 156326600

____ (This section need not be completed if the permit is for \$100 or less) I certify that in the performance of the work for which this permit is issued, I shall not employ any person in any manner so as to become subject to the workers' compensation laws of California and agree that if I should become subject to the workers' compensation provisions of Section 3700 of the Labor Code, I shall forthwith comply with those provisions.

Date 11-1-00 Applicant Signature M. J. Mouri

WARNING: FAILURE TO SECURE WORKER'S COMPENSATION COVERAGE IS UNLAWFUL AND SHALL SUBJECT AN EMPLOYER TO CRIMINAL PENALTIES AND CIVIL FINES UP TO ONE HUNDRED THOUSAND DOLLARS (\$100,000) IN ADDITION TO THE COST OF COMPENSATION, DAMAGES AS PROVIDED FOR IN SECTION 3706 OF THE LABOR CODE, INTEREST AND ATTORNEY'S FEE.

THIS PERMIT SHALL EXPIRE BY LIMITATION IF WORK IS NOT COMMENCED WITHIN 180 DAYS.

CITY OF SACRAMENTO
NEIGHBORHOOD PLANNING
AND DEVELOPMENT SERVICES

RESIDENTIAL BUILDING PERMIT APPLICATION

New Construction Addition Remodels Other

Project Address: 2130 Blackridge Ave Assessor Parcel # 225-1400-005

OWNER INFORMATION:

Lot # 5

Legal Property Owner: John MOURIER Construction Phone # (916) 969-2842
 Owner Address: 1830 VERNON STREET, #9 City Roseville State Ca. Zip 95678

CONTRACTOR INFORMATION: Northpointe Park Unit #8 Village #1

Contractor: J.M.C. Lic. # 613004 Phone # 969-2842 Fax# 782-8903

PROJECT INFORMATION:

Land Use Zone R14 Occupancy Group R3 Construction Type VN Fed Code 14
 No. of stories: 2 No. of rooms: 11 Street width: _____
 1st Floor Area 1244 2nd Floor Area 1203 Basement _____ Roof Material _____

AREA IN SQUARE FOOT OF:	EXISTING	NEW
Dwelling/Living	_____	<u>2447</u>
Garage/Storage	_____	<u>565</u>
Decks/Balconies	_____	<u>127</u>
Carports	_____	_____

SCOPE OF WORK: _____

FOR OFFICE USE ONLY

- | | | |
|---|---|---|
| <input type="checkbox"/> Information above complete | <input type="checkbox"/> AR Flood Waiver required | <input type="checkbox"/> Planning Approval |
| <input type="checkbox"/> Violation files checked | <input type="checkbox"/> Flood Elevation Certificate Required | <input type="checkbox"/> Design Review Approval |
| <input type="checkbox"/> Standard setbacks | <input type="checkbox"/> Water Development Infill Area | <input type="checkbox"/> Special Fee Districts Apply: _____ |
| <input type="checkbox"/> County Sewer | | |

NEW STRUCTURES & ADDITIONS

❖ THE FOLLOWING MUST BE PROVIDED IN ORDER TO SUBMIT FOR PLAN REVIEW

- | | |
|---|---|
| <input type="checkbox"/> 2 COMPLETE PLANS, LEGIBLE & DRAWN TO SCALE | ❖ Plans to include: site plan, floor plan, elevations, roof/ceiling plan, foundation and structural framing details, and structural calculations for non-conforming structures. |
| <input type="checkbox"/> 3 SETS IF PROJECT IS IN A DESIGN REVIEW AREA | |
| <input type="checkbox"/> Title 24 Energy Compliance documentation | <input type="checkbox"/> 11" x 17" copy of floor plan for County Assessor |
| <input type="checkbox"/> Grading and Erosion Control Questionnaire | <input type="checkbox"/> Plan Review Fees |

Date: _____

Received by: (staff) _____

ACTIVITY/PERMIT # _____

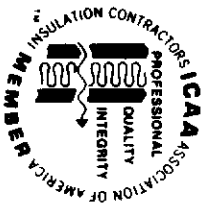

INSULATION CONTRACTORS ASSOCIATION OF AMERICA

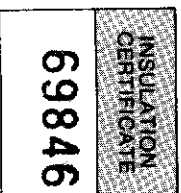

1321 DUKE STREET, SUITE 303 • ALEXANDRIA, VA 22314 • (703) 739-0356

THIS IS TO CERTIFY THAT INSULATION HAS BEEN INSTALLED IN CONFORMANCE WITH CURRENT ENERGY REGULATIONS, CALIFORNIA ADMINISTRATIVE CODE TITLE 24, STATE OF CALIFORNIA, IN THE BUILDING LOCATED AT

John Mueller LOT # 5 TRACT # MORTGAGES PARK

STREET 2130 Blackridge Rd CITY SHERMANTON

EXTERIOR WALLS:

MANUFACTURER _____ THICKNESS/TYPE _____ VALUE _____ R-

CEILINGS:

BATTS: MANUFACTURER _____ THICKNESS/TYPE _____ VALUE _____ R-
BLOWN IN: MINIMUM

MANUFACTURER _____ THICKNESS _____ VALUE 30 R-

SQUARE FOOTAGE COVERED 1493 NUMBER OF BAGS USED 27

FLOORS: MANUFACTURER _____ THICKNESS/TYPE _____ VALUE _____ R-

SLAB ON GRADE: MANUFACTURER _____ THICKNESS/TYPE _____ VALUE _____ R-

WIDTH OF INSULATION _____ INCHES

FOUNDATION WALLS: MANUFACTURER _____ THICKNESS/TYPE _____ VALUE _____ R-

GENERAL CONTRACTOR _____ DATE _____

CALIFORNIA CONTRACTORS LICENSE # _____ DATE _____

SIGNATURE _____ TITLE _____

INSULATION CONTRACTOR **ARCADE INSULATION** _____ DATE 9-21-01

CALIFORNIA CONTRACTORS LICENSE #268784 _____

SIGNATURE _____ TITLE _____



NORTHPOINTE 8-1

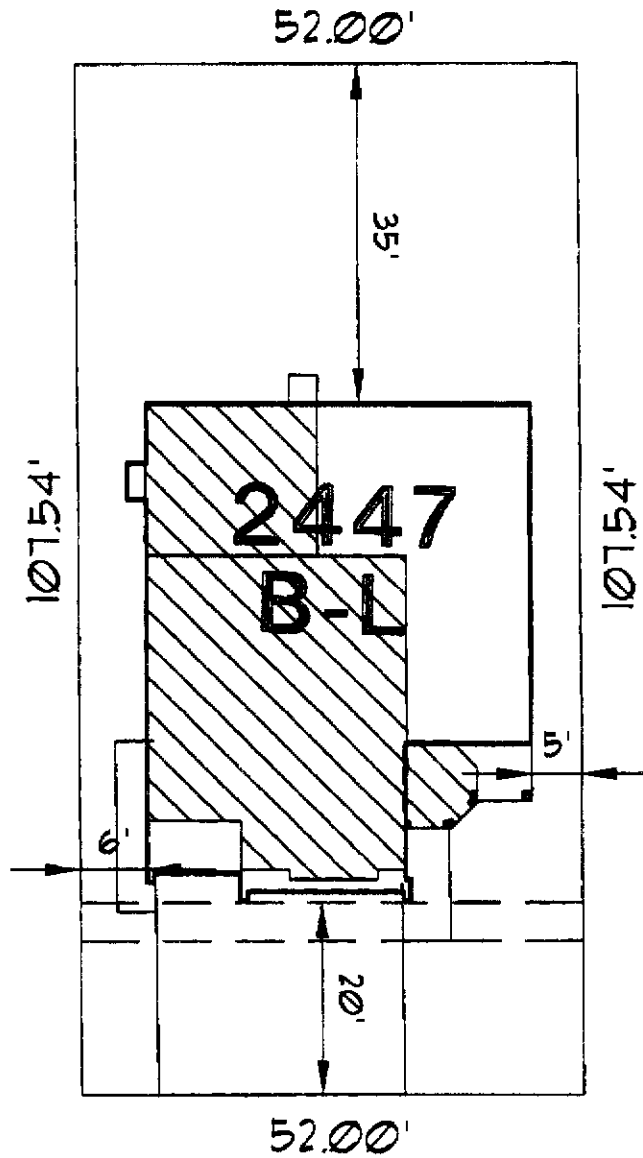

BLACKRIDGE AVE.

LOT: 5 SITE ADDRESS: 2130 BLACKRIDGE AVE.

WHEN USED FOR SALES OR CONTRACT PURPOSES THIS DOCUMENT DOES NOT GUARANTEE ANY DIMENSIONS, DISTANCES, BEARINGS OR SETBACKS. JMC RESERVES THE RIGHT TO MAKE CHANGES AT ANY TIME WITHOUT PRIOR NOTICE AND IS NOT RESPONSIBLE FOR IRREGULARITIES OR DIFFERENCES IN ACTUAL OR "AS-BUILT" LOT CHARACTERISTICS.

SCALE: 1"=20'

LOT SIZE: 5590 +/-

NP81-P05 DH 101600

COVERAGE: 31%

APN: 225-0140-005

1830 VERNON ST. No.8
ROSEVILLE, CA 95678
916-782-8979
CA. LIC. 913004

