



21

**CITY OF SACRAMENTO**

**DEPARTMENT OF PUBLIC WORKS**

ENGINEERING DIVISION

THOMAS M. FINLEY  
Engineering Division Manager

December 26, 1985

**APPROVED**  
BY THE CITY COUNCIL

CITY MANAGER'S OFFICE  
**RECEIVED**  
DEC 31 1985

City Council  
Sacramento, California

JAN 7 1985

OFFICE OF THE  
CITY CLERK

Honorable Members In Session:

SUBJECT: Revocable Encroachment Permit - 1030 J Street

SUMMARY

11th and J Associates/Bayside Capitol Company has applied for a Revocable Encroachment Permit for the purpose of installing an over the walk entry canopy.

The Director of Public Works recommends that the Permit be granted.

BACKGROUND

This request consists of an area 12 feet wide and 14 feet long, approximately 60 feet south of J Street over the 11th Street sidewalk.

RECOMMENDATION

The Director of Public Works recommends that the attached resolution be passed granting a Revocable Encroachment Permit to 11th and J Associates/Bayside Capitol Company in the area and for the purpose outlined above.

Respectfully submitted,

THOMAS M. FINLEY  
Engineering Division Manager

Recommendation Approved:

for: WALTER J. SLIPE  
City Manager

Approved:

for: MELVIN H. JOHNSON  
Director of Public Works

LJ:vr  
LJ107Ck3

Attachment

January 7, 1986  
District No. 1

1950

1951

1952

1953

1954

1955

1956

1957

1958

1959

1960

1961

1962

1963

1964

1965

1966

1967

**RESOLUTION NO. 86-002**

Adopted by The Sacramento City Council on date of

**RESOLUTION GRANTING REVOCABLE ENCROACHMENT PERMIT TO:**

**11th and J Associates/Bayside Capitol Company**

**BE IT RESOLVED BY THE COUNCIL OF THE CITY OF SACRAMENTO:**

That a Revocable Encroachment Permit for the purpose of installing an over the walk entry canopy is hereby granted to 11th and J Associates/Bayside Capitol Company, whose address is as follows 1035 East Hillsdale Boulevard #225, Foster City, CA 94404.

**This encroachment is described as follows:**

A canvas covered steel frame canopy with business logo 12 feet wide, 14 feet long, eight feet above the 11th Street sidewalk supported by two inch brass legs approximately ten feet from the building.

This permit is granted subject to the "General Provisions - Revocable Encroachment Permit", which were adopted by the City Council in Resolution No. 81-845 dated November 17, 1981, and the hereinafter specified special conditions, if any. This permit shall be effective only after the applicant files with the Risk Management and Insurance Division of the City of Sacramento, the insurance certificates required by the General Provisions.

**SPECIAL CONDITIONS**

Structural design of the canopy must be approved by the Building Inspector and all covering material shall be approved by the Fire Marshal.

**APPROVED**  
BY THE CITY COUNCIL

**JAN 7 1985**

**OFFICE OF THE  
CITY CLERK**

\_\_\_\_\_  
MAYOR

ATTEST:

\_\_\_\_\_  
CITY CLERK

THE UNIVERSITY OF CHICAGO  
DEPARTMENT OF POLITICAL SCIENCE

PH.D. THESIS

THE UNIVERSITY OF CHICAGO  
DEPARTMENT OF POLITICAL SCIENCE  
PH.D. THESIS

THE UNIVERSITY OF CHICAGO  
DEPARTMENT OF POLITICAL SCIENCE  
PH.D. THESIS

THE UNIVERSITY OF CHICAGO  
DEPARTMENT OF POLITICAL SCIENCE  
PH.D. THESIS

THE UNIVERSITY OF CHICAGO  
DEPARTMENT OF POLITICAL SCIENCE  
PH.D. THESIS

THE UNIVERSITY OF CHICAGO  
DEPARTMENT OF POLITICAL SCIENCE  
PH.D. THESIS

THE UNIVERSITY OF CHICAGO  
DEPARTMENT OF POLITICAL SCIENCE  
PH.D. THESIS

THE UNIVERSITY OF CHICAGO  
DEPARTMENT OF POLITICAL SCIENCE  
PH.D. THESIS

THE UNIVERSITY OF CHICAGO

THE UNIVERSITY OF CHICAGO  
DEPARTMENT OF POLITICAL SCIENCE  
PH.D. THESIS

THE UNIVERSITY OF CHICAGO  
DEPARTMENT OF POLITICAL SCIENCE  
PH.D. THESIS

THE UNIVERSITY OF CHICAGO

THE UNIVERSITY OF CHICAGO

AWNING AND CANOPY LAYOUT

BAYSIDE CAPITAL - PENNISI'S

SIDE VIEW

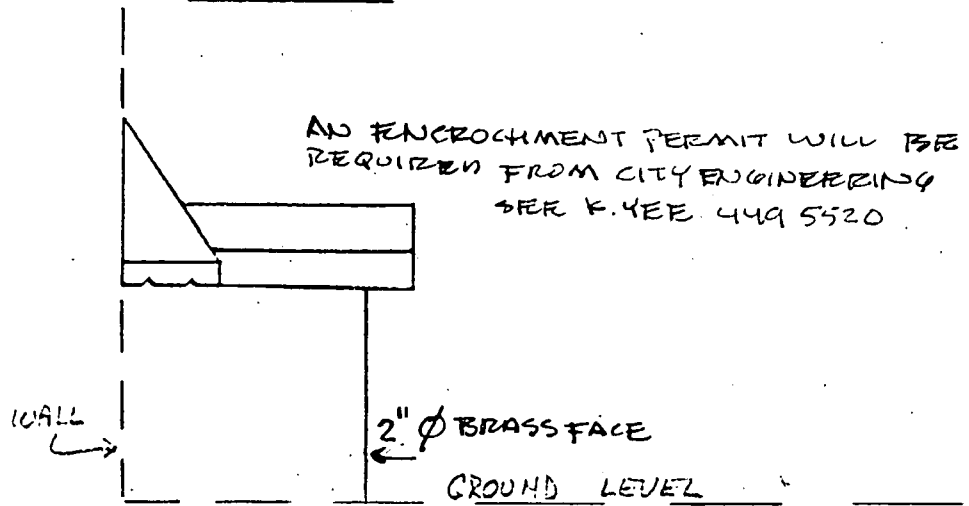

LOCATION

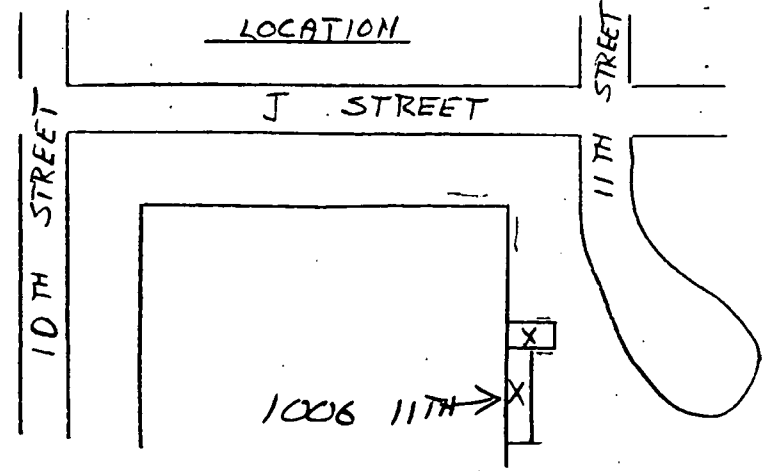

FRONT VIEW

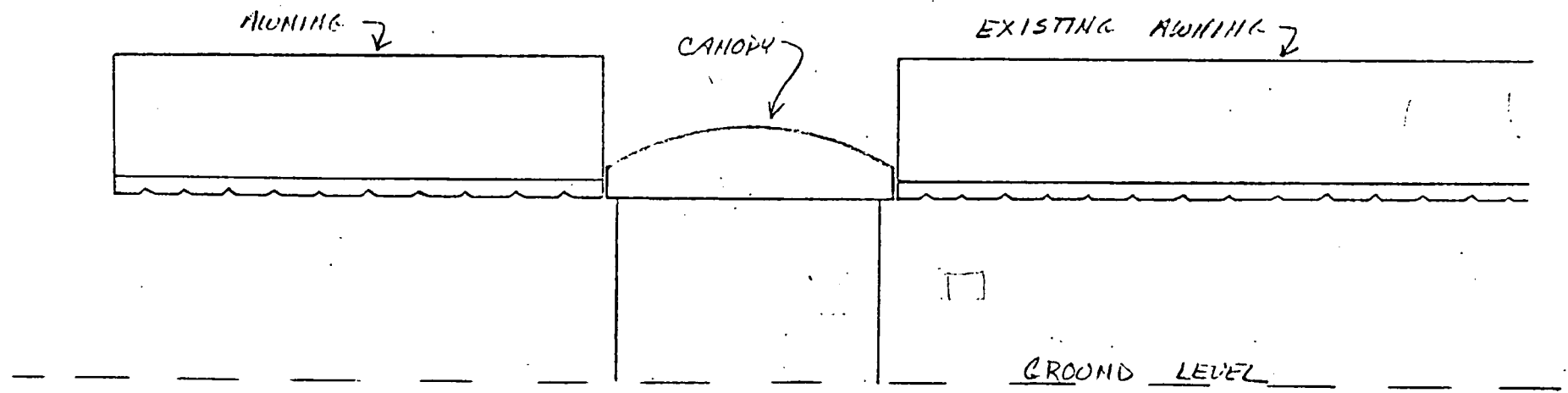

DESIGN & SIGN APPROVED AS NOTED  
10.9.85 T. HASTINGS

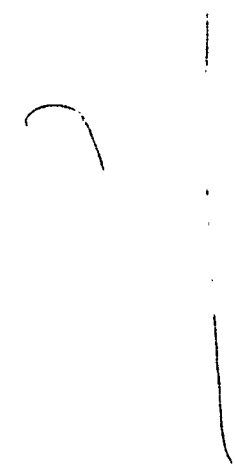
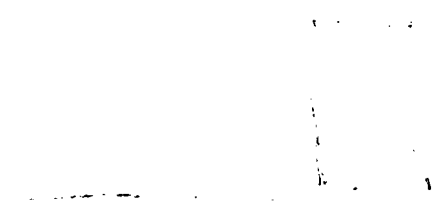
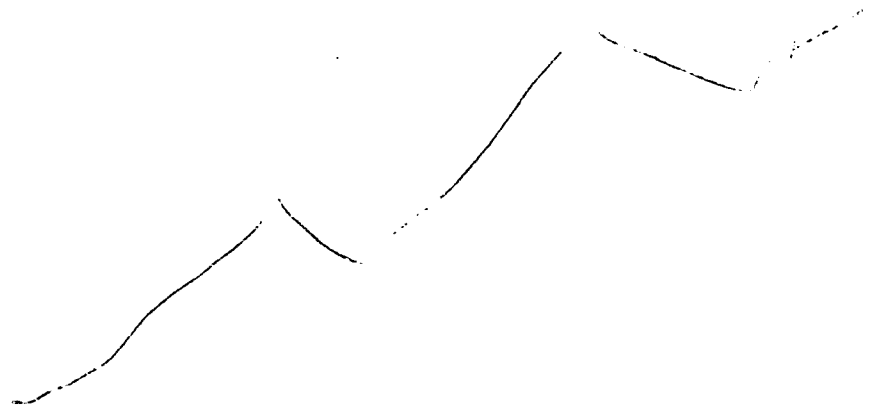

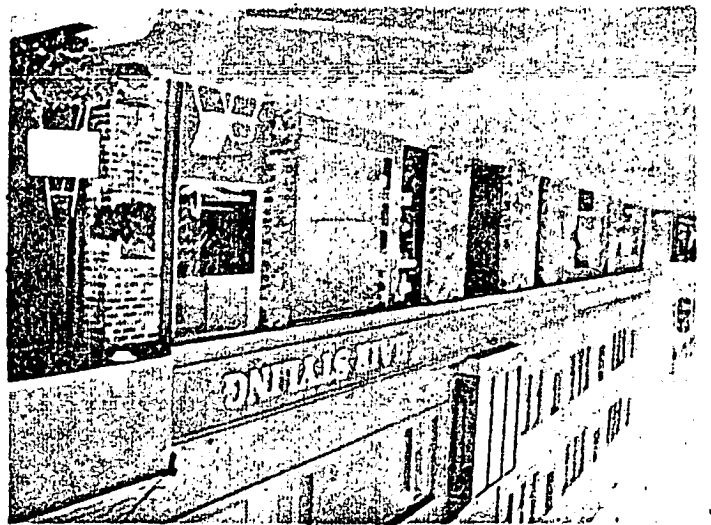
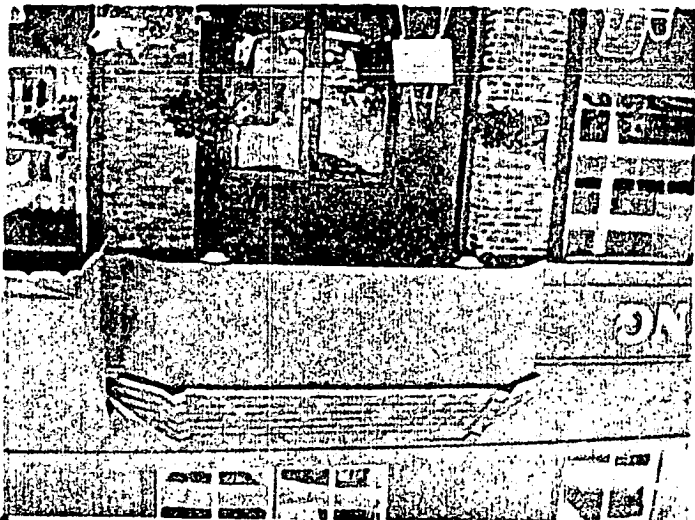
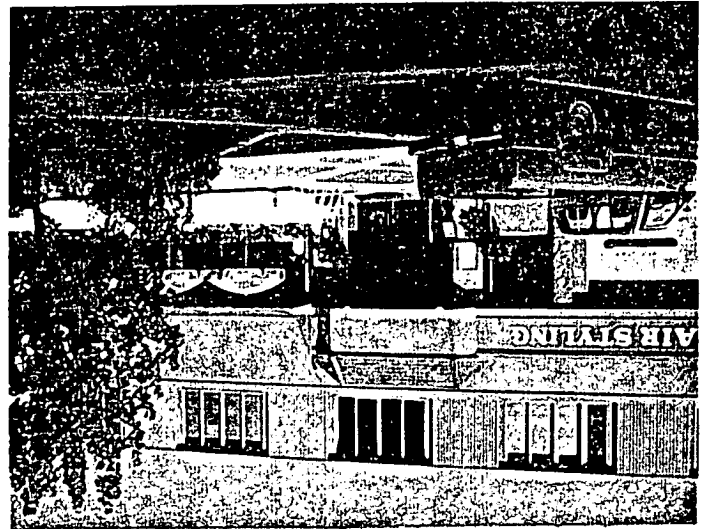
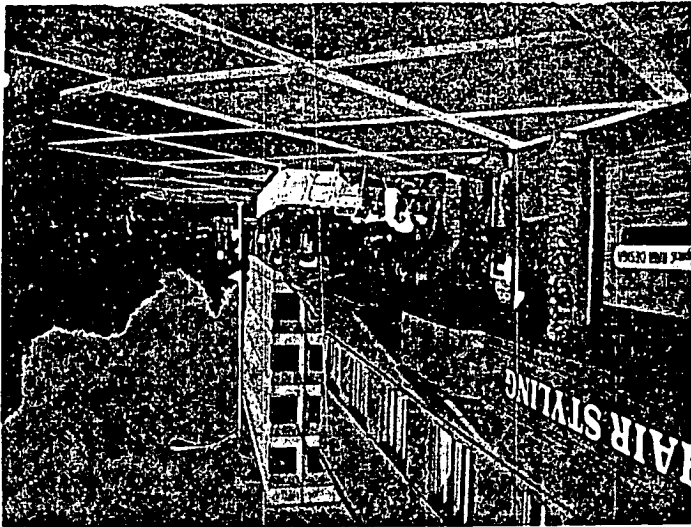

OVER-THE-DOOR CURVED LEAF CANOPY

PERMITS 0 011

FRONT VIEW

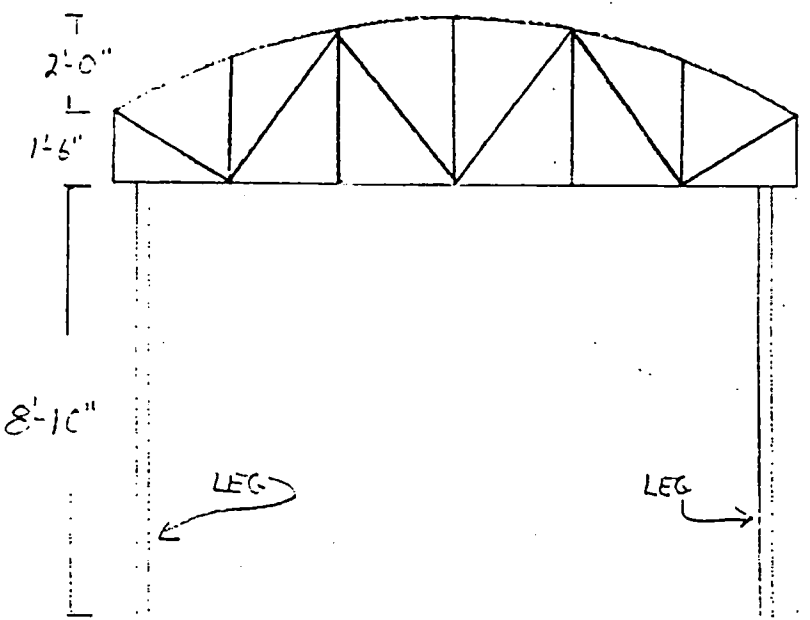

SIDE VIEW

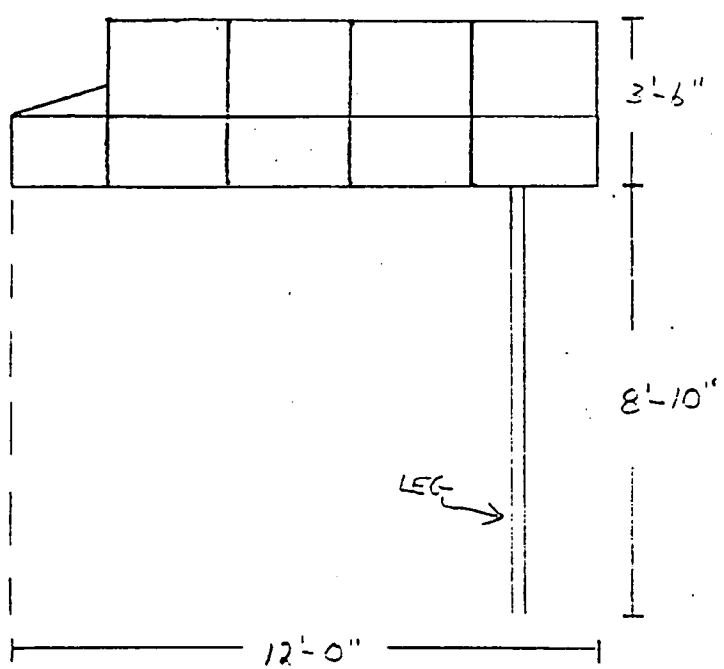

TOP VIEW

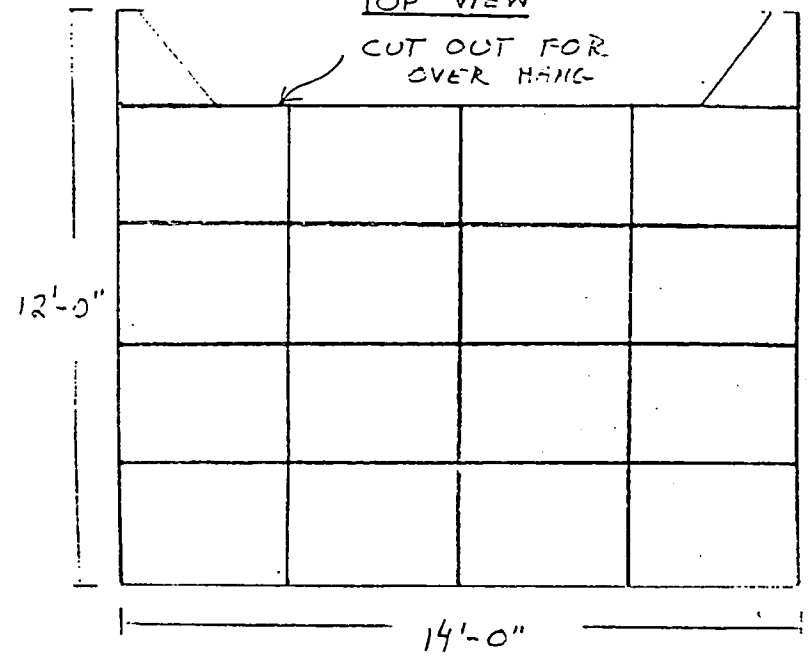

SPECIFICATIONS

- FABRIC - DARK GREEN FLAME-RETARDANT PYROTONE 2
- FRAME - ONE-PIECE WIELDED FRAME OF 1" GALVANIZED STEEL TUBING (16 GA.)

ATTACHMENT

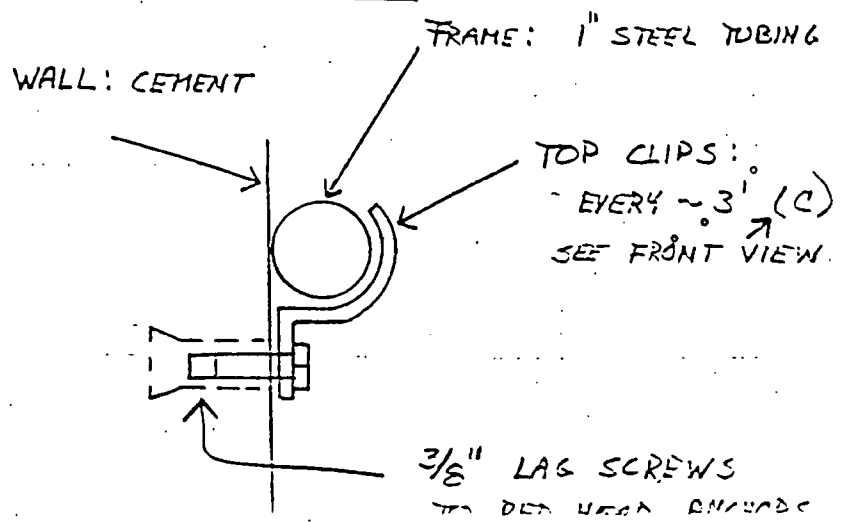



FRONT VIEW

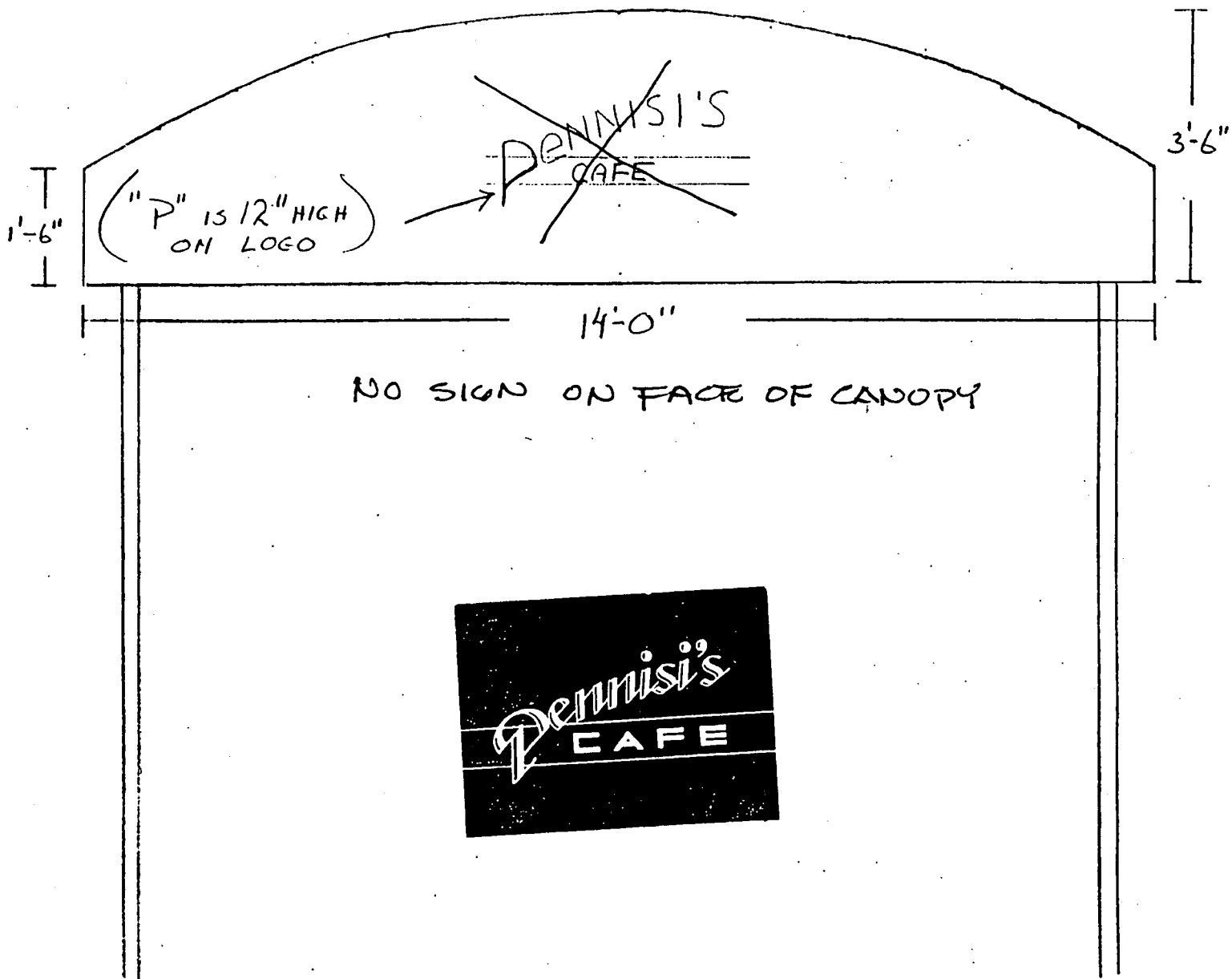

11th & J Street  
Sacramento, CA 95814  
446-6988 & 89

SIDE VIEW

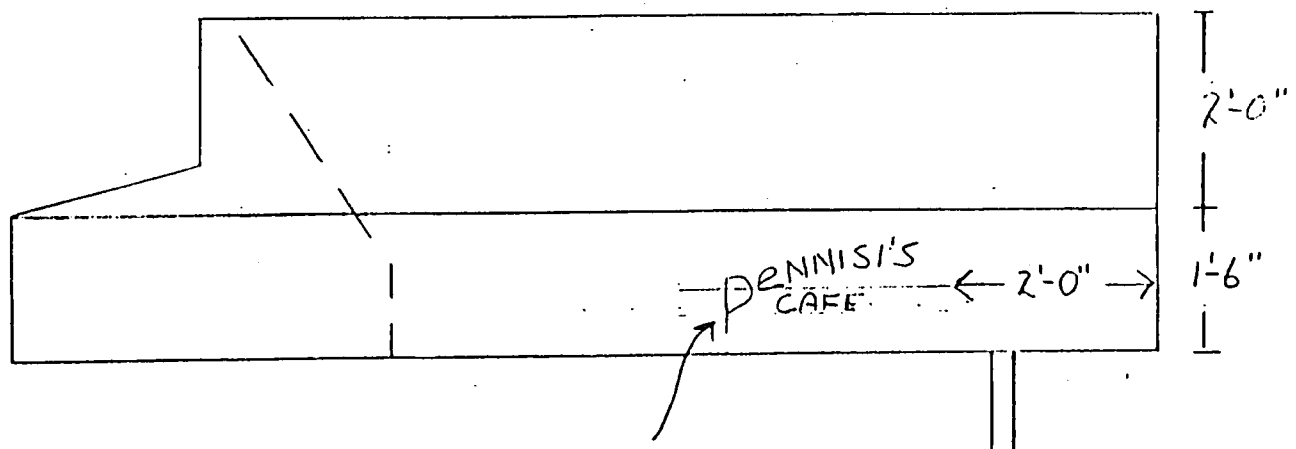

"P" IS 7" HIGH  
ON LOGO

SIGN ON EACH SIDE OF CANOPY O.K.



11th & J Street  
Sacramento, CA 95814  
446-6988 & 89

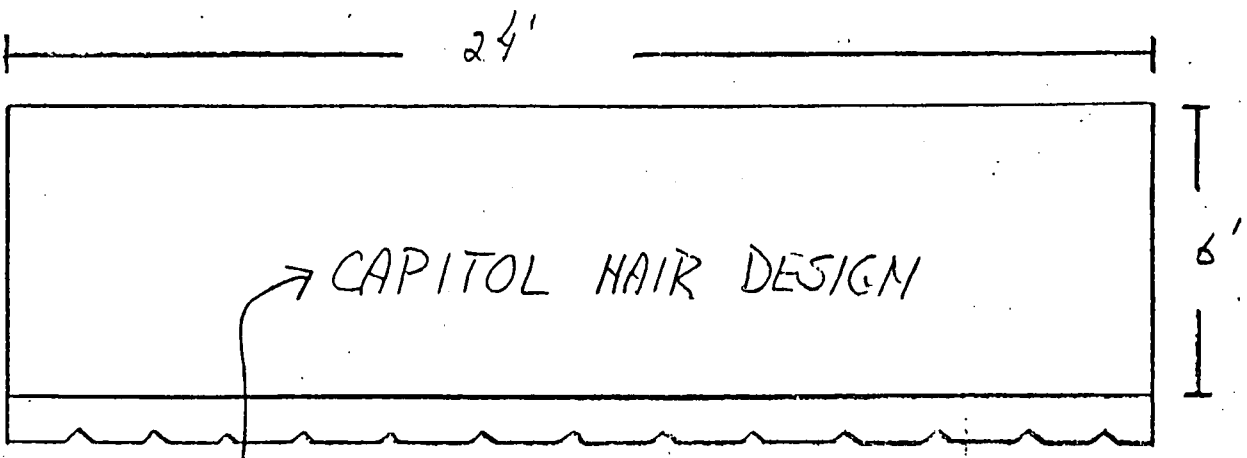

1'-0" HIGH LETTERS  
LETTER COLOR: WHITE

SIGN TO MATCH  
WINDOW SIGN



City Clerk - City Hall.

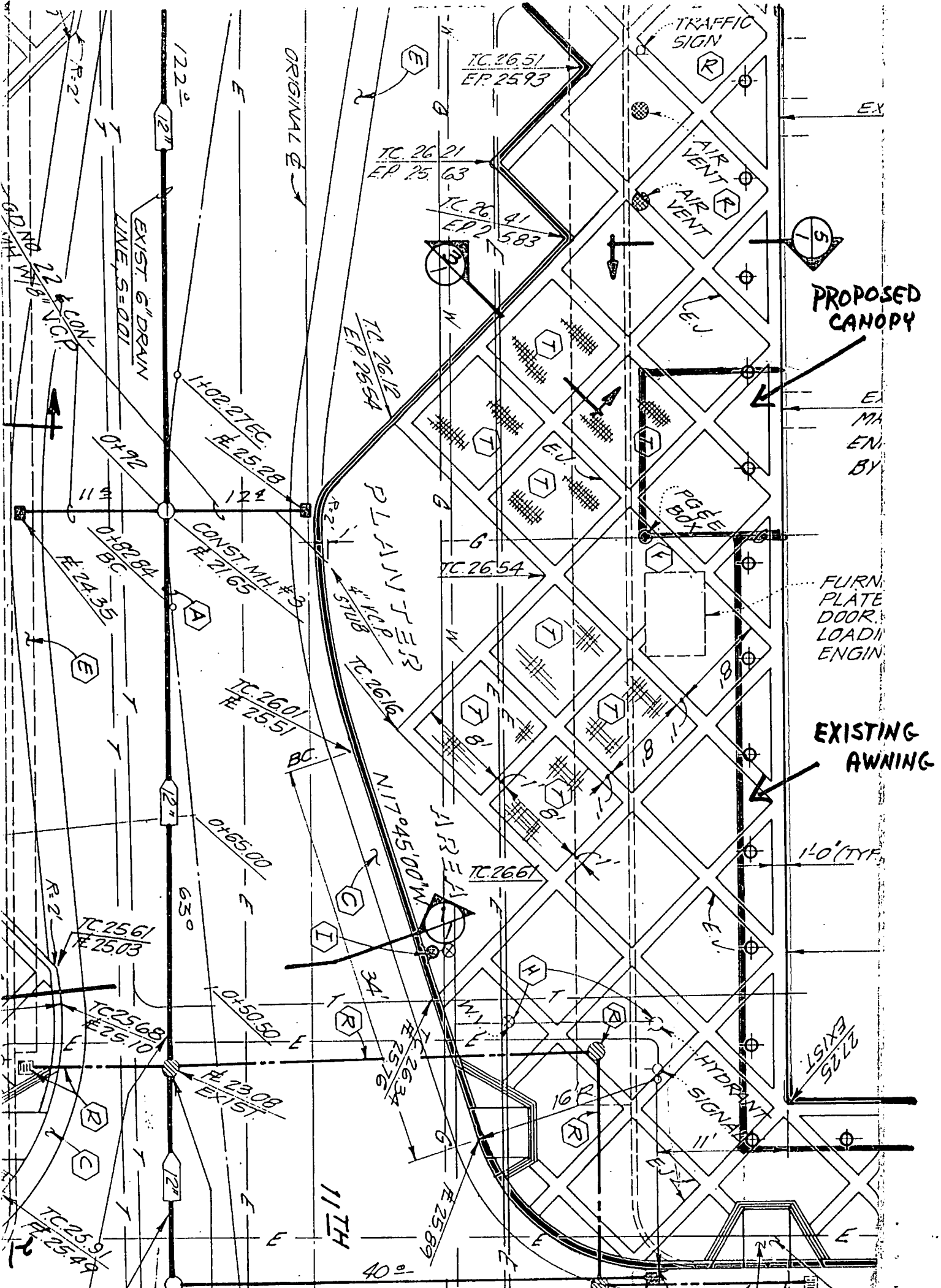

PROPOSED CANOPY

EXISTING AWNING

FURN. PLATE DOOR. LOADING ENGINE

27'25" EXIST

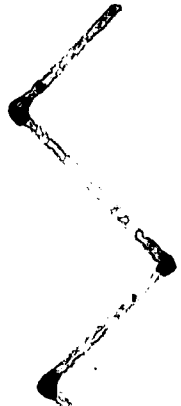

# UNITEX

PRESENTS "TIME TESTED"

# PYROTONE 2 Flame Retardant

50% POLYESTER/50% COTTON

Available in 31/32" and New 60/61" Width

### USES:

Tents • Awnings • Canopies • Carnival Booths  
Athletic Equipment • Banners • Covers

This new fabric has a superior strength to weight ratio.  
PYROTONE 2 has a soil resistant finish, a super water  
repellancy and has an extra HEAVY mildew resistant finish.



653 Red

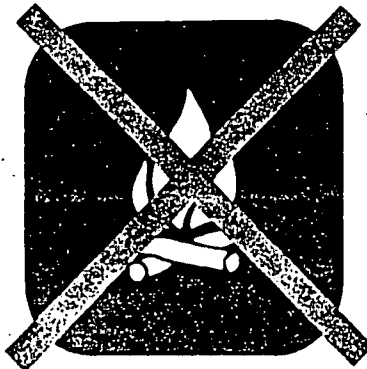

State Fire Marshal's Seal for Registered Flame Retardant PYROTONE 2 has the California state fire marshal approval (no. F177.2) and passes CPAI-84FR.

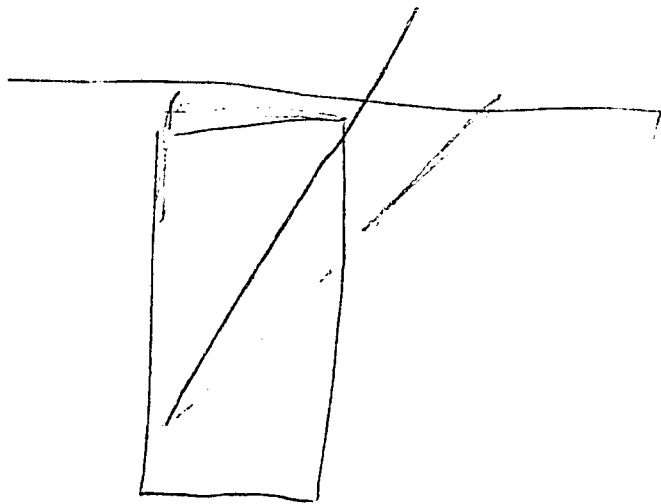



January 17, 1986

llth and J Associates  
Bayside Capitol Company  
1035 East Hillside Blvd. #225  
Foster City, CA 94404

Dear Gentlemen:

On January 7, 1986, the Sacramento City Council adopted a resolution granting the following Revocable Encroachment Permit in accordance with "General Provisions - Revocable Encroachment Permit," adopted by Council Resolution 81-845 as amended.

The permit is for the purpose of installing an over the walk entry canopy located at 1030 J Street.

This permit shall be effective only after you file with the Risk Management and Insurance Division of the City of Sacramento, **5730 24th Street, Bldg. 3A, Sacramento, CA 95822**, the insurance certificates required by the General Provisions.

Enclosed, for your records, is a copy of the resolution granting the permit, and Council Resolution 81-845, as amended.

Sincerely,

Lorraine Magana  
City Clerk

LM/dbp/2.1

Enclosures (2)

cc: Risk Management

1. The first part of the document discusses the importance of maintaining accurate records of all transactions.

2. It also highlights the need for regular audits to ensure compliance with financial regulations.